

Liquid Air Energy Storage with LNG cold recovery for air liquefaction improvement

Peng, Xiaodong; She, Xiaohui; Nie, Binjian; Li, Chuan; Li, Yongliang; Ding, Yulong

DOI:

[10.1016/j.egypro.2019.01.724](https://doi.org/10.1016/j.egypro.2019.01.724)

License:

Creative Commons: Attribution-NonCommercial-NoDerivs (CC BY-NC-ND)

Document Version

Publisher's PDF, also known as Version of record

Citation for published version (Harvard):

Peng, X, She, X, Nie, B, Li, C, Li, Y & Ding, Y 2019, 'Liquid Air Energy Storage with LNG cold recovery for air liquefaction improvement', *Energy Procedia*, vol. 158, pp. 4759-4764.
<https://doi.org/10.1016/j.egypro.2019.01.724>

[Link to publication on Research at Birmingham portal](#)

Publisher Rights Statement:

Checked for eligibility: 23/05/2019

General rights

Unless a licence is specified above, all rights (including copyright and moral rights) in this document are retained by the authors and/or the copyright holders. The express permission of the copyright holder must be obtained for any use of this material other than for purposes permitted by law.

- Users may freely distribute the URL that is used to identify this publication.
- Users may download and/or print one copy of the publication from the University of Birmingham research portal for the purpose of private study or non-commercial research.
- User may use extracts from the document in line with the concept of 'fair dealing' under the Copyright, Designs and Patents Act 1988 (?)
- Users may not further distribute the material nor use it for the purposes of commercial gain.

Where a licence is displayed above, please note the terms and conditions of the licence govern your use of this document.

When citing, please reference the published version.

Take down policy

While the University of Birmingham exercises care and attention in making items available there are rare occasions when an item has been uploaded in error or has been deemed to be commercially or otherwise sensitive.

If you believe that this is the case for this document, please contact UBIRA@lists.bham.ac.uk providing details and we will remove access to the work immediately and investigate.



10th International Conference on Applied Energy (ICAE2018), 22-25 August 2018, Hong Kong, China

Liquid Air Energy Storage with LNG cold recovery for air liquefaction improvement

Xiaodong Peng^a, Xiaohui She^a, Binjian Nie^a, Chuan Li^a, Yongliang Li^a, Yulong Ding^{a,*}

^a*Birmingham Center for Energy Storage, School of Chemical Engineering, University of Birmingham*

Abstract

The rapid increase in application of intermittent renewable energy generation has stimulated the development of energy storage system to guarantee a stable supply in electricity grid. As a large-scale storage technology, Liquid Air Energy Storage (LAES) technology has attracted many attractions in recent years due to it offers many unique advantages including high energy density, mature technologies based and geographical-constraint free. However, current LAES has relatively low round trip efficiency (less than 60%) and still needs improvement.

In the LAES, the recovered cold energy from the liquid air is insufficient to cool the compressed air to the lowest temperature with the shortage of ~18% and liquid air yield does not achieve the maximum in the charging process; external free cold sources would be needed to further increase the liquid air yield, and the round trip efficiency could easily break through 60%.

This paper proposes an innovative LAES system integrated with LNG regasification process, the objectives in this established work are to improve the product yield of liquid air and enhance the overall roundtrip efficiency. Sensibility analysis and exergy efficiency analysis of charging process and discharging process at LAES are discussed. Meanwhile, the comparisons of system performance are made between traditional LAES system and LAES with LNG regasification system (LAES-LNG) at same operating parameters. Through the LAES-LNG system, more liquid air is generated. Results show that relatively higher round trip efficiency could be obtained, with 15-35% enhancement compared with the current LAES. Also, liquid air yield obtains a significant improvement to 0.87.

© 2019 The Authors. Published by Elsevier Ltd.

This is an open access article under the CC BY-NC-ND license (<http://creativecommons.org/licenses/by-nc-nd/4.0/>)

Peer-review under responsibility of the scientific committee of ICAE2018 – The 10th International Conference on Applied Energy.

Keywords: energy storage; liquid air; LNG; refrigeration; renewable energy

* Corresponding author. Tel.: +44-121-414-5279.

E-mail address: Y.Ding@bham.ac.uk

1. Introduction

In the past decade, the widely use of intermittent renewable sources and growing requirement of low carbon emissions greatly promote the development of energy storage technologies in many developed and developing countries. The world power generation capacity from Renewable source has rapidly risen from 6% at 2007 to 27.7% at the end of 2014 [1]. Energy storage technologies is a promising way to solve unstable electricity supply caused by intermittent renewable sources. Besides, it contributes to achieve peak-load shifting in electricity grid to remit electricity waste due to the mismatch between power demand and power supply [2].

Among all innovative energy storage technologies, Liquid Air Energy Storage (LAES) gradually attracts many attentions because the LAES possesses many advantages such as a high energy storage density, geographical flexibility, mature technologies, and a relatively low capital cost [3]. LAES use intermittent renewable rouses or off-peak time power to produces liquid air and energy is stored in liquid phase, while stored energy is extracted from liquid air and drive turbines and generators to recover electricity at peak time when electricity energy is in high demand and expansive.

However, the development of LAES is gravely limited by its low roundtrip efficiency. Several researches have been studied to improve the roundtrip efficiency through system structure optimization or device performance optimization. For an independent LAES, roundtrip efficiency can be improved significantly through energy storage unit to recovery and reuse the compression heat from air compression and the cold energy from liquid air evaporation [4–8]. Morgan et al. [5,6] optimized air liquification process by adding a Claude cycle in cold box and an improved efficiency of 57% is achieved. Sciacovelli et al. [7] design an optimized direct-contact cold store using pebbles and rocks as cryogenic energy carriers to improve operation efficiency of cold recovery unit and described a dynamic model of cold store effecting the performance of LAES. Guizzi et al. [8] has studied a thermodynamic analysis of an independent LAES with energy recovery and ruse section and discussed system performance effected by different conditions such as isentropic efficiency of turbine, pressure losses and pinch-point temperature of heat exchanger, it is concluded that a 54–55% of roundtrip efficiency could be calculated. The other researchers claimed that the performance of LAES could be improved through LAES integrated with other industries [9,10]. Li et al. [9] presented a LAES integrated with nuclear power generation. It can achieve a highly efficient time shift of electrical power output and LAES can achieve a higher roundtrip efficiency of 70%. Antonelli et al. [10] presented a compression of hybrid LAES system with and without flue combustion. It was found that LAES with flue combustion can achieve a higher roundtrip efficiency of over 80%.

The previous research has found that the recovered cold energy from the liquid air is insufficient to cool the compressed air to the lowest temperature with the shortage of ~18% and liquid air yield does not achieve the maximum in the charging process [11]. This research efforts to find a high-quality cold source to improve liquid air yield as well as roundtrip efficiency. Natural Gas (NG) is has taken 21% of energy source for global energy demand by the end of 2015 [12] and its fast-growing owes to its advantages such as clean and high-efficient combustion, easy transportation and storage, higher energy density [13,14]. Liquefied Natural Gas (LNG) is cryogenic liquid form of natural gas by cooling natural gas to approximately 112 K at atmospheric pressure. Therefore, LNG regasification process brings opportunities to use LNG cryogenic energy to integrate with other industries for economy purposes, such as cryogenic energy electricity production, low temperature CO₂ capture, cold storage system and air separation process.

This research study proposes an innovative LAES system integrated with LNG regasification process, the objectives in this established work are to improve the product yield of liquid air and enhance the overall roundtrip efficiency. Sensibility analysis and exergy efficiency analysis of charging process and discharging process at LAES are discussed. Meanwhile, the comparisons of system performance are made between traditional LAES system and LAES with LNG regasification system (LAES-LNG) at same operating parameters.

2. Description of cycle

Fig. 1 shows the schematic diagram of the LAES-LNG system, which is composed of an air charging cycle, air discharging cycle, LNG cycle and a Brayton cycle. The air charging cycle is launched at off-peak time: purified air enters multistage compressors to increase the pressure, and meanwhile the compression heat is recovered by thermal

oil; then it enters the cold box and is cooled by the cold energy from LNG and liquid air; finally, the cold air expands in the cryo-expander, and part of air becomes liquid which is stored in the liquid air tank.

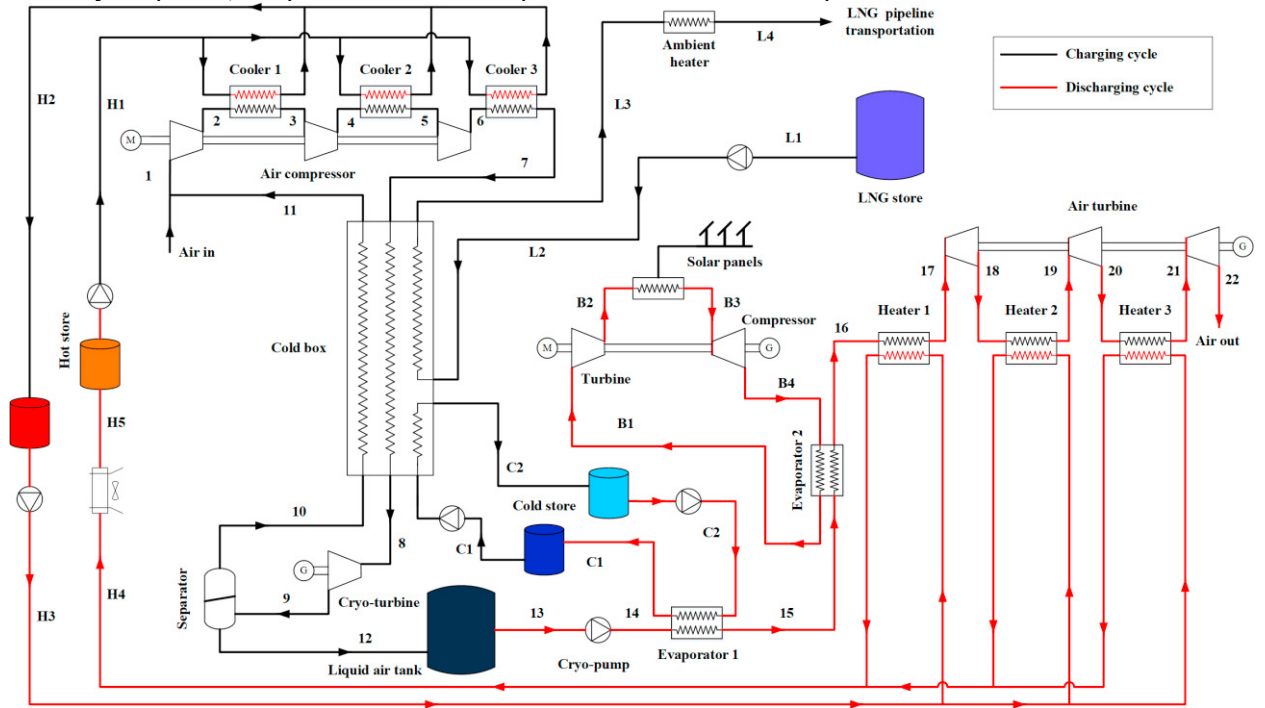

Fig. 1 Schematic diagram of the LAES-LNG system.

The LNG cycle works at off-peak time together with the air charging cycle: LNG is pumped to a high pressure; then it releases cold energy to the compressed air in the air charging cycle. The air discharging cycle is launched at peak time: liquid air flows out of the liquid air tank and is pumped over its critical pressure; pumped air releases part of cold energy to propane which is stored and reused in the air charging cycle, and the rest cold energy is used to drive a Brayton cycle using nitrogen (N₂) as working medium; before entering each stage of turbines to generate electricity, the air is superheated to a higher temperature by stored thermal oil to enlarge its work capacity.

3. System evaluation and simulation

3.1. Performance indexes

In LAES and LAES-ARC-ORC system, the roundtrip efficiency can be described as follow:

$$\eta_{RTE,LAES} = \frac{W_{out}}{W_{in}} = \frac{m_d w_d}{m_c w_c} \tag{1}$$

$$\eta_{RTE,LAES-LNG} = \frac{W_{out}}{W_{in}} = \frac{m_{13} w_d + m_{B1} w_B}{m_1 w_c} \tag{2}$$

The exergy efficiency of the charging cycle and that of the discharging cycle can be respectively defined as:

$$\eta_{ex,c} = \frac{E_{out,c}}{E_{in,c}} = \frac{m_{12} e_{12} + m_{H1} (e_{H2} - e_{H1}) + m_8 w_E}{m_1 w_c + m_{L1} (e_{L2} - e_{L3}) + m_{C1} (e_{C1} - e_{C2})} \tag{3}$$

$$\eta_{ex,d} = \frac{E_{out,d}}{E_{in,d}} = \frac{m_{13} w_T + m_{C1} (e_{C1} - e_{C2}) + m_{B1} w_B}{m_{13} e_{13} + m_{H3} (e_{H3} - e_{H5}) + m_{13} w_P} \tag{4}$$

3.2. Assumptions and parameters

In this study, the transport pressure of natural gas is set to 7 MPa to satisfy the requirements of long-distance distribution. The major chemical component of natural gas (NG) and LNG is methane, which occupies 87.0% to 99.8% of the total [15]. Therefore, methane is regarded as LNG and NG during simulation. In the LAES, the air is pretreated (CO₂ and water removal) and consists of nitrogen (78.12%), oxygen (20.96%) and argon (0.92%) while pressured nitrogen is considered as the mainly working medium in the Brayton cycle. The calculation for the LAES-LNG system is implemented by MATLAB; the thermal properties of air, propane, nitrogen and methane are evaluated by REFPROP 8.1, while thermal properties of thermal oil come from ASPEN plus. The other parameters are illustrated in Table 1.

4. Results and discussions

4.1. Performance of LAES and LAES-LNG

For a proposed net output power of 10 MW system, LAES-LNG and LAES consume the same quantity of liquid air to generate electricity as Table 2 shown, but LAES-LNG consumes about 19.6% fewer electric energy than traditional LAES during the air liquification process, thus, the roundtrip efficiency has been greatly improved from 53.09% to 76.05%. The significant drop of exergy efficiency for LAES-LNG discharging cycle is because that some recovered cold energy drives a Brayton cycle whose performance is limited by its relatively lower thermal efficiency of approximately 50% with low-temperature heat source.

Table 2 performance results of the LAES and LAES-LNG.

Items	LAES-LNG		LAES	
	Charging	Discharging	Charging	Discharging
Net power (MW)	13.15	10.00	18.84	10.00
Air mass flow rate (kg/s)	23.17	20.14	28.82	20.14
Exergy efficiency	86.14%	69.92%	78.78%	80.67%
LNG mass flow rate (kg/s)	11.28		-	
Liquid air yield	0.8693		0.6989	
Round trip efficiency	76.05%		53.09%	

4.2. Influence of LNG injection on LAES-LNG performance

Fig. 2 illustrates how much mass flow of LNG input affects LAES-LNG system, in terms of liquid air yield, roundtrip efficiency, exergy efficiency for energy storage section and supplied air temperature at cold box outlet. The X-coordinate represents the mass flow rate between LNG and supplied air through liquification. The increase in LNG mass flow leads to the increase in liquid air yield, roundtrip efficiency and exergy efficiency until maximum at same mass flow and any further increase brings no contributions or even slight drop in exergy efficiency. The drop is due to any further increase in LNG results in the increase of exergy input but with no change in exergy output. Conversely, the air temperature at cold end of cold box shows a sharply drop at first, followed by a slow-down drop till a minimum and stays the same with any further LNG injection. The remarkable trend changes at LNG mass flow rate less than approximately 0.19 appears due to LNG can be well heated and fully exchanges heat with supplied air,

Table 1. Default parameters of the LAES-LNG.

Parameter	Value
Ambient temperature	298 K
Ambient pressure	0.1 MPa
Pinch point in coolers	2.0 K
Pinch point in cold box	5.0 K
Pinch point in evaporators	2.0 K
LNG feed temperature	111.5 K
Pumped LNG pressure	7.0 MPa
Pressure drop	1%
Isentropic efficiency of compressor	85%
Isentropic efficiency of turbine	90%
Isentropic efficiency of pump	75%
Isentropic efficiency of cryogenic expander	75%
Turbine inlet pressure in Brayton cycle	3.5 MPa
Compressor inlet pressure in Brayton cycle	10.0 MPa

and its temperature at hot end of cold box can reach to near-ambient temperature. After LNG mass flow rate over 0.19, LNG temperature at hot end of cold box starts to drop, liquid air yield, roundtrip efficiency, exergy efficiency and supplied air temperature is changed at relatively slow rate until their own extremum, then LNG temperature drops significantly if further LNG is injected.

4.3. Influence of charging pressure on performance of LAES-LNG

Fig. 3 (a) illustrates how roundtrip efficiency and liquid air yield change with the increase in charging pressure (P_6) at the charging cycle of the LAES-LNG. The trends are carried out through applying a constant discharging pressure (P_{14}) and multigroup operating conditions are analyzed with discharging pressure of 8 MPa, 10 MPa and 12 MPa respectively. it is obvious that the optimal liquid air yield increases slightly with the increase in charging pressure (dashed lines). Additionally, with increase in charging pressure, the roundtrip efficiency of LAES-LNG shows a smooth drop, approximately 1% drop per 1 MPa growth. It can be explained that the output power of LAES-LNG system keeps almost unchanged due to there is no notable change in liquid air yield and the consumption of compressor presents a significant increase with the increase in charging pressure. These two main reasons would lead to the roundtrip efficiency drop.

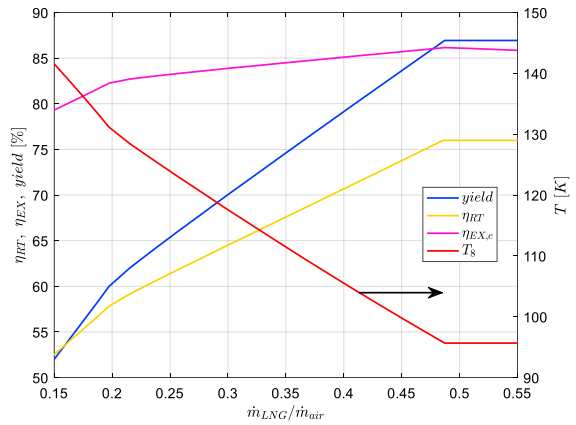

Fig. 2 Influence of LNG injected to cold box on liquid air yield, roundtrip efficiency, exergy efficiency for energy storage section and supplied air temperature at cold box outlet.

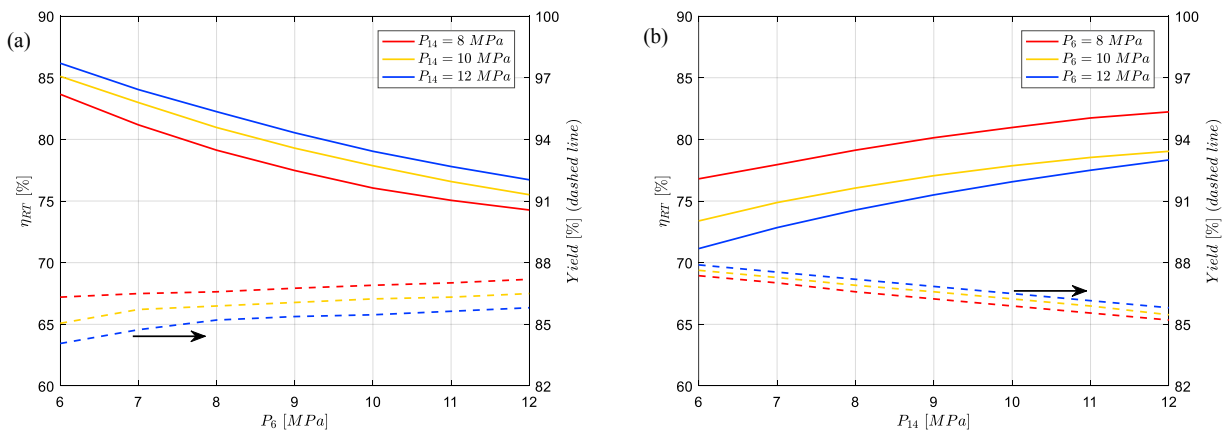

Fig. 3 Influence of pressure changes on the performance of the LAES-LNG system; (a) charging pressure (b) discharging pressure.

Fig. 3 (b) illustrates how roundtrip efficiency and liquid air yield change with the increase in discharging pressure P_{14} at energy storage section of LAES-LNG system. The increase in discharging pressure results in the increasing value of roundtrip efficiency, approximately 1% per 1 MPa growth. Higher pressure ratio contributes to larger net output of turbine and further leads to the increase in roundtrip efficiency. It should also be noticed that discharging pressure cannot directly act on liquid air yield, but the change in discharging pressure directly effects the temperature of propane, which heat exchanges with liquid air and recovers the cryogenic energy. It is possible to infer that the increase in liquid air pressure leads to an increase in its temperature, and further influences the temperature of cold energy storage material in cold store. When ignored the energy losses of cold store, the temperature of energy storage material will be able to affect the optimal temperature of high-pressure air due to the

energy storage material carries different grades of cold energy flowing into cold box. As the dashed lines show in Fig. 3 (b), the increase of discharging pressure results in a slight drop in liquid air yield, approximately 0.33% drop per 1 MPa growth of pressure.

5. Conclusions

In this study, thermodynamic analyses of the LAES system integrated with a LNG evaporation process (denoted as LAES-LNG) has been carried out. The influences of charging pressure and discharging pressure on the system performance are discussed and sensitivity analyses on the recovered cold are made under different charging and discharging pressures, which are helpful to guild the practical implements.

The LAES-LNG system makes full advantage of high-grade cold energy from LNG to enhance the air liquefaction. Simulation results illustrate that a higher round trip efficiency, 75-85%, can be achieved, which is 15-35% higher than the current stand-alone LAES system. Liquid air yield obtains a significant improvement up to 0.87. The changes in charging pressure would not significantly affect the liquid air yield thanks to the high-grade cold energy from the LNG. The LAES-LNG system can probably be considered as a solution to enhance the round trip efficiency of the current LAES system and make the LAES more competitive in the large-scale energy storage technologies.

References

- [1] Foley T, Thornton K, Hinrichs-rahlfes R, Sawyer S, Sander M, Taylor R, et al. Renewables 2015 Global Status Report Renewables 2015 Global Status Report 2015 Key Findings. 2015.
- [2] Rodrigues EMG, Godina R, Santos SF, Bizuayehu AW, Contreras J, Catalão JPS. Energy storage systems supporting increased penetration of renewables in islanded systems. *Energy* 2014;75:265–80.
- [3] Chen H, Cong TN, Yang W, Tan C, Li Y, Ding Y. Progress in electrical energy storage system: A critical review. *Prog Nat Sci* 2009;19:291–312.
- [4] Ameer B, T'Joel C, De Kerpel K, De Jaeger P, Huisseune H, Van Belleghem M, et al. Thermodynamic analysis of energy storage with a liquid air Rankine cycle. *Appl Therm Eng* 2013;52:130–40.
- [5] Morgan R, Nelmes S, Gibson E, Brett G. Liquid air energy storage - Analysis and first results from a pilot scale demonstration plant. *Appl Energy* 2015;137:845–53.
- [6] Morgan R, Nelmes S, Gibson E, Brett G. An analysis of a large-scale liquid air energy storage system. *Proc Inst Civ Eng - Energy* 2015;168:135–44.
- [7] Sciacovelli A, Vecchi A, Ding Y. Liquid air energy storage (LAES) with packed bed cold thermal storage – From component to system level performance through dynamic modelling. *Appl Energy* 2017;190:84–98.
- [8] Guizzi GL, Manno M, Tolomei LM, Vitali RM. Thermodynamic analysis of a liquid air energy storage system. *Energy* 2015;93:1639–47.
- [9] Li Y, Cao H, Wang S, Jin Y, Li D, Wang X, et al. Load shifting of nuclear power plants using cryogenic energy storage technology. *Appl Energy* 2014;113:1710–6.
- [10] Antonelli M, Barsali S, Desideri U, Giglioli R, Paganucci F, Pasini G. Liquid air energy storage: Potential and challenges of hybrid power plants 2017.
- [11] Peng X, She X, Cong L, Zhang T, Li C, Li Y, et al. Thermodynamic study on the effect of cold and heat recovery on performance of liquid air energy storage. *Appl Energy* 2018;221:86–99.
- [12] Şevik S. An analysis of the current and future use of natural gas-fired power plants in meeting electricity energy needs: The case of Turkey. *Renew Sustain Energy Rev* 2015;52:572–86.
- [13] Smil V. *Natural Gas: Fuel for the 21st Century*. 2015.
- [14] Wei L, Geng P. A review on natural gas/diesel dual fuel combustion, emissions and performance. *Fuel Process Technol* 2016;142:264–78.
- [15] Kanbur BB, Xiang L, Dubeş S, Choo FH, Duan F. Cold utilization systems of LNG : A review 2017;79:1171–88.