

3-D Printed Filter Based On Helical Resonators With Variable Width

Shang, Xiaobang; Li, Jin; Guo, Cheng; Lancaster, Michael; Xu, Jun

DOI:

[10.1109/MWSYM.2017.8058936](https://doi.org/10.1109/MWSYM.2017.8058936)

Document Version

Peer reviewed version

Citation for published version (Harvard):

Shang, X, Li, J, Guo, C, Lancaster, M & Xu, J 2017, 3-D Printed Filter Based On Helical Resonators With Variable Width. in *2017 IEEE MTT-S International Microwave Symposium, IMS 2017.*, 8058936, Institute of Electrical and Electronics Engineers (IEEE), pp. 1587-1590, 2017 IEEE MTT-S International Microwave Symposium, IMS 2017, Honolulu, United States, 4/06/17. <https://doi.org/10.1109/MWSYM.2017.8058936>

[Link to publication on Research at Birmingham portal](#)

Publisher Rights Statement:

(c) 2017 IEEE. Personal use of this material is permitted. Permission from IEEE must be obtained for all other users, including reprinting/republishing this material for advertising or promotional purposes, creating new collective works for resale or redistribution to servers or lists, or reuse of any copyrighted components of this work in other works
Checked for eligibility: 27/02/2017
Embargoed until end of conference.

General rights

Unless a licence is specified above, all rights (including copyright and moral rights) in this document are retained by the authors and/or the copyright holders. The express permission of the copyright holder must be obtained for any use of this material other than for purposes permitted by law.

- Users may freely distribute the URL that is used to identify this publication.
- Users may download and/or print one copy of the publication from the University of Birmingham research portal for the purpose of private study or non-commercial research.
- User may use extracts from the document in line with the concept of 'fair dealing' under the Copyright, Designs and Patents Act 1988 (?)
- Users may not further distribute the material nor use it for the purposes of commercial gain.

Where a licence is displayed above, please note the terms and conditions of the licence govern your use of this document.

When citing, please reference the published version.

Take down policy

While the University of Birmingham exercises care and attention in making items available there are rare occasions when an item has been uploaded in error or has been deemed to be commercially or otherwise sensitive.

If you believe that this is the case for this document, please contact UBIRA@lists.bham.ac.uk providing details and we will remove access to the work immediately and investigate.

3-D Printed Filter Based On Helical Resonators With Variable Width

Xiaobang Shang¹, Jin Li², Cheng Guo², Michael J. Lancaster¹, and Jun Xu²

¹University of Birmingham, Birmingham, B15 2TT UK

²University of Electronic Science and Technology of China, Chengdu, 610054 China

Abstract—This paper presents a helical resonator bandpass filter produced using a stereolithography (SLA) based 3-D printing technique. The filter is formed of four coupled helical resonators, and for each resonator the helix is fixed at both ends so that the resonator is less prone to vibration. The helix is designed to have variable width and this yields enhanced performance in terms of a higher unloaded quality factor and a spurious resonance at higher frequencies. Such a helix is ideally suited to 3-D printing which allows easy production of complex structures. The whole filter is printed from a resin, then plated with metal, and tested. The measured result has a good agreement with simulations.

Index Terms—Helical resonator, bandpass filter, 3-D printing, stereolithography

I. INTRODUCTION

Helical resonator filters have widespread applications in communication systems operating in the VHF and UHF ranges [1]-[2]. Helical resonators are superior to resonators based on lumped elements, in terms of offering a higher unloaded quality factor (in the range of 500 to 2000) [3]. In contrast to conventional coaxial resonators, helical resonators have advantages of smaller size and volume, at the expense of degrading quality factor. At these frequency bands, surface acoustic wave (SAW) resonators are also very popular due to their compact size, however, they are more expensive to make and are not capable of handling high power [1]. Therefore, helical resonator is an attractive choice to construct filters for applications demanding a relatively high quality factor, a good power handling capability, and a practical size. High performance helical resonator filters, to cope with a variety of challenging specifications, have been widely demonstrated (e.g. [1]-[5]). However, the construction and assembling of helical resonator filters is not straightforward. To form an accurate helical structure, usually a mould with grooves is CNC machined first, and then copper wire is wound along the grooves to obtain the desired shape. Tuning screws are normally employed for helical filters to compensate for the fabrication inaccuracy. In addition, the connection between the helix and the shield (i.e. walls of the cavity) is crucial to maintain a high quality factor for the resonator [6]; to achieve this a good soldered joint is usually performed after assembling the filter.

3-D printing is a great alternative technique for ease of fabrication of helical resonator filters. 3-D printing is capable of producing the helix directly (without the need of a mould). In addition, the whole filter can be printed into a single standalone piece, so that all the helices can be perfectly joined

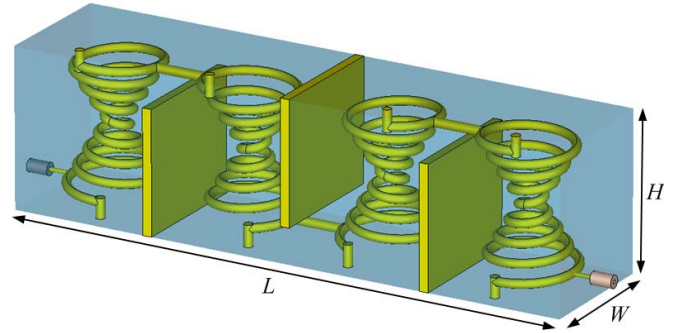

Fig. 1. Configuration of the filter based on four helical resonators. The cavities are designed to have a square cross section. Tap coupling is utilized to provide coupling into the filter as well as inter-resonator coupling. $L=185$ mm, $W=44$ mm, $H=52$ mm.

with the shield; eliminating the need of soldering. Different 3-D printing techniques exist, and among them the three most popular in the microwave field are fused deposition modeling, stereolithography (SLA) and selective laser sintering or melting (SLS/SLM) [7]. The former two print from non-conductive polymers or resins and hence require an additional metal coating process, and the latter is capable of printing all metal structures directly. Up to date, the SLA process delivers the highest resolution and has been found to produce high quality components, with waveguide filters operating at frequencies as high as W-band [8].

In this paper, we present a SLA printed 4th order helical resonator filter (see Fig. 1). To the extent of our knowledge, this is the first ever reported helical resonator filter produced using 3-D printing. As shown in Fig. 1, the helices are connected to the cavities walls at both ends, and are effectively half-wavelength helical transmission lines. This is different to conventional quarter-wavelength helical resonators, which are shorted at one end and opened at the other. Half-wavelength resonators are chosen here as such configuration is less prone to vibration. Increased stability can also be achieved by using low loss dielectric as coil formers to support the helix [6]. However, this approach reduces the power handling capability and degrades the quality factor of the resonator. Half-wavelength helical resonators have been utilized to construct oscillators [9], however it has rarely been used for filters. Additionally, here the helix is designed to have variable width. Such helix exhibits a higher quality factor and pushes the first spurious resonance to a higher frequency, whereas at the same time presents no additional difficulty in fabrication via 3-D printing. No helix with varying width has been reported in

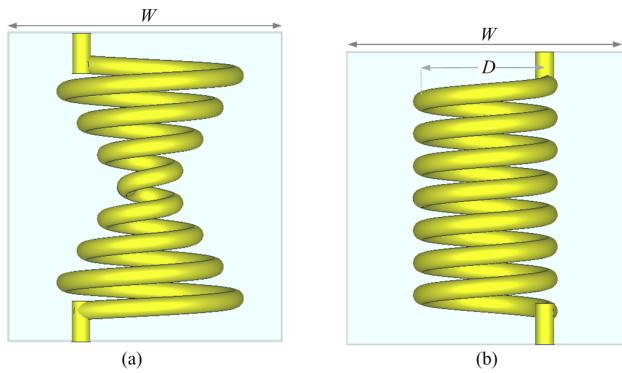

Fig. 2. Diagrams of helical resonators. Helix with (a) variable width and (b) constant width. Diameter of the coil is 3 mm. $W=44$ mm, $D=20$ mm.

open literature, except for a quarter-wavelength helical filter designed for enhanced power handling capability [2].

II. HELICAL RESONATOR

Fig. 2 shows the helical resonators which consist of a helical transmission line with both ends connected to the cavity. Such configuration stabilizes the helix without the need of any additional support structure. As mentioned before, a helix shorted at both ends is equivalent to a half-wavelength resonator. Initial dimensions of the helix are calculated according to the design equations given in [6] and [10]. Two types of helixes are shown in Fig. 2; one with variable width and the other constant width. Both resonators are analyzed in CST (version 2016) using the eigen mode solver, and their results are presented in Table I. Note that the simulation results are obtained subject to the same settings. Since unloaded quality factor (Q_u) of the resonator increases with the cavity size [10], both helixes are placed in a square cavity with the same size. It can be found from Table I that the helix with varying width exhibits a higher Q_u and a spurious resonance at higher frequencies, and it is therefore utilized in this work.

In comparison with a conventional quarter-wavelength resonator, a half-wavelength helical resonator increases the stability at the cost of worsening spurious resonance. For a conventional quarter-wavelength helix, the first spurious resonance occurs at the frequency which is approximately 3 times the resonant frequency of dominant mode. This is significantly higher than that of a half-wavelength helix. Therefore, the helical resonator in Fig. 2 (a) is not an ideal choice to construct filters for applications demanding a wide stopband free of spurious resonances. Noteworthy, 3-D printing also has no problem with printing the quarter-wavelength resonators.

A helical filter has excellent power handling capability, and half-wavelength resonators could achieve further improvement on this. The power a filter can handle is inversely proportional to the square of the maximum electric field strength (i.e. E_{\max} in Table I) [5], [11]. CST simulations show that E_{\max} of the half-wavelength resonator is less than half of E_{\max} of the

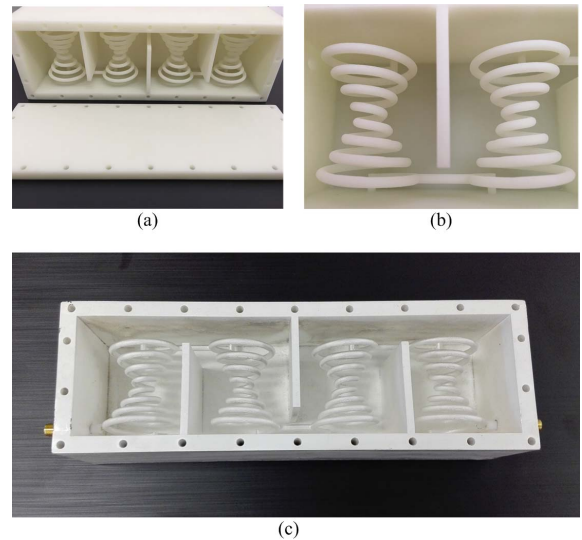

Fig. 3. Photograph of the 3-D printed filter. (a) Filter before metal coating; (b) enlarged view of two coupled helical resonators; (c) filter after metal coating.

TABLE I
COMPARISON BETWEEN HELICAL RESONATORS IN FIG. 2 WITH THE SAME RESONANT FREQUENCY OF 0.5GHZ

Resonators	Q_u	E_{\max}	1 st spurious mode
Variable width	1731	3.11×10^8 V/m	0.92 GHz
Constant width	1660	2.57×10^8 V/m	0.83 GHz

equivalent quarter wavelength resonator. This indicates the power handling capability has been greatly enhanced using half-wavelength helical resonator.

III. FILTER DESIGN

The filter is formed with four coupled helical resonators and is designed to have a Chebyshev response with 20 dB return loss over the passband. The passband is centered at 0.5 GHz with a fractional bandwidth (FBW) of 4%. The non-zero coupling coefficients between resonators and the external quality factor (Q_e) of the first and last resonators are calculated to be [12] $M_{12}=M_{34}=0.0365$, $M_{23}=0.028$, $Q_e=23.285$. The dimensions of the filter are extracted from these coupling values by following the procedure in [12].

The filter together with a pair of SMA connectors is illustrated in Fig. 1. Tap coupling is employed to provide the external couplings for the filter, and the position of the tap can be adjusted to obtain the desired Q_e . Adjacent helixes are wound in the opposite direction so that the filter structure is symmetrical. Couplings between resonators are realized using lines with the same diameter as the helix, instead of apertures or probes. The position where the lines are connected determines the coupling strength. Briefly, strong couplings can be

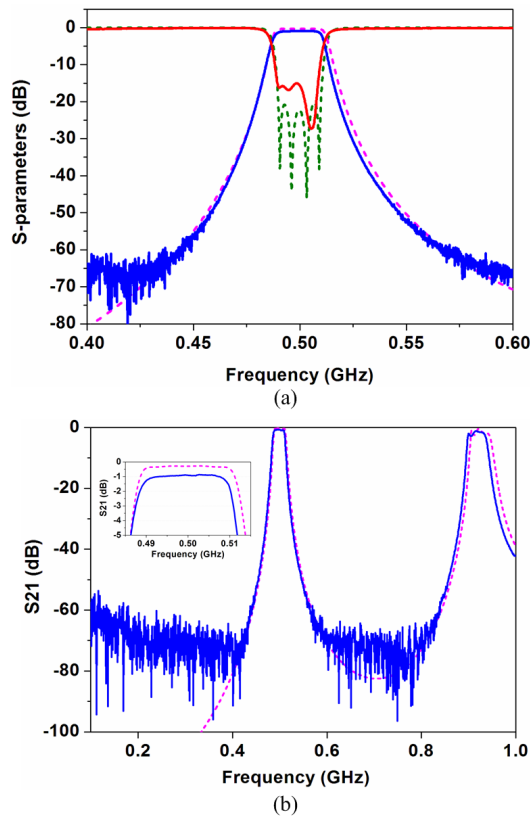

Fig. 4. Measured (solid lines) and simulated (dashed lines) results of the 3-D printed filter. (a) Responses over the frequency range of 0.4–0.6 GHz; (b) S_{21} response over a wider frequency range. The insert shows the enlarged view of the insertion loss performance across passband.

obtained by placing the line at the positions where the current is high, and vice versa. A shield is placed between resonators to avoid any unwanted couplings. Couplings using lines can achieve a wide range of coupling coefficients, in other words filters with considerably different FBW are feasible. In addition, such structures provide the filter with additional stability, and can be readily implemented using 3-D printing. Full-wave simulation of the filter is carried out in CST and the simulation results can be found in Fig. 4.

IV. MEASUREMENT AND DISCUSSIONS

The filter is printed from a resin (Somos [13]) using a SLA printer, and is subsequently coated with around $25 \mu\text{m}$ thick copper and $1 \mu\text{m}$ thick silver. The skin depth at 0.5 GHz is calculated to be $2.836 \mu\text{m}$ using the conductivity of silver ($6.3 \times 10^7 \text{ S/m}$). The specified thickness of metal plating is therefore much larger than 5 times of skin depth. Fig. 3 shows the 3-D printed filter before and after metal plating. The filter is formed of two pieces, one piece is the whole filter without the lid, the other the lid itself, this is to facilitate the metal plating process which requires access to inner surfaces. After metallization, these two pieces are assembled using bolts through holes 3-D printed through the whole side of the structure.

Fig. 4 shows the measurement results of the 3-D printed filter. It can be observed that the measured performance has a good agreement with simulations. The measured return loss is better than 15 dB across the whole passband. The measured average passband loss is around 0.9 dB, which is around 0.6 dB higher than the expected value from simulations using conductivity of silver. The surface roughness of the printed filter is measured to be around $1 \mu\text{m}$. This reduces the effective conductivity to $5.1 \times 10^7 \text{ S/m}$, and yields a small additional loss of around 0.03 dB. The difference between measured and simulated insertion loss is mainly attributed to the low quality metal coating which has a non-uniform thickness, due to the metal coating process being under development. The insertion loss problem can be solved once the metal coating process is well developed. Alternatively, a commercial process, which has yielded good results in the past (e.g. [7]–[8]), could be employed to achieve the desired low insertion loss.

In this work, the helical filter is printed from polymer and this yields a considerable reduction in weight (total weight of 3-D printed filter is only around 15% of that made from solid copper). However, the polymer prevents the filter from being utilized for applications involving high power or requiring high operating temperature. In such a scenario, the filter could be printed from metal using selective laser melting.

V. CONCLUSION

A 3-D printed helical resonator filter has been described. The measured performance has good agreement with simulations, except for the higher-than-expected insertion loss which is a result of the low quality metal coating. Nevertheless, this work has clearly demonstrated the great flexibility offered by 3-D printing which enables novel helical resonator filters with complex structures as well as enhanced performance. This work also shows that 3-D printing can ease the fabrication of helical filters significantly, and is a great alternative for small to medium batch size production of some microwave devices.

ACKNOWLEDGMENT

This work was supported by the U.K. Engineering and Physical Science Research Council (EPSRC) under contract EP/M016269/1.

REFERENCES

- [1] M. Yu and V. Dokas, “High performance helical resonator filters,” in *34th European Microw. Conf.*, Amsterdam, The Netherlands, Oct. 2004, pp. 989–992.
- [2] G. Salza, G. Goussetis, C. Vicente, *et al*, “Helical resonator with modulated radius for improved multifactor threshold: numerical and experimental results,” in *46th European Microw. Conf.*, London, UK, Oct. 2016, pp. 233–236.
- [3] D. Psychogiou, D. Peroulis, “Tunable VHF miniaturized helical filters,” *IEEE Microw. Theory Techn.*, vol. 62, no. 2, pp. 282–289, Feb. 2014.

- [4] P. Zhao, Z. Li, J. Wu, K. L. Wu, and Y. Cui, "A compact wideband UHF helical resonator diplexer," in *2016 IEEE MTT-S Int. Microw. Symp. Dig.*, San Francisco, USA, May 2016, pp. 1–3.
- [5] Y. Wu, R. Gajaweera, and J. Everard, "Dual-band bandpass filter using helical resonators," in *46th European Microw. Conf.*, London, UK, Oct. 2016, pp. 237–240.
- [6] A. Zverev, *Handbook for filter synthesis*, New York, Wiley, 1967.
- [7] M. D'Auria, W. J. Otter, J. Hazell, *et al.*, "3-D printed metal-pipe rectangular waveguides," *IEEE Trans. Compon. Packag. Manuf. Technol.*, vol. 5, no. 9, pp. 1339–1349, Sept. 2015.
- [8] X. Shang, P. Penchev, C. Guo, *et al.*, "W-band waveguide filters fabricated by laser micromachining and 3-D printing," *IEEE Trans. Microw. Theory Techn.*, vol. 64, no. 8, pp. 2572–2580, Aug. 2016.
- [9] J. K. A. Everard, K. K. M. Cheng, and P. A. Dallas, "High-Q helical resonator for oscillators and filters in mobile communication systems," *Electron. Lett.*, vol. 25, no. 24, pp. 1648–1650, Nov. 1989.
- [10] N. P. Spencer, "A review of the design of helical resonator filters," *J. Inst. Electron. Radio Eng.*, vol. 57, no. 5, pp. 213–220, Sept. 1987.
- [11] M. Yu, "Power-handling capability for RF filters," *IEEE Microw. Magazine*, vol. 8, no. 5, pp. 88–97, Oct. 2007.
- [12] J.-S. Hong and M. J. Lancaster, *Microstrip Filters for RF/Microwave Applications*, New York, NY, USA: Wiley, 2001.
- [13] DSM's Somos[®] Imagine 8000, www.dsm.com