

Availability and processing of recycled aggregates within the construction and demolition supply chain:

Silva, R.V.; de Brito, J.; Dhir, Ravindra K.

DOI:

[10.1016/j.jclepro.2016.12.070](https://doi.org/10.1016/j.jclepro.2016.12.070)

License:

Creative Commons: Attribution-NonCommercial-NoDerivs (CC BY-NC-ND)

Document Version

Peer reviewed version

Citation for published version (Harvard):

Silva, RV, de Brito, J & Dhir, RK 2017, 'Availability and processing of recycled aggregates within the construction and demolition supply chain: A review', *Journal of Cleaner Production*, vol. 143, pp. 598-614.
<https://doi.org/10.1016/j.jclepro.2016.12.070>

[Link to publication on Research at Birmingham portal](#)

General rights

Unless a licence is specified above, all rights (including copyright and moral rights) in this document are retained by the authors and/or the copyright holders. The express permission of the copyright holder must be obtained for any use of this material other than for purposes permitted by law.

- Users may freely distribute the URL that is used to identify this publication.
- Users may download and/or print one copy of the publication from the University of Birmingham research portal for the purpose of private study or non-commercial research.
- User may use extracts from the document in line with the concept of 'fair dealing' under the Copyright, Designs and Patents Act 1988 (?)
- Users may not further distribute the material nor use it for the purposes of commercial gain.

Where a licence is displayed above, please note the terms and conditions of the licence govern your use of this document.

When citing, please reference the published version.

Take down policy

While the University of Birmingham exercises care and attention in making items available there are rare occasions when an item has been uploaded in error or has been deemed to be commercially or otherwise sensitive.

If you believe that this is the case for this document, please contact UBIRA@lists.bham.ac.uk providing details and we will remove access to the work immediately and investigate.

Accepted Manuscript

Availability and processing of recycled aggregates within the construction and demolition supply chain: A review

R.V. Silva, J. de Brito, R.K. Dhir

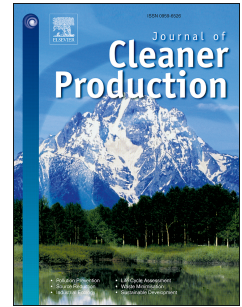

PII: S0959-6526(16)32135-7

DOI: [10.1016/j.jclepro.2016.12.070](https://doi.org/10.1016/j.jclepro.2016.12.070)

Reference: JCLP 8645

To appear in: *Journal of Cleaner Production*

Received Date: 7 June 2016

Revised Date: 5 December 2016

Accepted Date: 14 December 2016

Please cite this article as: Silva RV, de Brito J, Dhir RK, Availability and processing of recycled aggregates within the construction and demolition supply chain: A review, *Journal of Cleaner Production* (2017), doi: 10.1016/j.jclepro.2016.12.070.

This is a PDF file of an unedited manuscript that has been accepted for publication. As a service to our customers we are providing this early version of the manuscript. The manuscript will undergo copyediting, typesetting, and review of the resulting proof before it is published in its final form. Please note that during the production process errors may be discovered which could affect the content, and all legal disclaimers that apply to the journal pertain.

Availability and processing of recycled aggregates within the construction and demolition supply chain: A review

R. V. Silva¹, J. de Brito² and R. K. Dhir^{3,4}

¹ CERIS-ICIST, Instituto Superior Técnico, Universidade de Lisboa, Av. Rovisco Pais, 1049-001 Lisboa, Portugal; e-mail: rui.v.silva@tecnico.ulisboa.pt

² CERIS-ICIST, Instituto Superior Técnico, Universidade de Lisboa, Av. Rovisco Pais, 1049-001 Lisboa, Portugal; e-mail: jb@civil.ist.utl.pt, Corresponding author

³ School of Civil Engineering, University of Birmingham, B15 2TT, UK; Phone: +44 121 4145075, email: r.k.dhir@bham.ac.uk

⁴ Applying Concrete Knowledge, 1A Blakeney Avenue, Birmingham, B17 8AP, UK; Phone: +44 121 4278108/8187, email: r.k.dhir@bham.ac.uk

Abstract: As a response to the great disparity in the recycled aggregates (RA) evaluated in most investigations and those sourced from recycling plants, this paper presents an overview on the subject and seeks to provide information on the present waste issue in the construction life cycle. Several factors related to the wider recognition and use of RA in construction are also described and analysed in this paper, including the main barriers to reuse and recycling, economic and environmental impacts, the choice of demolition methodology, the recycling procedure and certification of the final product. Increased governmental intervention, with ensuing strict legislation and comprehensive standardization, have been found to be key drivers for a greater pro-active engagement of construction and demolition related entities. Furthermore, with recent developments on the classification of RA, which can facilitate certification, it will become increasingly easy to increase the stakeholders confidence on the products' quality and resulting materials' predictable performance, consequently increasing demand for a technically feasible and potentially more economical substitute to their natural counterparts.

Keywords: Construction and demolition waste, recycled aggregates, sustainability, environmental impact, selective demolition, certification.

1 Introduction

The construction and demolition industry is responsible for the production of immense quantities of waste, the increasing volume of which has become unbearable from the environmental, economic and social viewpoints. In the EU alone, it accounts for approximately 30% of the total waste generated (Eurostat, 2015). In 2003, the Environmental Protection Agency (EPA, 2014) estimated that the production of construction and demolition wastes (CDW) was about 170 million tonnes in the USA, while, in China, it was of 120 million tonnes, in 2006 (Zhao and Rotter, 2008).

CDW arise from activities such as the construction and total or partial demolition of buildings and infrastructures, disaster debris, road planning and maintenance activities. These consist of materials including concrete, bricks, excavated soil, metals, glass, gypsum, wood, plastic, asbestos and various polymers, many of which can be recycled. However, the lack of knowledge on the composition and other characteristics (i.e. quantity, quality, type and real cost) by many who manage CDW, generally results in the dumping of huge quantities of potentially reusable/recyclable materials, which could be an alternative to their natural counterparts. Furthermore, most small and medium enterprises, which correspond to the largest portion of the construction and demolition industries, want to perform the job as quickly and as cheaply as possible (CIB, 2003) and are unaware that most of these wastes are avoidable and that following the conventional approach often reduces revenues.

Aside from the general lack of knowledge on the proper disposal approach, in many cases, the aforementioned companies are not compelled enough to reduce CDW generation and find added-value to it, due to insufficient legislation or simply have no choice other than disposal by landfill. A great amount of time and experience are needed for a waste management system to fully develop into a reliable, skilful, marketable and sustainable industry, which is one of the reasons why so many feel discouraged in venturing into the reuse and recycling market. Even in a context in which

one of the stakeholders would be interested in adopting a more ecological stance, this would only be a half measure, since it is essential that all parties involved in the process (manufacturers, clients, contractors, designers and planners) play their part for this attempt to grow into a fully sustainable system.

In spite of the extensive literature concerning the influence of recycled aggregates (RA) on the properties of several construction materials, the aggregates used in these studies are mostly laboratory made and uncontaminated versions of the reality. In reality, RA from CDW recycling plants can exhibit widely varied composition, be highly contaminated, uncertified and thus incapable of being used in high-grade applications (Rodrigues et al. 2013; Bravo et al. 2015). Therefore, this paper presents an overview seeking to expose the present waste issue in the construction life cycle, specifically from the moment in which CDW is generated until its acceptance in recycling plants, ending with some recommendations for future research that can guide the industry towards a more sustainable practice. Several factors related to the wider recognition and use of RA in construction are also analysed in this paper, including the main barriers to reuse/recycling, economic and environmental impacts, types of demolition, CDW recycling process and certification of the final product.

2 Economic viability and environmental impacts of recycling CDW

As people are becoming better educated and with the overflow of information on global, regional and local issues, individuals now have a stronger influence on decision-making via such means as the media, pressure groups and communications systems, particularly websites and blogs. By identifying and understanding international, national and local issues, people are now demanding that their governments adopt the concept of sustainable development and put it into practice. Organizations that use sustainability concepts as part of their management systems tend to be more aware of developing trends and events and are more flexible and adaptable to change, which makes them more competitive (Bond, 2005). Still, in most countries, waste management of CDW is unsustainable, from economic and environmental

viewpoints, and shows significant resistance to positive modifications.

2.1 Barriers

In spite of being widely known (Figure 1) and with reasonably easy solutions, it is still difficult to overcome the barriers that prevent the wider use of RA in construction. Indeed, even though the reincorporation of processed CDW is perfectly sound for standard practice, most of the known obstacles for this approach remain in place usually for economic reasons. Many entities still sell NA at particularly low prices because the raw material's taxation does not consider the actual extraction's environmental impact. Furthermore, the gate fee at CDW recycling plants is not sufficiently alluring to discourage illegal dumping activities.

The advantages, both economic and environmental, of using RA as an alternative to NA are greatly affected by transportation (Braga, 2015). Owing to the potentially great distances between demolition sites to the nearest CDW recycling plant, haulage distances may significantly increase the cost and ecologic footprint of RA. As a result, the attractiveness of using RA to concrete manufacturers and contractors will greatly decrease. Still, depending on the sites' raw material availability and their target construction application, mobile recycling plants are preferred to stationary ones thereby practically eliminating haulage operations by road.

Since the choice of sending CDW to certified recycling plants largely depends on its economic appeal, which mainly depends on road haulage distances, it is also possible that many of these manufacturers might not have enough raw materials to sustain their operations and answer existing demand. From another perspective, even if a recycling plant has enough material to process, it is also possible that there may not be enough consumers' demand for the stocked material thereby delaying operations due to lack of storage space or even endangering that facility's economic sustainability.

In most cases, distrust concerning the RA's technical feasibility is claimed by clients, concrete producers and contractors. Similarly to what happens in many other scientific fields, lack of confidence is

typically complemented by lack of enlightenment on the subject matter. Assuming that the product complies with high-quality standards, the use of RA in structural concrete manufacture is widely accepted in the scientific community as a realistic alternative to NA (Nagataki et al., 2004; Pedro et al., 2014). In fact, experience has shown that, apart from the insufficient fiscal incentives, one of the main excuses for not considering the use of RA is the high inconsistency of their properties. This said, it is also true that the professionals working in most recycling plants are often either uninterested in producing reasonably high-quality RA for high-grade construction applications or are simply unaware of the most appropriate processing methods to obtain them. In both cases, since the quality of the final product may vary daily and normally low, distrust concerning its technical feasibility will endure. However, one must fully acknowledge that this variability in quality will always exist, which can, nonetheless, be appraised based on their most basic physical properties (Silva et al., 2014b). In all stages of a construction and demolition life cycle, waste materials must be sorted on the basis of their nature and characteristics, in order to separate potentially high quality RA from low quality ones. By doing so, a wide array of recycled products with varying, yet certifiable, quality becomes commercially available, which can be used in their most suitable application (Figure 2).

There is a general belief that the environmental impact of CDW beneficiation is greater than that of NA. In spite of this being accurate in circumstances in which the adhered mortar of recycled concrete aggregates (RCA) is removed by heating it to very high temperatures alongside mechanical processing, when treated with the same techniques normally applied to conventional aggregates, RA display a considerably lower carbon footprint (Braga, 2015).

Despite the fact that existing standards and specifications (BRE, 1998; DAfStb, 1998; RILEM, 1994) permit applying RA in concrete manufacture, these exhibit restricting limitations to the characteristics and amount of RA to be used or deliver a vague concept of the future performance of recycled aggregate concrete (RAC). Indeed, the main codes (ACI-318, 2014; EHE-08, 2010; EN-1992-1-1, 2008) for structural concrete design lack clauses that can allow a better understanding of the potential structural

behaviour of RAC (Goncalves and de Brito, 2010; Silva et al., 2016a; Silva et al., 2016b). Bearing in mind that concrete producers and designers strictly follow these codes, a revision is vital in order for them to fully grasp the implications of incorporating RA on the performance of concrete thereby contributing to a greater confidence in the material and use of a greater amount of value-added CDW in construction.

2.2 Financial incentives

Naturally, it is always best to strive for an increasingly “green” culture. However, faced with an innovative business opportunity, especially one that uses recycled products, one must also assess its economic viability. From a public policy perspective, the implementation of specific taxes, such as taxing NA, can be motivated by both fiscal and environmental interests. From an economic efficiency perspective, the main purpose of taxing NA is to raise revenues without distorting economic activities. In practice, this implies that goods with a relatively steady price should be taxed higher than goods with higher price fluctuations. The demand for NA normally leads to steady prices, partly because there are few substitutes and the investment in obtaining and processing raw materials is quite high (Söderholm, 2011).

Taxing NA can also be prompted by environmental reasons. One must, first, understand the underlying truth that the economic system is a subsystem of the environment (Tietenberg, 2002). In other words, economic activities cannot exist without the materials that the environment provides, though the environment may well exist in the absence of human economic activity. In essence, increasing extraction of natural resources results in more harmful emissions and solid wastes, the accumulation of which may go far beyond Nature’s regenerative ability, thereby endangering the future supply of natural resources. For this reason, processing CDW into RA is an absolute necessity, in order to prevent unnecessary accumulation of waste in the environment and relieve the huge consumption of NA.

The main benefits of taxing natural resources, from an environmental perspective, are (Söderholm,

2011): preventing raw material depletion; decreasing waste production and other pollutant emissions during extraction and; encouraging the use of upgraded CDW. The first major benefit of NA taxation is to prevent resource depletion, which is a prime concern when it comes to overexploitation of non-renewable resources. If the collection of a resource is taxed, mining and quarrying activities decrease and will foster a more efficient use of NA, ultimately leading to lower pollutant emissions and waste production. Furthermore, NA with higher costs compels consumers to look for other more sustainable alternatives, specifically processed CDW, which closes the full cycle (“cradle-to-cradle” approach). Furthermore, since CDW recycling tends to be less energy-intensive than natural resource extraction (Estanqueiro et al., 2016), it also leads to fewer emissions besides avoiding the disposal of solid waste.

The UK aggregate levy, which currently stands at £2.00/tonne, has been in effect since April the 1st, 2014, and has been applied to businesses that extract natural materials. For this reason, exemptions were reinstated with the objective of encouraging aggregate recycling, and the use of waste and by-products from other processes instead of natural aggregates.

Besides NA taxation, a landfill tax, the rate of which has increased significantly in some countries, is an effective approach to encourage construction and demolition industries to produce less waste and to recover/recycle materials from CDW. The UK, for example, introduced a landfill tax in 1996 that is applied to waste that is disposed of in licensed landfills (Hurley et al., 2001) and seeks to reflect, as much as possible, the environmental impact of carrying out improper waste disposal. The UK landfill tax, which increases every year, currently stands at £2.65 per tonne of material exhibiting loss on ignition (LOI) lower than 10% (which corresponds to almost all CDW), whereas the standard rate is £84.4 (GOV.UK, 2016). Analyses on the success of the landfill taxation in the Netherlands also suggest that it is an effective measure to direct waste to valuable alternatives (Bartelingsa and Linderhofb, 2006). It was also observed that increasing landfill taxes and fees drives waste suppliers towards investing in separate collection systems for different recovery and recycling options (EEA, 2009). Fur-

thermore, the experience obtained from three case studies (WRAP, 2003a; 2003b; 2004), apart from demonstrating the technical viability of reusing RA from recycling plants located closer to the construction site, also showed considerable savings in transportation costs and in landfill tax by the recycled and secondary materials' suppliers.

During the demolition phase, by using a deconstruction approach during the decommissioning of a building or structure, it is possible to retrieve a greater amount of reusable materials and all associated revenues. Naturally, the amount of materials reclaimed during construction or demolition will continue to rise if component reuse in mainstream construction also increases. A comparison between the reclamation and recycling methods shows that the first may involve less processing, greater employment and more efficient use of resources than the second (Hurley et al., 2001). Therefore, if separating components during construction and demolition activities became a standard procedure, it would certainly increase the amount of reclaimed elements and thus encourage their greater use in new projects.

The results of the BigREc Survey, on the reclamation industry in the UK (CRWP, 2007), showed that, in 2007, apart from over 2.2 million tonnes of components having been reclaimed or salvaged, which avoided their deposition in landfills, it also employed over 25,000 individuals and exhibited a revenue of over £360 million (Table 1).

Tam (2008) carried out a detailed comparative analysis of the costs and benefits of conventional practice of CDW disposal relative to a recycling approach. In that study, conventional practice means that CDW are dumped in landfills and concrete is produced with natural resources (energy is wasted in both the disposal of CDW and the production of NA for concrete manufacture). The proposed recycling method consisted of sending CDW to processing plants (i.e. reduced NA extraction-related energy and amount of landfilled materials) the result of which would be used in concrete production. After having conducted detailed interviews with the staff of various construction and demolition companies, recycling plants and landfills, the results showed that the recycling

method had a positive net benefit of nearly \$31 million (Australian dollars) per year, while the conventional method had a negative net benefit of about \$44 million per year.

Table 1 - Size of the reclamation industry (CRWP, 2007)

Sector	Revenue (£ × 10 ³)	Amount (tonnes)	Employment
<i>Reclaimed and salvaged materials</i>			
Iron and steel	2,026	22,000	730
Wood	4,645	49,000	7,126
Beams	10,192	286,000	5,310
Bricks	117,029	847,800	1,810
Roofing	9,349	100,670	790
Stone	21,625	573,700	1,201
Flooring	7,205	19,900	1,620
Paving	12,924	178,650	1,043
<i>Architectural elements</i>			
Stone	21,595	13,000	729
Wood	26,126	26,150	2,212
Iron and steel	15,497	17,400	424
Terracotta	803	320	95
<i>Ornamental antiques</i>			
Stone	42,954	38,400	597
Wood	19,348	32,400	429
Iron	18,909	14,800	542
Terracotta	16,714	6,400	437
<i>Old bathrooms</i>	15,401	6,500	725
Total	362,342	2,233,090	25,820

Coelho and de Brito (2013a, b) studied the economic viability of a CDW recycling plant in the Lisbon Metropolitan area of Portugal. This plant, with a capacity of 350 tonnes/hour and the technology required to produce high-quality RA, would be capable of separating all main components from a complex combination of debris and discarding (non-)hazardous contaminants and wet sludge carrying ultra-fine particles. Several scenarios for the economic viability were tested, in which the main parameters were: the plant's capacity; input gate fee; RA sale price; rejected materials landfill fee and; amount of delivered mixed and separated CDW. Under the conditions stated in that study, it was found that the amount of input CDW significantly affected the plant's profitability; over a 60-year operation period (i.e. the plant's working life), a recycling facility running at a capacity of merely 85 tonnes/hour would have close to 80% less profit than when working at its full capacity. However, a facility with a full capacity of 350 tonnes/hour could have had a payback period of 1 year in a best-case scenario. Therefore, to guarantee the economic viability of a recycling plant with low payback periods, relatively high design capacities should be preferred. Although investment in a state-of-the-

art large-scale CDW recycling plant may prove to be a multi-million euro enterprise, it has a high profit potential.

2.3 Positive and negative environmental impacts of CDW recycling

Sustainability in construction is about considering all the positive and negative impacts of the operations involved and ensuring that the maximum positive aspects are prioritized. Recovering and recycling CDW have four highly important benefits (Table 2): reduced use of natural resources; reduced transportation to/from extraction sites; reduced consumption of energy and; reduced CDW volume sent to landfill.

Coelho and de Brito (2013c, d) carried out an environmental sensitivity analysis of a CDW recycling plant in the Lisbon Metropolitan Area, Portugal. The impact factors of this installation included incorporated, operation and transport related impacts, which were converted into energy use and CO₂ equivalent emissions. The authors observed that the environmental benefits of installing such a recycling plant are quite substantial, in which the processes involved in recycling and using recycled materials from this plant in construction applications generated nearly 90% less CO₂ equivalent emissions, than when using natural resources. In addition, this recycling method required almost 85% less energy than the conventional approach.

Table 2 - Positive environmental impacts of using RA (Bond, 2005)

Positive environmental impacts	
Reduced use of natural resources	<ul style="list-style-type: none"> • Reduced damage to habitat • Less visual damage
Reduced transportation of natural resources	<ul style="list-style-type: none"> • Reduced greenhouse gas emissions • Reduced pollution emissions • Less use of fossil fuel resources
Reduced energy consumption	<ul style="list-style-type: none"> • Reduced greenhouse gas emissions • Reduced pollution emissions • Less use of fossil fuel resources
Reduced amount of CDW sent to landfill	<ul style="list-style-type: none"> • Less damage to existing habitat • Less visual amenity damage

Though the use of RA will avoid or reduce the aforementioned impacts, recycling plants also have their

own associated carbon footprint, which must be recognized in order to mitigate it. Considering the fact that CDW availability and potential locations for their reuse after processing are likely to be in more urban settings, transport and delivery related impacts associated with CDW recycling are essentially the same as those accompanying road-delivered NA, unless the CDW can be processed and used on the original site (Coelho and de Brito, 2013c). There are also several energy-related costs involved in the manufacturing process of RA (i.e. thermal processing) in some of the more complex CDW recycling plants. Additionally, aggregate washing may involve great amounts of potable water to remove contaminants, which may not be well disposed of and thus likely to pollute groundwater. Therefore, CDW recycling operations are likely to generate the following main environmental impacts (DETR, 2000):

- Land take and ancillary development, such as visual and aesthetic impacts of the recycling plant and material stockpiles, and the loss of natural features and habitats;
- Dust produced during storage, processing and transportation of materials;
- Noise, vibrations, gas emissions and odour derived from processing operations and transportation vehicles;
- Land contamination and water pollution caused by the use of internal combustion engines and lubricants used by the equipment;
- Additional transportation impacts (e.g. road delay, congestion, poorer safety).

2.3.1 Impacts of land take and ancillary development

One of the main impacts of land take and ancillary development is visual, which affects landscape aesthetic especially that related to the recycling facility, the storage of CDW and processed material, and the aspect of screening bunds and vegetation. Since long abandoned industrial sites may provide suitable locations for recycling facilities, efforts must be made to adjust its general aspect to the surrounding environment (DETR, 2000).

2.3.2 Dust

Dust is generated by processing operations, but the impact is likely to be of more concern in close proximity to sensitive receptors (e.g. suburban and urban areas, fragile habitats). The operations that are liable to generate most dust are processing of the materials (e.g. crushing and air-sifting), and collecting and depositing them for storage. Other significant sources of dust are vehicles travelling over unpaved surfaces and airborne dust generated from stockpiles of material in windy conditions. Considerable efforts should be made in mitigating and avoiding the impact of dust, i.e. preventing dust from becoming airborne at the source (DETR, 2000).

2.3.3 Noise and vibration

Like dust, noise and vibration are generated by processing operations and are likely to be of greater concern if the recycling facility is close to sensitive receptors. Although sound and vibrations emanating from these operations are normally not sufficiently strong to cause property damage or injuries to people, they can be quite uncomfortable. The main sources of noise and vibration are the working engines that power on-site crushing and screening equipment plant, as well as vehicles. The impact of material in metal hoppers and chutes of crushers and lorry movements are other sources. Although there is considerable scope for reducing the impacts of noise and vibration, the nature of the operation is such that they cannot be entirely eradicated (O'Mahony, 1990).

2.3.4 Additional transportation impacts

Additionally to the noise, vibration and dust, caused by the transportation traffic, this has other impacts of great concern, including road obstruction, congestion, delay, heightened anxiety, and poorer safety. Although these impacts can be mitigated to some extent, the environmental effects of transportation are likely to be considerable. The transportation and delivery impacts associated with recycling CDW are essentially the same as those associated with road-delivered NA. The exception is when CDW are processed and used on the same site (i.e. mobile recycling facilities) (BRE, 2008).

2.4 Mitigation of environmental impacts

In order to reduce the environmental impact of the construction and demolition industries, several measures may be implemented by following the “reduce, reuse, and recycle” approach (Table 3). A waste minimization philosophy should always be considered, particularly when waste (i) is generated in large volumes (e.g. concrete), (ii) originates from valuable materials (e.g. marble), (iii) has a high salvage value (e.g. metals), or (iv) is toxic (e.g. oils and chemicals). One way of minimizing waste production is by prolonging the life span of materials/components (i.e. higher durability means that it will take longer to replace them with newer ones and thus less waste is produced and fewer resources are consumed). Another effective approach to reduce the environmental impacts of the construction industry consists of closing the full life cycle based on a “cradle-to-cradle” perspective (e.g. in the end of a structure’s life cycle, instead of landfilling all materials, it is possible to add value by sorting and reclaiming/processing so that these materials can be reused/recycled in future constructions (Blengini and Garbarino, 2010). In some countries, this has been encouraged by implementing stricter legislation, requiring the reduction of environmental pollution caused by waste materials, including waste building products. This is achieved by handling and disposing of wastes in an efficient, user-friendly manner and limiting their generation by promoting their use (De Vries, 1995).

Table 3 - Summary of methods used to reduce, reuse and recycle CDW (Guthrie, 1997)

	Reduce	Reuse	Recycle
Construction practices	<ul style="list-style-type: none"> • Purchase reclaimed materials • Focus on reducing raw material usage • Store raw materials to minimize loss, damage and theft 	<ul style="list-style-type: none"> • Separate waste on site (e.g. excavation soil, timber, metals, architectural features, concrete pipes, tiles, bricks, plastics, paper, oils, and paints) • Return packaging and excess materials to suppliers for reuse 	<ul style="list-style-type: none"> • Separate wastes on site for easier processing in recycling plants • Use reclaimed materials generated on site (e.g. excavation soil)
Design innovation	<ul style="list-style-type: none"> • Minimize material use, minimize temporary works, optimize design life, and minimize waste from abortive work, offcuts or damage 	<ul style="list-style-type: none"> • Promote purchase of reused materials • Promote reuse of materials on site, both during and at the end of the project 	<ul style="list-style-type: none"> • Promote use of recycled materials

In spite of the benefits of recycling, CDW recycling plants also present notable impacts and, in order to secure their operation as a sustainable alternative, several preventative and mitigation

measures as a response to the adverse environmental and amenity impacts of RA production have been identified (BRE, 2008; DETR, 2000; Silva, 2015). Prevention, being the best way to reduce environmental impacts, can be achieved by adapting the implementation and enforcement of environmental protection regimes to the location, altering the internal layout of processing sites and using management control. Where an impact cannot be prevented, the mitigation of its effects will be necessary, which can be accomplished by making design and physical alterations.

3 Demolition of a building structure

There are two distinct philosophies for the demolition of buildings and structures: conventional demolition and selective demolition (or deconstruction). Several studies have been published on selective demolition and its technical, economic and environmental implications (ACWMA, 2013; Coelho and de Brito, 2011; Dantata et al., 2005; Guy, 2006; Guy and Gibeau, 2003; Roussat et al., 2009). Even though selective demolition is already standard practice in some countries, in many others it is still looked at as with dubious economic appeal and little practical features.

3.1 Selective demolition

The results of an economic analysis of conventional *versus* selective demolition in a case study (Coelho and de Brito, 2011) showed that the economic feasibility of applying a selective demolition approach greatly depends on a number of factors, including labour costs, market prices, and tipping fees for recovered materials. In spite of this, adopting the selective demolition approach is likely to be more cost-effective than the conventionally used one. Furthermore, from an environmental point of view, the results of a life cycle assessment of various scenarios applying different levels of selective demolition (Coelho and de Brito, 2012) showed that there was a significant reduction of impacts (the tested factors were the amount of heavy metals, acidification, climatic change, nitrification and summer smog). Still, this occurred only when the structure was subjected to an almost complete selective demolition, whereas partial selective demolition (i.e. controlled demolition of non-structural ele-

ments, which were sent to a processing plant, followed by conventional demolition of the rest of the structure and landfilling) could even slightly intensify the impact on the environment, in comparison to the conventional approach, due to increased transportation distances. Therefore, looking to the whole life cycle, in order to mitigate environmental impact, it was estimated that the recycling rate has to increase to over 90% and the resulting materials must be incorporated in the new construction.

In a more recent study (Tam and Lu, 2016) concerning waste management operations practiced in Australia, European Union, Hong Kong and the United Kingdom, the results showed that there has been a clear decrease in the amount of generated waste as a result of increasing efforts towards a “greener” construction industry.

Furthermore, from a technical point of view, considering the different nature of the components normally encountered in CDW (Figure 3), in order to minimize contamination, a high quality control during the selective demolition is viewed as extremely effective. Since this has great importance on the output quality of recycling plants, selective demolition is encouraged by the introduction of strict control procedures and applying different gate fees depending on the composition, amount of contaminants and origin of the CDW (Vyncke and Rousseau, 1993).

Figure 4 presents the concept of a performance-based approach to the use of RA in construction applications with varying requirements, in which, by categorizing RA based on their intrinsic properties rather than on their composition alone, it is possible to maximize the incorporation of RA in their most suitable application without significant loss in performance. Furthermore, classification of RA in easily understandable categories, alongside proper certification, also helps facilitate future client purchases since they will be buying an item appropriate to its future application (e.g. structural concrete may use RA of class A, whereas RA of class D may be used for subgrade, in road construction).

Selective demolition comprises a series of sub-activities, as shown in After the structure has been demolished, steel or wooden beams that were part of the basic structure can finally be removed. At

this stage, some of the steel reinforcing bars can also be removed while crushing concrete members using scissor crushers (the remaining ferrous metals can be recovered later via electromagnets in the recycling plant).

Table 4. Although these sub-activities can take place in any order, or even simultaneously, they are generally organized in the order shown. After selective demolition has taken place and the envelope of the construction has been demolished, there are further sub-activities to consider, which cover the demolition of structures, and the treatment/disposal of wastes.

After the structure has been demolished, steel or wooden beams that were part of the basic structure can finally be removed. At this stage, some of the steel reinforcing bars can also be removed while crushing concrete members using scissor crushers (the remaining ferrous metals can be recovered later via electromagnets in the recycling plant).

Table 4 - Component elements of selective demolition (SymondsGroup, 1999)

	Sub-activity	Materials	Observation
1a	Selective removal of accessible materials with high marketable value	Valuable architectural materials, stained glass, decorative carved doors and wall panelling, decorative wrought iron and tiles, double glazed glass window and door units, electrical fittings, metals	Without proper management, the materials may be stolen or even sent to a landfill
1b	Selective removal of accessible materials, which, if not removed, will cause CDW to be considered as hazardous	Asbestos and other hazardous materials.	This will reduce the amount of CDW that has to go to hazardous landfill
1c	Selective removal of materials, which, if not removed, will lower the value of the remaining CDW when crushed	Wood, plastic, glass, gypsum plaster	This will raise the value of the CDW-derived aggregates subsequently produced
1d	Chemical treatment in situ of exposed building parts, contaminated during the building's life cycle, followed by removal	Surface materials (roofing, walls, floors) that have been subjected to chemical alteration/contamination	This is a relatively new concept/activity. It is only likely to be appropriate in the case of industrial structures

Following the aforementioned steps will ensure that the resulting CDW will largely consist of inert materials, predominantly concrete, mortar, bricks, ceramic materials and gypsum. If these are not necessary on-site for filling or landscaping (thus avoiding transportation of NA or clean soil), then they can be transported to a recycling facility, where they are upgraded for use in other applications, the effectiveness of which also depends on the sorting success during construction and demolition operations. As-

suming that all directly reusable components are separated and the remaining is subjected to categorisation by type of material, resulting CDW are more likely to contain fewer contaminants. Thereafter, upon processing in certified recycling facilities, there is a greater chance of producing high-quality RA.

3.2 Methods and equipment for production and collection of CDW debris

The demolition industry has undertaken significant changes. In the early years, demolition of a structure was a labour intensive, low skill, and poorly regulated activity, dealing mainly with the disassembly and demolition of buildings using simple technologies. Today, following the trend of all major industries, the industry has automated the process by replacing manual labour with machines. This evolution is mainly because of the increasing complexity in building design, advances in plant design, financial pressures from clients, health, safety, and other regulatory and legal requirements.

The ACI Committee 555 (Lamond et al., 2002) produced a report on the removal and reuse of concrete using techniques that conform to the concept of selective demolition. It discusses several steps and equipment required for the deconstruction of a structure, the first step of which requires an evaluation of existing materials. This may be achieved via petrography studies or non-destructive and semi-destructive testing, which can assess the quality, condition and strength of concrete (e.g. surface hardness; penetration resistance techniques; pull-off tests).

Depending on the type of concrete structure (general, mass concrete structures, underground structures, reinforced concrete structures, pre-stressed/post-tensioned structures, pre-tensioned members, separately stressed precast units, monolithic structures, progressively pre-stressed structures), different support structures and demolition methods are required. A number of factors that influence the choice of demolition method are presented in Table 5.

Table 5 - Factors influencing the choice of the demolition method (Kasai, 1998)

Factor	Description
--------	-------------

Structural form of the building	Shape of the structure as well as technology and materials used
Scale of construction	Larger structures may make a complex method more economic and faster, while small buildings could be demolished using simple techniques
Location of the building	Urban/non-urban settings and access can affect the choice of demolition equipment
Acceptable levels of nuisance	Noise, dust and vibration tolerance levels
Scope of the demolition	Some methods are not suitable for deconstruction or partial demolition
Use of the building	Contaminated structures are treated differently from ordinary structures
Safety	Safety of workers, the public and environment must be ensured with the choice of proper equipment
Time period	Longer periods result in more material separation and reuse, yet short periods may mean a rapid, but not necessarily greater, return of investment

The wide range of demolition techniques and concrete removal methods may be divided into manual labour, mechanical methods, thermal cutting methods, mechanical cutting and grinding methods and expansion-based methods.

Manual labour-based demolition was often used after the First and Second World Wars in heavily bombarded areas. It is still used in countries, where labour is cheaper than the cost of buying or renting demolition equipment. Mechanical demolition methods are normally associated with the heavy demolition of large facilities. These machines may use impact, crushing or shear-based methods to demolish a structure. Table 7 presents some of the heavy demolition equipment used for collecting CDW.

Table 6 presents the various hand-operated tools used for demolition.

Mechanical demolition methods are normally associated with the heavy demolition of large facilities. These machines may use impact, crushing or shear-based methods to demolish a structure. Table 7 presents some of the heavy demolition equipment used for collecting CDW.

Table 6 - Hand-operated demolition tools (Lamond et al., 2002)

	Hand tools	Hammers, chisels, drills, crowbars, sledgehammers, etc., may be used for removing materials in small amounts
Hand operated power tools	Manual electrical tools	These are the smallest type of hand-operated power tools; they have lower energy output, and are mostly used in confined areas
	Manual hydraulic tools	Small impact hammers, drills, saws, and grinders, whose power is provided by small, lightweight power packs
	Manual pneumatic tools	Pavement breakers and jackhammers are available in a wide range of sizes, and are powered by compressed air
	Drop hammers/blades	Available in several sizes and faster than hand-operated pavement breakers, these tools are used to demolish concrete highway pavements, parking lots and other slabs. They produce very little dust, only require one

operator, and are easily handled

Petrol-driven tools Two types: drilling and percussive; or percussive only. Gasoline-powered tools are ideal for remote locations

Table 7 - Heavy demolition equipment (Hendriks and Pietersen, 2000; Lamond et al., 2002)

Heavy demolition equipment	Impact breakers and hammers	Powered hydraulically or by compressed air. These are very common in the demolition industry. Their advantages are their wide range of sizes and ready availability. Both pneumatic and hydraulic breakers can be used for underwater work
	Spring-action hammers	Also known as mechanical sledgehammers, they are used to break concrete pavements, decks, walls, and other thin members. The arm of the hammer is hydraulically powered and the impact head is spring-powered. Much faster than impact hammers
	Wrecking ball	Attached to a crane, the wrecking ball is either dropped or swung against the structure. These come in a wide range of weights that vary according to the crane's capacity
	Mechanical splitters	Using a slitting action developed by a steel plug or wedge, this equipment is placed on pre-drilled holes, in the retracted position. Hydraulic pressure applied to the piston plug advances it, and the feathers are forced against the sides of the hole, producing a break
	Ripper	The ripper is a large blade that is used to break up large areas of slabs and to separate the steel reinforcements from concrete
	Concrete crushers	Concrete crushers have a wide range of sizes and cutting jaw configurations. Ideal for removing kerbs, parapets, slabs, beams and wall sections, and for crushing large pieces of concrete

For thermal cutting operations, the object may be divided into smaller parts by creating narrow slots. Iron and steel are cut by heating them to high temperatures to initiate combustion and then maintaining it. Another common method is melting the material. For mechanical cutting and grinding, a structure is divided into smaller elements using drills and saws listed in Table 9. Some of these apparatuses use hard cutting diamond tools, which can create smooth holes or surfaces. These tools have minimal vibration and, when water-cooled, minimize dust. However, hard aggregates or high concentrations of steel reinforcements can greatly reduce the cutting speed and life of drill bits or saws.

Table 8 presents some thermal cutting equipment.

For mechanical cutting and grinding, a structure is divided into smaller elements using drills and saws listed in Table 9. Some of these apparatuses use hard cutting diamond tools, which can create smooth holes or surfaces. These tools have minimal vibration and, when water-cooled, minimize dust. However, hard aggregates or high concentrations of steel reinforcements can greatly reduce the cutting speed and life of drill bits or saws.

Table 8 - Thermal cutting equipment (Hendriks and Pietersen, 2000)

Thermal cutting equipment	Cutting torch	These tools work on oxygen and fuel gas. The gases are obtained from high-pressure cylinders. The choice of gas and burner depend on the thickness of the material (iron and steel). Once the iron is heated, it will burn in the oxygen flow
	Powder cutting torch	Supplied with iron or aluminium powder, or a mixture of both. These torches have three intakes: oxygen, fuel gas and pressurized air. They cut slots rather than holes and are used for heat resistant steels and cast iron
	Powder cutting lance	Similar to power cutting torches. This unit has connections for oxygen and the powdered air mixture. They are used for steel and other metals, mass concrete and reinforced concrete and other stony materials
	Plasma cutting torch	It can be used to cut highly alloyed and structural steel, aluminium and copper. Plasma is an electrically conductive gas. Unlike in oxygen and fuel gas cutting, the material does not burn; instead, the molten metal is blown out of the cut
	Electrical heating	This method is used to separate concrete from around its steel reinforcements. Cracks develop in the concrete cover, thus facilitating its removal

Table 9 - Mechanical cutting and grinding equipment (Lamond et al., 2002)

Mechanical cutting and grinding equipment	Core drills	Available in various sizes, core drills can be powered by electricity, compressed air, petrol or hydraulic power packs
	Diamond saws	This is the most common type of saw blade for cutting concrete. Dry-cutting diamond blades and abrasive blades are also available. They are used for cutting slabs, pavements and walls
	Hand-held diamond saws	Hand-held diamond saws are generally available in a wide range of diameters and are powered by electricity, petrol engines, compressed air or hydraulic power packs. They are lightweight units designed for sporadic sawing
	Walk-behind diamond saws	Two types of walk-behind diamond saws: light duty for small jobs, and heavier models with engines that are more powerful. Very commonly used in demolition
	Rideable pavement saws	Rideable pavement saws provide high productivity with blades up to 760 mm in diameter
	Wall saws	Wall saws make accurate cuts in walls by riding on a track bolted to the concrete. Blade sizes used are in the same range as floor saws. They are powered by a remote source using either compressed air, hydraulics or an electrical system
	Diamond wire saws	A diamond wire saw is a continuous loop of multi-strand wire strung with steel beads bonded with diamond abrasive that is pulled through concrete. This method is ideal for mass concrete and other sections too thick for diamond-tipped circular saws and where noise or vibration may be a problem
	Stitch drilling	Stitch drilling is a technique used to produce cuts in concrete by overlapping drilled holes. Stitch drilling may be used where the required depth of cut is greater than is possible with a diamond saw

Expansion methods are based on the principle that some elements rupture after considerable volume increase, which may occur at varying speeds. Explosives, gases and solid non-explosive agents (Hydro-demolition, or water-jet blasting is typically used in situations where steel reinforcements are intended for reuse (e.g. rehabilitation). This method does not create vibration-related damage and avoids fire risk, normally from thermal demolition methods.

Table 10) may be used for expansion-based demolition. Thereafter, the resulting materials need to be further reduced in size using other equipment.

Hydro-demolition, or water-jet blasting is typically used in situations where steel reinforcements are intended for reuse (e.g. rehabilitation). This method does not create vibration-related damage and

avoids fire risk, normally from thermal demolition methods.

Table 10 - Expansion-based methods (Hendriks and Pietersen, 2000)

Expansion methods	Explosive blasting	There is a wide range of explosives, with specific properties. Depending on the circumstances and the materials to be demolished, explosives with a high or low detonation speed may be used. The use of explosives is effective for the demolition of large amounts of distressed and deteriorated concrete. Blasting operations are carefully controlled by using a range of detonators and placing explosive materials at strategic points. This allows the structure to collapse onto itself in a matter of seconds, with subsequent minimum physical damage to surroundings. Besides building implosions, explosive blasting can also be used for underwater demolition
	Gas expansion	The expansion of liquid CO ₂ into the gas state builds up pressure in a pre-drilled hole in the material to be demolished. An electrically heated filament initiates the evaporation of gas. The resulting pressure breaks the materials, which will then be reduced in size using other methods
	Non-explosive demolition agents	A mixture consisting primarily of calcium oxide and calcium silicate is mixed with water and then poured into predrilled holes. After some time, the mixture expands, thereby exerting sufficient pressure to crack the concrete. The agent should be used in sound concrete to achieve the desired crack propagation

4 Recycling plants

CDW recycling plants are not greatly different from plants that produce crushed NA from other sources. They may use various crushers, screens, transfer equipment, and devices for removing contaminants, with the objective of manufacturing a specific-sized granular material. The degree of processing depends on the initial CDW's level of contamination and their intended future application, such as: surface material, base and sub-base in road construction, general bulk fill, concrete manufacture or hydraulically bound materials (Hansen, 1992).

4.1 Stationary or mobile?

Recycling plants can be mobile or stationary. Normally, a mobile plant consists of one crusher (very occasionally it may consist of two crushers) and some sorting devices, with lower contamination removal effectiveness (Figure 5). A stationary recycling plant usually consists of a large primary crusher working in conjunction with a secondary or tertiary crusher. They also include various cleaning and sieving devices to produce high quality RA. The choice as to whether CDW processing should be done in stationary or mobile recycling plants is complex and needs to be evaluated on a case-to-case basis taking into account several technical, financial, and environmental aspects (i.e. plant capacity, transportation cost, haulage distances, CDW amount, economy of scale, NA price, and tipping fees)

(Zhao et al., 2010).

Table 11 briefly presents the main advantages and disadvantages of using either of these recycling plants.

The choice as to whether CDW processing should be done in stationary or mobile recycling plants is complex and needs to be evaluated on a case-to-case basis taking into account several technical, financial, and environmental aspects (i.e. plant capacity, transportation cost, haulage distances, CDW amount, economy of scale, NA price, and tipping fees) (Zhao et al., 2010).

Table 11 - Advantages and disadvantages of using mobile or stationary recycling plants

Recycling plant type	Mobile recycling plant	Stationary recycling plant
Advantages	Reduced transportation distances	Production of high quality RA
	Local supply of aggregates increases	Enhanced efficiency in varying particle size distribution
	Easy mobility to another demolition site	Greater manufacturing capacity
Disadvantages	Production of RA of lower quality	High initial investment
	High levels of dust and noise to the vicinity	Greater transportation distances
	Only economically viable when there is sufficient CDW on site	Production efficiency depends on constant CDW supply

Owing to their varying nature, CDW are difficult to process and the existence of contaminants affects the handling and properties of the final product, the quality of which, being inferior to that of NA, is one of the biggest barriers to their wider use in construction. As shown in the literature (Dhir et al., 1999; Dosho et al., 1998; Eguchi et al., 2007; Gokce et al., 2011; Mas et al., 2012; Müller, 2004; Nagataki et al., 2004; Teranishi et al., 1998; Yanagi et al., 1998; Zhao et al., 2010), the treatment procedure considerably affects the quality of RA and, because of the number of existing processing techniques, the characteristics of RA produced in different plants differ significantly. Moreover, materials from the same plant can show changing characteristics, depending on the composition of the demolished source-structure. Nevertheless, stationary recycling plants have progressed to a point that minimizes the quantity of contaminants to an acceptable minimum thereby allowing the production of high quality RA for higher grade applications. This stricter quality control system, normally follows a standard proce-

cedure for acceptance and processing, from their source to the buyer's ownership (Figure 6). Furthermore, owing to their larger size and similar operation to that of conventional aggregate quarries, stationary plants have the potential of building up stocks of different quality materials for immediate supply to larger contracts.

Mobile recycling plants, on the other hand, have a considerable advantage over stationary facilities in terms of the short transportation distances between the demolition site and the processing equipment. Furthermore, when the end use application has low requirements and there is an abundance of inert materials on the demolition site, it is better to use a mobile facility thereby reducing transportation costs and carbon emissions.

Concerning the economic feasibility of CDW recycling plants, Zhao et al. (2010) assessed this feature for a case study in Chongqing, China and observed that there is an enormous demand for recycled materials derived of on-going construction activities, which created a large market potential and thus a significant growth of the recycling sector. The authors concluded that recycling plants with new equipment have uncertain viability because the profit margin is limited by high fixed costs. However, the economic feasibility of recycling plants is improved if production costs can be lowered by taking advantage of the economies of scale of stationary plants; as the size of the recycling plant increases, the production costs of RA decrease, as fixed costs are amortized due to the greater production. Operational efficiency also improves with increasing scale, leading to lower variable costs.

More recently, Coelho and de Brito (2013a, b) analysed the economic viability of a CDW recycling plant in Portugal, the conclusions of which further reinforced some of those of the abovementioned study. The most favourable conditions were when the gate fees were at their highest and nearly all of the delivered CDW materials were completely mixed. These two parameters maximized the plant's financial feasibility from charging the highest CDW input gate fee. Therefore, special attention must be given to ensure that this fee is managed as efficiently as possible, since it has a strong influence on the facility's profitability.

4.2 Recycling procedure

There is a wide range of possible recycling procedures, which can change according to the level of contamination, available technology and the products' desired quality. Figure 7 shows a flow diagram of a possible combination of recycling processes that can produce RA of relatively good quality and with minimum contamination, without spending too much energy. In the case of plain concrete blocks (without steel reinforcements), for example, it is possible to bypass some of the processes such as manual or mechanical removal of contaminants, thus saving energy.

4.2.1 Crushing stage

Upon arrival at the recycling plant, CDW may either enter directly into the processing operation or need to be broken down to obtain materials with workable particle sizes, in which case hydraulic breakers mounted on tracked or wheeled excavators are used. In either case, manual sorting of large pieces of steel, wood, plastics and paper may be required, to minimize the degree of contamination.

The three types of crushers most used for crushing CDW are jaw, impact, and gyratory crushers (Figure 8). A jaw crusher consists of two plates fixed at an angle (Figure 8a); one plate remains stationary while the other oscillates back and forth relative to it, crushing the material passing between them. This crusher can withstand large pieces of reinforced concrete, which would probably cause other types of crushers to break down. Therefore, the material is initially reduced in jaw crushers before going through other types. The particle size reduction depends on the maximum and minimum size of the gap at the plates. Jaw crushers were found to produce RA with the most suitable grain-size distribution for concrete production (Molin et al., 2004).

An impact crusher breaks CDW by striking them with a high speed rotating impact, which imparts a shearing force on the debris (Figure 8b). Materials fall onto the rotor and are caught by teeth or hard steel blades fastened to the rotor, which hurl them against the breaker plate, smashing them to smaller-sized particles. Impact crushers provide better grain-size distribution of RA for road construction pur-

poses and are less sensitive to material that cannot be crushed (i.e. steel reinforcement).

Gyratory crushers, which work on the same principle as cone crushers (Figure 8c), exhibit a gyratory motion driven by an eccentric wheel and will not accept materials with large particle sizes as they are likely to become jammed. However, gyratory and cone crushers have advantages such as relatively low energy consumption, reasonable amount of control over particle size and production of low amount of fine particles.

Generally, jaw and impact crushers have a large reduction factor, defined as the relationship between the input's particle size and that of the output. A jaw crusher crushes only a small proportion of the original aggregate particles but an impact crusher crushes mortar and aggregate particles alike, and thus may generate twice the amount of fines for the same maximum size of particle (O'Mahony, 1990).

In order to produce RA with predictable grading curve, it is better to process debris in two crushing stages, at least. It may be possible to consider a tertiary crushing stage and further, which would undoubtedly produce better quality coarse RA (i.e. less adhered mortar and with a rounder shape). However, concrete produced with RA subjected to a tertiary crushing stage may show only slightly better performance than that made with RA from a secondary crushing stage (Gokce et al., 2011; Nagataki et al., 2004). Furthermore, more crushing stages would yield products with decreasing particle sizes, which contradicts the mainstream use of RA (i.e. coarser RA fractions are preferred, regardless of the application). These factors should be taken into account when producing RA as, from an economical and environmental point of view, it means that relatively good quality materials can be produced with lower energy consumption and with a higher proportion of coarse aggregates, if the number of crushing stages is prudently reduced.

4.2.2 Sorting and contamination removal

There are two attitudes towards the removal of contaminants from CDW: pre-crushing separation or post crushing separation (O'Mahony, 1990). In the first approach, debris can be sorted while a struc-

ture is being demolished. Although this type of separation can be expensive and time-consuming for the demolition contractor, it brings great benefits later on, both ecological and financial. Sorting can also take place when CDW reach the recycling plant. Once there, these are stockpiled according to major constituents and/or the expanse of contamination thereby allowing the plant operator to take the necessary measures for each case. This initial sorting can help optimize the crushing time, energy spent and quality of the product, e.g. if large quantities of clean debris have accumulated in a stockpile, they can then be crushed in a single, continuous run.

It is also possible that, if CDW introduced in the recycling process have a small enough particle size and with no need for further crushing (as exemplified in Figure 7), then the primary crusher is bypassed. Furthermore, should these also be concrete-based and exhibit a very low degree of contamination, it is possible to make good use of the material finer than 10 mm in the primary screening stage, instead of disposing of it. Many studies have shown that the use of fine RA is perfectly feasible in the production of mortars (Ledesma et al., 2015; Silva et al., 2016c) and structural concrete (Evangelista and de Brito, 2004; Evangelista and de Brito, 2007, 2014; Evangelista et al., 2015), provided that a strict quality control is followed during the mixing procedure.

Post-crushing separation, on the other hand, is carried out after crushing stages, where several contaminant removal techniques may be employed. The most straightforward method is hand sorting, which involves removing contaminants by hand from the conveyor belts. Concentration of operators and speed of the conveyor belt are vital factors for the efficiency of the hand sorting system. Although the human eye can recognise contaminants that would be difficult to remove by mechanical means (e.g. glass, asphalt), it is also the costlier approach.

After the primary crushing stage, self-cleaning magnets, positioned in various strategic locations over the conveyor belts, separate bits of steel reinforcements and other ferromagnetic metals. Their efficiency depends on the distance between the magnet and the debris, the conveyor belt speed, the volume of passing debris and the angle of the magnet. A magnet is more efficient when it is posi-

tioned directly above and parallel to a slow moving conveyor belt with a low concentration of material. Electromagnets may be in a fixed position above the conveyor belt (Figure 9a) or take the form of a rotating magnetic belt (Figure 9b). The magnetic belt has the advantage of carrying the metals to the side, instead of accumulating them in the magnet.

In addition to ferrous metals, CDW may contain non-ferrous metals such as aluminium, copper, brass, lead and zinc. These are non-magnetic and thus have to be separated from CDW using an eddy current separator, which is based on the principle that when a conducting metal is led through a varying magnetic field, eddy currents are generated in the metal. By placing this device at the end of a conveyor belt, metals are thrown off the belt, while other materials simply fall off, due to gravity. Since ferromagnetic metals may damage the eddy current separator, these must be removed from the debris at an earlier stage.

At a later stage, it is possible to eliminate dirt, gypsum, plaster, and other fine impurities by passing the crushed aggregates over a set of scalping screens. Dry screening can be used to separate the material into several size fractions, which can later be recombined to produce well-graded RA. Materials can be separated more efficiently by using sloped screens vibrating at low frequencies and large amplitudes, while horizontal screens vibrating at high frequencies and small amplitudes are better for separating fine material. This process only separates material based on particle size and shape.

Concerning the final contamination removal stages, either air sifting or wet separation can be used. Although air sifting may be as effective as wet separation, in terms of the removal of lightweight contaminants (i.e. wood, hardboard, plastics, straw, roofing felt, and asbestos fibres), and would also avoid the use of large quantities of water, the latter allows leaching of water-soluble chlorides and sulphates (Galvin et al., 2014; Rodrigues et al., 2013; Van Der Wegen and Haverkort, 1998; Weimann and Müller, 2004). Despite the potentially lower economic and ecological advantages, this means that aggregate washing is a better contaminant removal method for the production of RA meant for the production of cementitious materials, than air sifting. However, since sulphate or

chloride contents have little impact on the performance of unbound or bitumen bound applications, the air sifting method can be used instead of wet separation.

As a complement to the aforementioned crushing procedures, there are also other less conventional methods for the removal of adhered cement mortar from the surface of the original natural aggregates. Table 12 presents a brief description to each of these methods.

Table 12 - Alternative contamination removal methods for old adhered mortar

Method	Description	References
Underwater high performance sonic impulses	<ul style="list-style-type: none"> Electrical energy is transformed into mechanical energy in the form of sonic impulses generated underwater, which are applied to RCA in a water-filled container The sonic waves generate pressure and tensile stresses between aggregate and old cement mortar, destroying their bond The particle size reduces and the adhered cement paste separates from the aggregates Quality and particle size of the end product can be controlled by varying the number of impulses and voltage 	(Linß and Mueller, 2004) (Maeda et al., 2008) (Narahara et al., 2007)
Microwave heating	<ul style="list-style-type: none"> Exposure of RCA to concentrated microwave heating at relatively high frequencies, high temperatures develop in the surface layer while the interior temperature remains more or less unaffected This differential heating leads to high thermal stresses as well as rapid evaporation of any water inside the aggregates and causes the delamination of adhered cement mortar By adjusting the microwave frequency and power, it is possible to control the extent and pattern of the microwave heating 	(Akbarnezhad and Ong, 2010) (Akbarnezhad et al., 2011) (Ong et al., 2009) (Ong et al., 2010)
Wet grinding method	<ul style="list-style-type: none"> In the wet grinding method, concrete is ground by the rotation of a rotor positioned inside a cylindrical shell Fine RA, of 5 mm or less, are produced by passing through a screen and contaminants (i.e. fine powder, wood chips) are extracted by a wet high-speed centrifuge 	(Dosho, 2007)
Heating and grinding method	<ul style="list-style-type: none"> The differential heating of RCA to around 300 °C “softens” the adhered cement mortar by producing micro-cracks in the ITZ between the cement mortar and the original NA After thermal processing, RCA are subjected to a grinding process that separates the adhered cement mortar from the original NA, since the bond between them has been weakened, resulting in a relatively clean aggregate 	(Shima et al., 2005)
Screw grinding method	<ul style="list-style-type: none"> Shaft screw with an intermediate part, followed by an exhaust part with a warping cone, which removes the adhered cement mortar 	(Matumura, 2005)
Mechanical grinding method	<ul style="list-style-type: none"> In a drum body, steel balls move vertically and horizontally by rolling the drum, which separates partition boards with holes of the same size The quality of the end product can be adjusted by narrowing the inside space using the partition boards 	(Kajima, 2006)

4.3 Storage of CDW before and after processing

Experience has shown that the system, currently practiced by many construction and demolition operators and in recycling facilities, lacks proper categorisation and storing of materials, which normally leads to severe contamination and increases gate fees and processing costs. Several aspects must be taken into account when handling CDW (Shukla et al., 2000):

- At an initial stage, all CDW should be stored onsite, within suitable containers so that the

waste does not get scattered and does not become an eyesore to the public;

- Wastes must be properly separated into different heaps to preserve their characteristics, thus facilitating their future reuse or recycling;
- Materials that can be reused at the same site (e.g. levelling, base layers, road surface pavement) should be kept in separate heaps from others that will be sold or sent to landfill;
- In large projects (e.g. bridges, dams), special considerations must be made for storage of waste. Movement of CDW has to be planned according to the site's storage capacity, otherwise, sending it to recycling plants or landfill would place a constraint on the job and be a nuisance to road traffic.

Naturally, care must also be taken when storing RA after beneficiation, in order to prevent mixing and/or contamination. The following recommendations must be followed whenever possible (Kasai, 1998):

- RA derived from materials of different quality shall be stored separately;
- RA produced by different recycling procedures methods shall be stored separately;
- RA of different types shall be stored separately;
- RA with different size fractions shall be stored separately;
- Due to the self-cementing properties of unhydrated cement particles within RA, it is recommended that materials are kept dry, as long as possible, until their use;
- RA shall be transported in a manner that respects the above recommendations and that prevents breakage and segregation;
- It is recommended that each set of mechanisms in a recycling plant should only process CDW of given quality and type as this will both reduce cleaning expenses and the risk of contamination when switching from one material to another.

5 Certification of recycled aggregates

Two categories of marketable aggregates are currently produced: non-certified and certified aggregates (Trevorrow and Lyne, 1998). Non-certified aggregates currently comprise the majority of the output of recycling plants. However, due to stricter demands from consumers who are searching for RA of a guaranteed and specifiable quality, certification is of the utmost importance.

Certification guarantees the quality of the aggregate, meets recognized standards and is within audited quality assurance schemes. Certified RA conform to the same specifications as those of traditional NA and may be sourced from dedicated aggregate producers and mobile waste transformation producers. Factors affecting the production and use of certified RA are described in **Error! Not a valid bookmark self-reference.** The factors are interrelated and form a development cycle, which must be refined by each of the RA producers by focusing on different areas of the cycle.

Ideally, dedicated RA producers/suppliers should produce materials of the highest specification. This means they can also make room for retailing RA with a wider range of specified quality for several designated applications. However, in reality, many recycling plants tend to produce material of lower specification, in spite of the potentially high quality input, because of inadequate quality control. In many of these situations, premium gate fees are also paid upon acceptance of highly mixed CDW and the extra processing costs involved in producing certified high quality RA are deemed unjustified due to the small increase in revenue. Furthermore, the mixed source of the waste also means that the end product is not uniform, making it harder to guarantee consistent specification.

Table 13 - Description of factors affecting the production and use of certified RA (Trevorrow and Lyne, 1998)

Price	<ul style="list-style-type: none"> • Certified RA are cheaper than identically certified NA • Price differential set to widen with increasing taxation - greater incentive for maximization of waste utility
Legislation	<ul style="list-style-type: none"> • Increasingly green business conscience created by government legislation • Increasing landfill tax and possible natural aggregate tax
Perception	<ul style="list-style-type: none"> • Greater acceptance, due to less perception of lack of quality, encouraged by certification and standards • Increasing market need, due to dwindling natural resources' reserves, combined with evolving successful usage record

Processing technology	<ul style="list-style-type: none"> • Recycling facilities need to respond to greater market demand by improving quality of processing, increasing product ranges and specifications • Higher RA market selling price increases confidence for supplier's capital expenditure
Geographic location	<ul style="list-style-type: none"> • Developing markets utilize geographically available recycled waste products.
Utilization	<ul style="list-style-type: none"> • Greater emphasis on maximizing waste utilization • Increasing importance of selective demolition techniques to facilitate future waste utilization
Information	<ul style="list-style-type: none"> • Increasing coordinated access to market information
Quality	<ul style="list-style-type: none"> • "Fit for purpose" criteria to avoid over-specification of materials • Increasing market acceptance through extended certification • Quality production within audited quality systems

Assuming that proper beneficiation procedures would be used, yet with low quality control during construction or demolition operations, it is likely that these initially poorly screened materials would exhibit relatively low quality at the end of the recycling procedure. Still, despite the potential inconsistency of the final product, this should not hinder the certification of RA, since the most intrinsic physical properties will remain thereby allowing proper categorization.

Indeed, in a previous study (Silva et al., 2014b) the authors observed that the basic physical properties of RA followed a predictable relationship, regardless of their size and composition, which allowed the development of a performance-based classification system that is easily understandable by all professionals in the industry. Thereon, using this classification on the mechanical, durability and structural behaviour of RAC (Silva et al., 2014a; 2016a; 2016b; 2015a; 2015b), high correlations have been systematically observed thereby allowing accurate prediction of the materials' performance. Therefore, in view of these results, it became clear that, not only can this classification be easily implemented, but it can also show high reliability and reproducibility of results and thus facilitate certification of the final product.

6 Recommendations for industry-guiding research

Despite the vast research on the subject and of the technical feasibility of construction materials containing RA, these should be restricted to applications where successful research has already been carried out. Several gaps have been identified in the literature (de Brito and Silva, 2016), which still

need to be addressed before using RA in more demanding applications, with special emphasis towards structural RAC, namely:

- **Quality control increase throughout the material's life cycle** - It is possible to predict how the RA's quality will affect the performance of resulting recycled materials, as demonstrated in recent developments (Silva et al., 2014b). However, it is crucial that the RA's contamination level is minimized throughout the recycling process (including construction and demolition activities), in order to produce a certifiable, fit-for-purpose high-quality material. Furthermore, a new treatment approach (storing RCA in a CO₂-enriched environment) capable of improving the physical properties of RCA has been gaining attention, which also enhances the performance of the resulting RAC (Tam et al., 2016). This treatment, which occurs after the processing techniques in section 4.2, is capable of sequestering CO₂ captured from other industrial operations. Still, since CO₂-treated RCA may compromise the steel reinforcement's passive layer (Zhan et al., 2014), more research is required to ascertain both technical and economic viability of using such approach;
- **Deformation over time of structural RAC** - Despite the amount of studies concerning the rheological behaviour of RAC, the few existing studies on creep suggest considerable deformation increase. Even though creep deformation can be readily calculated using recent prediction models (Silva et al., 2015c), research that can produce more accurate correction factors is further needed thereby ensuring their integration in structural codes;
- **Performance-based structural design** - In view of the viability of producing construction materials containing RA, some authors assessed the material's macrostructural performance and ways of optimizing its incorporation (Senaratne et al., 2016; Tam et al., 2016). In comparison to conventional reinforced concrete, structural RAC generally exhibits equivalent rupture mechanisms and any decrease in structural performance (especially deflection) correlates to the material's mechanical performance decline. In order to increase the wider use of RA in

structural applications, the following subjects still need to be further explored to bring about essential amendments to structural codes: pre-stressed concrete, shear strength, load redistribution, fatigue, long-term deflection and punching shear;

- **“Cradle-to-cradle” life cycle assessments (LCA) and costs (LCC)** - Calculation of the global cost of producing a recycled material of equivalent performance to that of a conventional one is complex and depends on several factors, which have to be constantly updated with new findings. It is known that the advantages/disadvantages of using RA-containing materials, from environment and economic viewpoints, heavily depend on road haulage distances (Coelho and de Brito, 2013a, b). However, in view of the recent encouraging results of applying a selective demolition approach (Coelho and de Brito, 2011), this factor must be considered in future assessments, as well as NA and landfill taxation, and other currently practiced fees, in order to allow more comprehensive LCA (Estanqueiro et al., 2016) and LCC from a complete life cycle perspective.

7 Conclusions

From the study of the various aspects related to existing barriers to RA reuse and recycling, economic benefits, environmental impacts, and the proper demolition approach and equipment to achieve certification of RA, the following conclusions were drawn from the results obtained in the literature:

- Even though several obstacles to the use of RA have been identified, most of them can be overcome by: proactive engagement of construction and demolition industries, presenting RA as a technically feasible and economically viable alternative to their natural counterparts, rising of landfill taxation, NA levies, and gate fees for improperly sorted CDW, enforcing greater control over illegal dumping operations;
- Since most construction and demolition activities are performed by small and medium enter-

prises, it is vital that they are controlled by an external entity when engaged in these activities. Apart from encouraging contractors to use a selective demolition approach, which adds value to CDW, that entity would also assess its best possible use or destination;

- Even though the results of economic viability assessments of implementing a recycling system showed considerable revenues, these depend on a number of factors inherent to each region and thus cannot be extrapolated. However, the key lesson acquired from them is that the recycling approach is significantly more beneficial than conventional demolition and disposal methods, both from an environmental and economic perspective;
- Of two distinct methodologies for the demolition of building structures, the selective demolition approach is by far the most effective method to achieve sustainability in construction and demolition-related activities and must be enforced whenever possible;
- Recycling is most effective when it is driven by the client and is considered from the start of the project. Early involvement of all key players in the supply chain will yield the most economic and environmental benefits. Also, early-applied quality control, by means of a more suitable separation and subsequent storage of CDW, is vital to achieve the highest possible quality in RA thereby increasing potential for reuse in new construction;
- Given the varying composition of CDW, it must be analysed during construction and demolition activities in order to minimize contamination and thus increase the value of the final material. Assessment of the contents of CDW must also be performed upon delivery to the recycling facility so as to determine the most effective procedure to maximize the output's quality. Furthermore, this will reduce processing time, produce higher quality RA, increase the work rate and help avoid excessive costs incurred by unnecessary recycling stages;
- Further crushing stages will decrease roughness, irregularity, and the amount of adhered mortar and thus increase the quality of the resulting coarse RA. However, given the minimal improvements prompted by the use of a tertiary crushing stage, its implementation must be pon-

dered on a case-by-case basis, as it will only slightly improve the quality of RA, decrease the coarse to fine RA ratio, and increase costs and energy spent;

- Effective quality control and certification of RA by suppliers are essential to instigate and sustain high stakeholder confidence in the materials. However, this must be backed by greater governmental intervention in the form of robust legislation and standardization;
- Classifying RA based on their performance, apart from presenting itself as a more practical approach, owing to its easy adaptability and simplicity in a way that can be applied by all individuals in the construction industry, has demonstrated strong correlations to the concrete's performance. Furthermore, this categorization into different classes, with ensuing certification, allows producing a wide range of materials of recognized quality that can then be applied in a broadened scope of construction applications and thus be capable of responding to the demand of individuals with specific requirements.

References

- ACI-318, 2014. Building code requirements for structural concrete (ACI 318-14) and commentary. American Concrete Institute - ACI Committee 318, Farmington Hills, Michigan, USA.
- ACWMA, 2013. Building 802 deconstruction project - Deconstruction results report: Oakland: Alameda County Waste Management Authority. Available at www.stopwaste.org (accessed in October 2013).
- Akbarnezhad, A., Ong, K.C.G., 2010. Microwave decontamination of concrete. *Mag. Concr. Res.* 62(12), 879-885.
- Akbarnezhad, A., Ong, K.C.G., Zhang, M.H., Tam, C.T., Foo, T.W.J., 2011. Microwave-assisted beneficiation of recycled concrete aggregates. *Constr. Build. Mater.* 25(8), 3469-3479.
- Bartelingsa, H., Linderhofb, V., 2006. Effective landfill taxation: A case study for the Netherlands, ECOMOD 2006, Hong Kong, pp. 1-25.

- Blengini, G.A., Garbarino, E., 2010. Resources and waste management in Turin (Italy): the role of recycled aggregates in the sustainable supply mix. *J. Cleaner Prod.* 18(10–11), 1021-1030.
- Bond, D., 2005. Technical and cost benefits of recycled and secondary aggregates: Supply chain case studies (Infrastructure), DTI/WRAP Aggregates Research Programme STBF 13/09C, 54 p.
- Bravo, M., de Brito, J., Pontes, J., Evangelista, L., 2015. Mechanical performance of concrete made with aggregates from construction and demolition waste recycling plants. *J. Cleaner Prod.* 99, 59-74.
- BRE, 1998. Recycled aggregates, BRE Digest 433, CI/SfB p(T6). Building Research Establishment, Watford, UK, 6 p.
- BRE, 2008. Sustainable Construction - Simple ways to make it happen. Building Research Establishment, Environmental Consultancy, IHE BRE Press, ISBN 978-1-84806-049-4, Watford, UK, 20 p.
- CIB, 2003. Deconstruction and materials reuse. In: Chini, A.R. (Ed.), CIB Report. CIB - International Council for Research and Innovation in Building Construction, Florida, USA, 420 p.
- Coelho, A., de Brito, J., 2011. Economic analysis of conventional versus selective demolition-A case study. *Resour. Conserv. Recy.* 55(3), 382-392.
- Coelho, A., de Brito, J., 2012. Influence of construction and demolition waste management on the environmental impact of buildings. *Waste Manage. (Oxford)* 32(3), 532-541.
- Coelho, A., de Brito, J., 2013a. Economic viability analysis of a construction and demolition waste recycling plant in Portugal - part I: location, materials, technology and economic analysis. *J. Cleaner Prod.* 39, 338-352.
- Coelho, A., de Brito, J., 2013b. Economic viability analysis of a construction and demolition waste recycling plant in Portugal - part II: economic sensitivity analysis. *J. Cleaner Prod.* 39, 329-337.
- Coelho, A., de Brito, J., 2013c. Environmental analysis of a construction and demolition waste recycling plant in Portugal - Part I: Energy consumption and CO₂ emissions. *Waste Manage. (Oxford)* 33(5), 1258-1267.

- Coelho, A., de Brito, J., 2013d. Environmental analysis of a construction and demolition waste recycling plant in Portugal - Part II: Environmental sensitivity analysis. *Waste Manage. (Oxford)* 33(1), 147-161.
- Crushersale, 2013. Illustrated example of a cone crusher. Available at <http://crushersale.com> (accessed July 2013).
- CRWP, 2007. BigREc Survey: A survey of the UK reclamation and salvage trade. Construction Resources and Waste Platform, 28 p.
- DAfStb, 1998. DAfStb: Richtlinie - Beton mit rezykliertem zuschlag (in German). Deutscher Ausschuss Für Stahlbeton (German Committee for Reinforced Concrete), Berlin, Germany.
- Dantata, N., Touran, A., Wang, J., 2005. An analysis of cost and duration for deconstruction and demolition of residential buildings in Massachusetts. *Resour. Conserv. Recy.* 44(1), 1-15.
- De Brito, J., Silva, R.V., 2016. Current status on the use of recycled aggregates in concrete: Where do we go from here? *RILEM Technical Letters* 1, 1-5.
- De Vries, P., 1995. Recycled materials for concrete: A report on the Dutch experience. *Quarry Management* 22(12), 23-26.
- DETR, 2000. Controlling the environmental effects of recycled and secondary aggregates production - Good practice guidance, Rotherham, UK, DETR, 143 p.
- Dhir, R.K., Dyer, T.D., Paine, K.A., 2004. Dismantling barriers: Roles for research in realising markets for construction and demolition wastes, 1st International Conference on Sustainable Construction: Waste Management. CPG Laboratories Pte Ltd, Singapore, pp. 1-22.
- Dhir, R.K., Limbachiya, M.C., Leelawat, T., 1999. Suitability of recycled concrete aggregate for use in BS 5328 designated mixes. *Proceedings of the Institution of Civil Engineers - Structures and Buildings* 134(3), 257-274.
- Dosho, Y., 2007. Development of a sustainable concrete waste recycling system - Application of recycled aggregate concrete produced by aggregate replacing method. *J. Adv. Concr. Technol.* 5(1), 27-

42.

Dosho, Y., Narikawa, M., Nakagome, A., Kikuchi, M., 1998. Application of recycled aggregate concrete for structural concrete. Part 2 - Feasibility study on cost effectiveness and environmental impact, in: Dhir, R.K., Henderson, N.A., Limbachiya, M.C. (Eds.), Proceedings of the International Conference on the Use of Recycled Concrete Aggregates. Thomas Telford, London, UK, pp. 389-400.

EEA, 2009. Diverting waste from landfill: Effectiveness of waste management policies in the European Union European Environmental Agency, Copenhagen, Denmark, 68 p.

Eguchi, K., Teranishi, K., Nakagome, A., Kishimoto, H., Shinozaki, K., Narikawa, M., 2007. Application of recycled coarse aggregate by mixture to concrete construction. *Constr. Build. Mater.* 21(7), 1542-1551.

EHE-08, 2010. Code on Structural Concrete. Publication Center, General Technical Secretariat, Ministry of Development, Madrid, Spain, 556 p..

EN-1992-1-1, 2008. Eurocode 2 - Design of concrete structures: Part 1-1: General rules and rules for buildings. Comité Européen de Normalisation (CEN), Brussels, Belgium, 259 p.

Eurostat, 2015. Waste statistics in Europe. Available at epp.eurostat.ec.europa.eu (accessed March 2015).

Estanqueiro, B., Silvestre, J., de Brito, J., 2007. Environmental Life Cycle Assessment of coarse natural and recycled aggregates for concrete. *Eur. J. Enviro. Civ. Eng.* DOI:10.1080/19648189.2016.1197161.

Evangelista, L., De Brito, J., 2004. Criteria for the use of fine recycled concrete aggregates in concrete production, in: Vázquez, E., Hendriks, C., Janssen, G.M.T. (Eds.), International RILEM Conference on the Use of Recycled Materials in Buildings and Structures. RILEM Publications SARL, Barcelona, Spain, pp. 503-510.

Evangelista, L., de Brito, J., 2007. Mechanical behaviour of concrete made with fine recycled concrete aggregates. *Cem. Concr. Compos.* 29(5), 397-401.

Evangelista, L., de Brito, J., 2014. Concrete with fine recycled aggregates: A review. *European Journal*

of Environmental and Civil Engineering 18(2), 129-172.

Evangelista, L., Guedes, M., de Brito, J., Ferro, A.C., Pereira, M.F., 2015. Physical, chemical and mineralogical properties of fine recycled aggregates made from concrete waste. *Constr. Build. Mater.* 86, 178-188.

EPA, 2014. United States Environmental Protection Agency. Available at www.epa.gov (accessed October 2014).

Galvin, A.P., Ayuso, J., Garcia, I., Jimenez, J.R., Gutierrez, F., 2014. The effect of compaction on the leaching and pollutant emission time of recycled aggregates from construction and demolition waste. *J. Cleaner Prod.* 83, 294-304.

Gokce, A., Nagataki, S., Saeki, B., Hisada, M., 2011. Identification of frost-susceptible recycled concrete aggregates for durability of concrete. *Constr. Build. Mater.* 25(5), 2426-2431.

Goncalves, P., de Brito, J., 2010. Recycled aggregate concrete (RAC) - comparative analysis of existing specifications. *Mag. Concr. Res.* 62(5), 339-346.

GOV.UK, 2016. Environmental taxes, reliefs and schemes for businesses. Available at www.gov.uk (accessed September 2016).

Guthrie, P., 1997. Waste minimisation and recycling in construction and demolition - A CIRIA project, Aggregates Advisory Service Seminar, Barbican, London, UK, 7 p.

Guy, B., 2006. The Optimization of Building Deconstruction for Department of Defense Facilities: Ft. McClellan Deconstruction Project. *Journal of Green Building* 1(1), 102-122.

Guy, B., Gibeau, E.M., 2003. A guide to deconstruction. Deconstruction Institute, Florida, USA, 93 p.

Hansen, T.C., 1992. Recycling of Demolished Concrete and Masonry. E & FN Spon, London, UK.

Hendriks, C.F., 1998. Application of aggregates out of construction: and demolition waste in road constructions and concrete, CIB World Building Congress Construction and Environment, Gävle, Sweden, pp. 211-222.

Hendriks, C.F., Pietersen, H.S., 2000. Sustainable Raw Materials - Construction and Demolition Waste,

- State-of-the-Art Report of RILEM Technical Committee. RILEM, 216 p.
- Hurley, J.W., McGrath, C., Fletcher, S.L., Bowes, H.M., 2001. Deconstruction and reuse of construction materials, BRE Report 418. British Research Establishment, London, UK, 33 p.
- Kajima, 2006. Recycled aggregate concrete for within-site recycling. Available at www.kajima.co.jp (accessed July 2013).
- Kasai, Y., 1998. Barriers to the reuse of construction by-products and the use of recycled aggregate in concrete in Japan, in: Dhir, R.K., Henderson, N.A., Limbachiya, M.C. (Eds.), Proceedings of the International Symposium on Sustainable construction: Use of recycled concrete aggregate. Thomas Telford, London, UK, pp. 433-444.
- Kumbhar, S.A., Gupta, A., Desai, D.B., 2013. Recycling and reuse of construction and demolition waste for sustainable development. *OIDA International Journal of Sustainable Development* 6(7), 83-92.
- Lamond, J.F., Campbell, R.L., Giraldi, A., Jenkins, N.J.T., Campbell, T.R., Halczak, W., Miller, R., Cazares, J.A., Hale, H.C., Seabrook, P.T., 2002. Removal and reuse of hardened concrete. *ACI Mater. J.*, 300-325.
- Ledesma, E.F., Jiménez, J.R., Ayuso, J., Fernandez, J.M., de Brito, J., 2015. Maximum feasible use of recycled sand from construction and demolition waste for eco-mortar production - Part-I: ceramic masonry waste. *J. Cleaner Prod.* 87, 692-706.
- Linß, E., Mueller, A., 2004. High-performance sonic impulses - an alternative method for processing of concrete. *Int. J. Miner. Process.* 74, S199-S208.
- Maeda, S., Shigeishi, M., Namihira, T., Ohtsu, M., Akiyama, H., 2008. Recycling technology for concrete aggregate using underwater electric pulse discharge, in: Dhir, R.K., Hewlett, P.C., Csetenyi, L.J. (Eds.), Proceedings of the International Conference on the Role for Concrete in Global Development. IHS BRE Press, University of Dundee, Scotland, UK, pp. 325-336.
- Mas, B., Cladera, A., Olmo, T., Pitarch, F., 2012. Influence of the amount of mixed recycled aggregates on the properties of concrete for non-structural use. *Constr. Build. Mater.* 27(1), 612-622.

- Matumura, U., 2005. Concrete recycling technology, Proceeding of Annual Conference of Consultants, Hokkaido, Japan, pp. 5-10.
- Molin, C., Larsson, K., Arvidsson, H., 2004. Quality of reused crushed concrete strength, contamination and crushing technique, in: Vázquez, E., Hendriks, C., Janssen, G.M.T. (Eds.), International RILEM Conference on the Use of Recycled Materials in Buildings and Structures. RILEM Publications, Barcelona, Spain, pp. 150-155.
- Müller, A., 2004. Lightweight aggregates from masonry rubble, in: Vázquez, E., Hendriks, C., Janssen, G.M.T. (Eds.), International RILEM Conference on the Use of Recycled Materials in Buildings and Structures. RILEM Publications SARL, Barcelona, Spain, pp. 97-106.
- Nagataki, S., Gokce, A., Saeki, T., Hisada, M., 2004. Assessment of recycling process induced damage sensitivity of recycled concrete aggregates. *Cem. Concr. Res.* 34(6), 965-971.
- Narahara, S., Nakashima, T., Nakashima, K., Inoue, S., Iizasa, S., Maeda, S., Shigeishi, M., Ohtsu, M., Akiyama, H., 2007. Evaluation of concrete made from recycled coarse aggregates by pulsed power discharge, 2007 IEEE Pulsed Power Conference, Vols 1-4, pp. 748-751.
- Nordberg, 1994. Illustrated example of fixed electromagnets and rotating magnetic belts.
- O'Mahony, M.M., 1990. Recycling materials in Civil Engineering. New College, University of Oxford, Oxford, UK, 233 p.
- Ong, K.C.G., Anggadajaja, E., Soh, S.L.Y., 2009. Sustainable Construction Strategies: A Singapore Perspective, CMS2009: Conference on Construction Material Stewardship - Lifecycle Design of Buildings, Systems and Materials. in-house publishing, Rotterdam, The Netherlands, pp. 8-13.
- Ong, K.G.C., Akbarnezhad, A., Zhang, M.H., Tam, C.T., Hao, J., Timothy, W.J.F., 2010. Mechanical properties of concrete incorporating microwave-treated recycled concrete aggregates, 35th Conference on Our World In Concrete & Structures. Singapore Concrete Institute, Singapore, 9 p.
- Pedro, D., de Brito, J., Evangelista, L., 2014. Influence of the use of recycled concrete aggregates from different sources on structural concrete. *Constr. Build. Mater.* 71, 141-151.

- Penncrusher, 2013. Illustrated example of a jaw and impact crusher. Available at www.penncrusher.com (accessed July 2013).
- RILEM, 1994. Specifications for concrete with recycled aggregates. *Mater. Struct.* 27(173), 557-559.
- Rodrigues, F., Carvalho, M., Evangelista, L., de Brito, J., 2013. Physical-chemical and mineralogical characterization of fine aggregates from construction and demolition waste recycling plants. *J. Cleaner Prod.* 52, 438-445.
- Roussat, N., Dujet, C., Méhu, J., 2009. Choosing a sustainable demolition waste management strategy using multicriteria decision analysis. *Waste Manage. (Oxford)* 29(1), 12-20.
- Schlauder, R.M., Brickner, R.H., 1993. *Solid Waste & Power*, 28-34.
- Senaratne, S., Gerace, D., Mirza, O., Tam, V.W.Y., Kang, W.-H., 2016. The costs and benefits of combining recycled aggregate with steel fibres as a sustainable, structural material. *J. Cleaner Prod.* 112, Part 4, 2318-2327.
- Shima, H., Tateyashiki, H., Matsushashi, R., Yoshida, Y., 2005. An advanced concrete recycling technology and its applicability assessment by the input-output analysis. *J. Adv. Concr. Technol.* 3(1), 53-67.
- Shukla, S.R., Akolkar, A.B., Bhide, A.D., Dhussa, A.K., Varshney, A.K., Acharya, D.B., Datta, M.M., Dutta, M., Mazumdar, N.B., Asnani, P.U., Ramanathan, R., Ramaprasad, V.B., Uppal, B.B., Dhinadhayan, M., 2000. *Manual on municipal solid waste management*. Ministry of Urban Development - Government of India, New Delhi, India, 663 p.
- Silva, R.V., 2015. Use of recycled aggregates from construction and demolition waste in the production of structural concrete, Department of Civil Engineering, Architecture and Georesources. Instituto Superior Técnico, Lisboa, Portugal.
- Silva, R.V., de Brito, J., Dhir, R.K., 2014a. The influence of the use of recycled aggregates on the compressive strength of concrete: a review. *European Journal of Environmental and Civil Engineering* 19(7), 825-849.

- Silva, R.V., de Brito, J., Dhir, R.K., 2014b. Properties and composition of recycled aggregates from construction and demolition waste suitable for concrete production. *Constr. Build. Mater.* 65, 201-217.
- Silva, R.V., de Brito, J., Dhir, R.K., 2016a. Establishing a relationship between modulus of elasticity and compressive strength of recycled aggregate concrete. *J. Cleaner Prod.* 112, 2171-2186.
- Silva, R.V., de Brito, J., Evangelista, L., Dhir, R.K., 2016b. Design of reinforced recycled aggregate concrete elements in conformity with Eurocode 2. *Constr. Build. Mater.* 105, 144-156.
- Silva, R.V., de Brito, J., Dhir, R.K., 2016c. Performance of cementitious renderings and masonry mortars containing recycled aggregates from construction and demolition wastes. *Constr. Build. Mater.* 105, 400-415.
- Silva, R.V., de Brito, J., Neves, R., Dhir, R., 2015a. Prediction of chloride ion penetration of recycled aggregate concrete. *Mater. Res.* 18(2), 427-440.
- Silva, R.V., Neves, R., de Brito, J., Dhir, R.K., 2015b. Carbonation behaviour of recycled aggregate concrete. *Cem. Concr. Compos.* 62, 22-32.
- Silva, R.V., de Brito, J., Dhir, R.K., 2015c. Comparative analysis of existing prediction models on the creep behaviour of recycled aggregate concrete. *Eng. Struct.* 100, 31-42.
- Söderholm, P., 2011. Taxing virgin natural resources: Lessons from aggregates taxation in Europe. *Resour. Conserv. Recy.* 55(11), 911-922.
- SymondsGroup, 1999. Construction and demolition waste management practices, and their economic impacts, Report to DGXI, European Commission, 215 p.
- Tam, V.W.Y., 2008. Economic comparison of concrete recycling: A case study approach. *Resour. Conserv. Recy.* 52(5), 821-828.
- Tam, V.W.Y., Butera, A., Le, K.N., 2016. Carbon-conditioned recycled aggregate in concrete production. *J. Cleaner Prod.* 133, 672-680.
- Tam, W.Y.V., Kotrayothar, D., Xiao, J.Z., 2016. Optimal mix approach for recycled aggregate concrete. *Concrete in Australia* 42(2), 37-45.

- Tam, V.W.Y., Lu, W., 2016. Construction waste management profiles, practices, and performance: A cross-jurisdictional analysis in four countries. *Sustainability* 8(2), 190-205.
- Teranishi, K., Dosho, Y., Narikawa, M., Kikuchi, M., 1998. Application of recycled aggregate concrete for structural concrete: Part 3 - Production of recycled aggregate by real-scale plant and quality of recycled aggregate concrete, in: Dhir, R.K., Henderson, N.A., Limbachiya, M.C. (Eds.), *Proceedings of the International Symposium on Sustainable construction: Use of recycled concrete aggregate*. Thomas Telford, London, UK, pp. 143-156.
- Tietenberg, T., 2002. *Environmental and natural resource economics*, 6th ed. Addison Wesley, New York, USA.
- Trevorrow, A., Lyne, T., 1998. Recycled aggregate markets: where to start?, in: Dhir, R.K., Henderson, N.A., Limbachiya, M.C. (Eds.), *Proceedings of the International Symposium on Sustainable construction: Use of recycled concrete aggregate*. Thomas Telford, London, UK, pp. 493-504.
- Van Der Wegen, G., Haverkort, R., 1998. Recycled construction and demolition waste as a fine aggregate for concrete, in: Dhir, R.K., Henderson, N.A., Limbachiya, M.C. (Eds.), *Proceedings of the International Symposium on Sustainable construction: Use of recycled concrete aggregate*. Thomas Telford, London, UK, pp. 333-346.
- Vyncke, J., Rousseau, E., 1993. Recycling of construction and demolition waste in Belgium: Actual situation and future evolution, in: Lauritzen, E.K. (Ed.), *Proceedings of the Third International RILEM Symposium on Demolition and Reuse of Concrete and Masonry*. CRC Press, Odense, Denmark, pp. 60-74.
- Weimann, K., Müller, A., 2004. Properties of building materials gained from wet-processed crushed concrete fines, in: Vázquez, E., Hendriks, C., Janssen, G.M.T. (Eds.), *International RILEM Conference on the Use of Recycled Materials in Building and Structures*. RILEM Publications SARL, Barcelona, Spain, pp. 133-141.
- WRAP, 2003a. Use of recycled concrete aggregate in construction of a footway. *Waste & Resources*

Action Programme, Oxon, UK, 3 p.

WRAP, 2003b. Use of recycled and secondary aggregates in the construction of the Newport Southern Distributor Road. Waste & Resources Action Programme, Oxon, UK, 4 p.

WRAP, 2004. The cost benefits of large scale usage of recycled and secondary aggregates on the A6 Alvaston Bypass. Waste & Resources Action Programme, Oxon, UK, 5 p.

Yanagi, K., Kasai, Y., Kaga, S., Abe, M., 1998. Experimental study on the applicability of recycled aggregate concrete to cast-in-place concrete pile, in: Dhir, R.K., Henderson, N.A., Limbachiya, M.C. (Eds.), Proceedings of the International Symposium on Sustainable construction: Use of recycled concrete aggregate. Thomas Telford, London, UK, pp. 359-370.

Zhan, B.J., Poon, C.S., Liu, Q., Kou, S.C., Shi, C.J., 2014. Experimental study on CO₂ curing for enhancement of recycled aggregate properties. *Constr. Build. Mater.* 67, 3-7.

Zhao, W., Rotter, S., 2008. The current situation of construction & demolition waste management in China, 2nd International Conference on Bioinformatics and Biomedical Engineering, ICBBE 2008. IEEE Computer Society, Shanghai, pp. 4747-4750.

Zhao, W., Leeftink, R.B., Rotter, V.S., 2010. Evaluation of the economic feasibility for the recycling of construction and demolition waste in China-The case of Chongqing. *Resour. Conserv. Recy.* 54(6), 377-389.

Table captions

Table 1 - Size of the reclamation industry (CRWP, 2007)

Table 2 - Positive environmental impacts of using RA (Bond, 2005)

Table 3 - Summary of methods used to reduce, reuse and recycle CDW (Guthrie, 1997)

Table 4 - Component elements of selective demolition (SymondsGroup, 1999)

Table 5 - Factors influencing the choice of the demolition method (Kasai, 1998)

Table 6 - Hand-operated demolition tools (Lamond et al., 2002)

Table 7 - Heavy demolition equipment (Hendriks and Pietersen, 2000; Lamond et al., 2002)

Table 8 - Thermal cutting equipment (Hendriks and Pietersen, 2000)

Table 9 - Mechanical cutting and grinding equipment (Lamond et al., 2002)

Table 10 - Expansion-based methods (Hendriks and Pietersen, 2000)

Table 11 - Advantages and disadvantages of using mobile or stationary recycling plants

Table 12 - Alternative contamination removal methods for old adhered mortar

Table 13 - Description of factors affecting the production and use of certified RA (Trevorrow and Lyne, 1998)

Figure captions

- Figure 1 - Main barriers that prevent a wider use of recycled aggregates in construction
- Figure 2 - Current and appropriate uses of aggregates (adapted from Dhir et al. (2004))
- Figure 3 - Composition of CDW (adapted from Schlauder and Brickner (1993))
- Figure 4 - Product performance based on the quality of aggregate used
- Figure 5 - Example of a mobile crusher (1 - feeding hopper; 2 - oscillating conveyor; 3 - jaw crusher; 4 - discharging transport belt; 5 - diesel engine as power unit; 6 - mobile by wheels, crawlers or skids) (adapted from Kumbhar et al. (2013))
- Figure 6 - Proper procedure for acceptance and processing of CDW at recycling plants (Hendriks, 1998)
- Figure 7 - Recycling procedure of CDW (adapted from Hansen (1992))
- Figure 8 - Examples of (a) a jaw crusher (b) an impact crusher and (c) a cone crusher (Crushersale, 2013; Penncrusher, 2013)
- Figure 9 - Fixed electromagnets (a) and rotating magnetic belts (b) (adapted from Nordberg (1994))



Figure 1 - Main barriers that prevent a wider use of recycled aggregates in construction

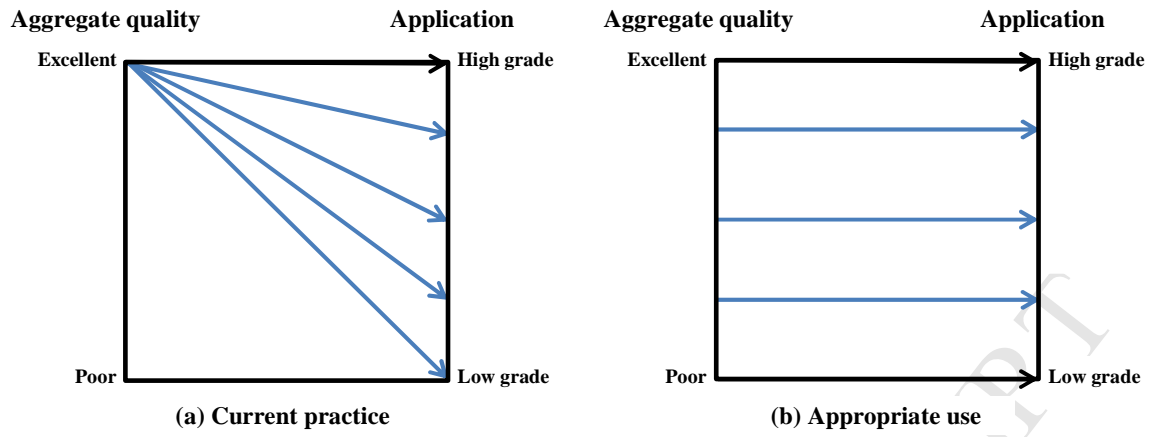

Figure 2 - Current and appropriate uses of aggregates (adapted from Dhir et al. (2004))

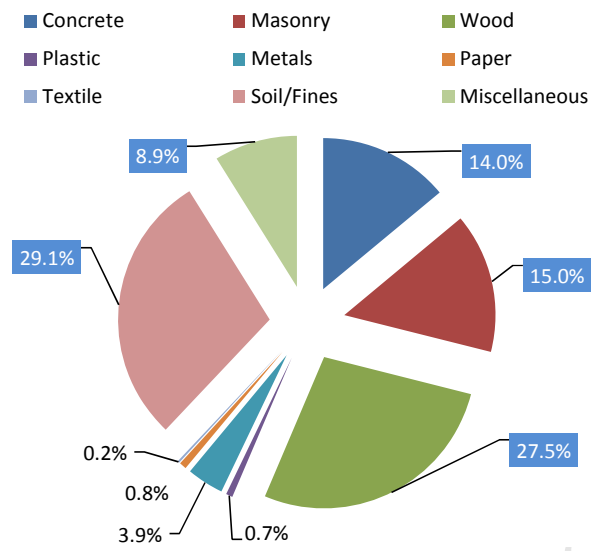

Figure 3 - Composition of CDW (adapted from Schlauder and Brickner (1993))

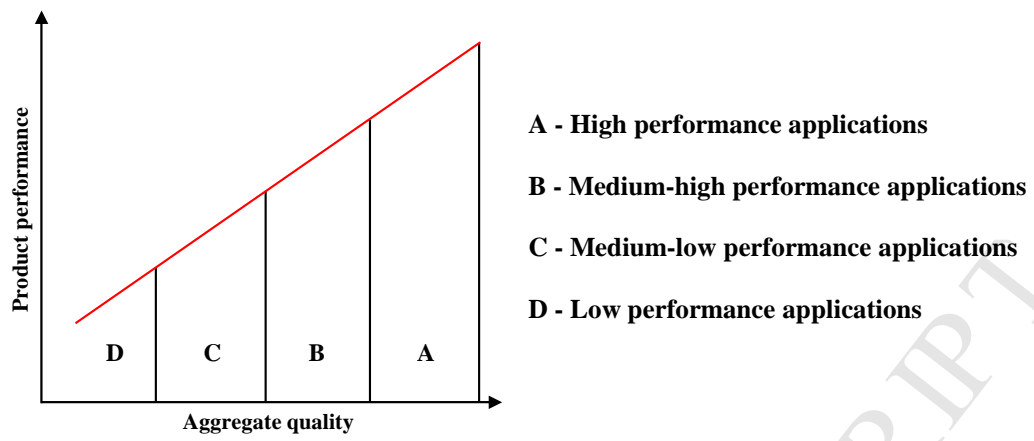

Figure 4 - Product performance based on the quality of aggregate used

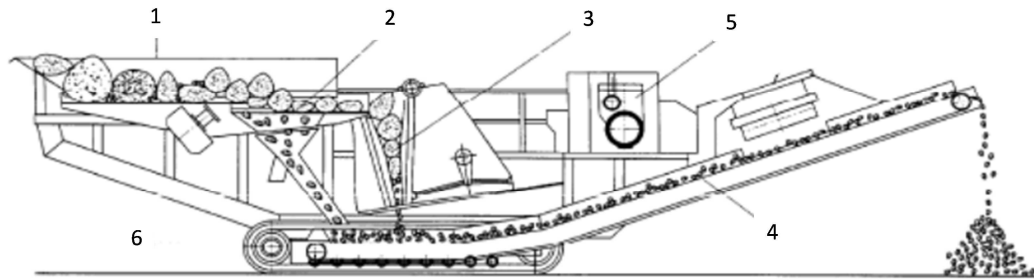

Figure 5 - Example of a mobile crusher (1 - feeding hopper; 2 - oscillating conveyor; 3 - jaw crusher; 4 - discharging transport belt; 5 - diesel engine as power unit; 6 - mobile by wheels, crawlers or skids) (adapted from Kumbhar et al. (2013))

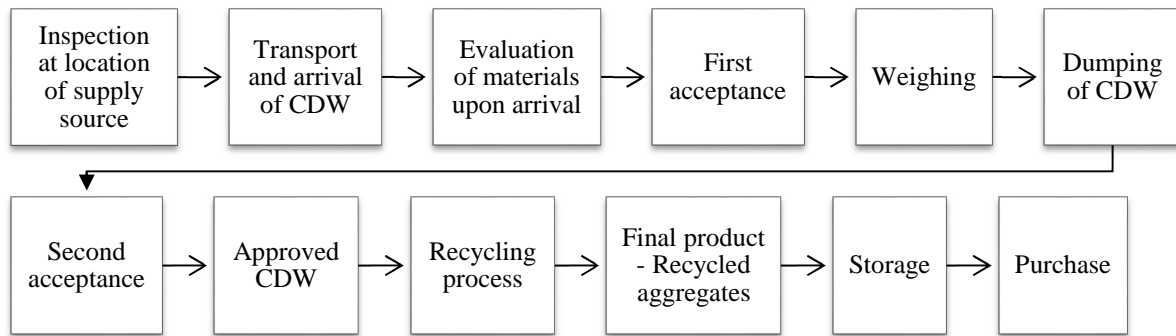

Figure 6 - Proper procedure for acceptance and processing of CDW at recycling plants (adapted from Hendriks, 1998)

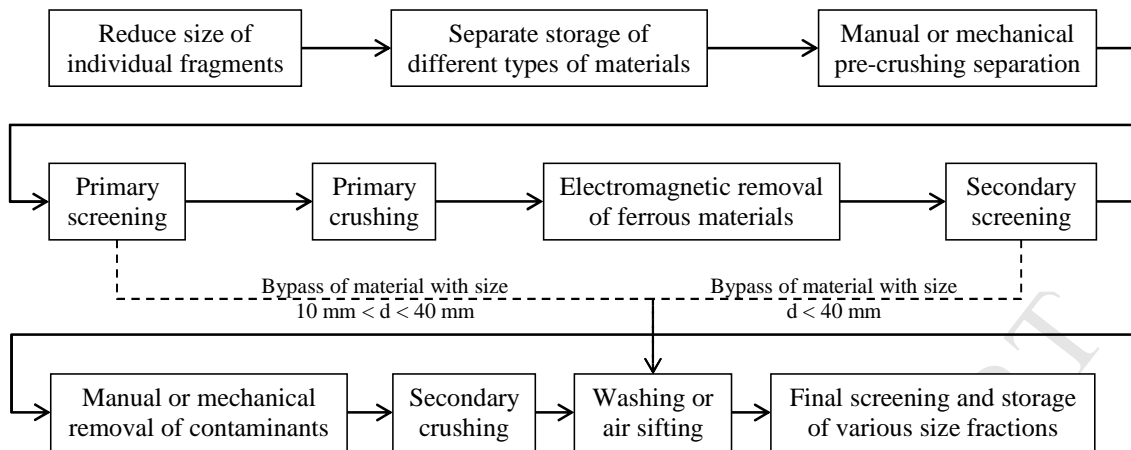

Figure 7 - Recycling procedure of CDW (adapted from Hansen (1992))

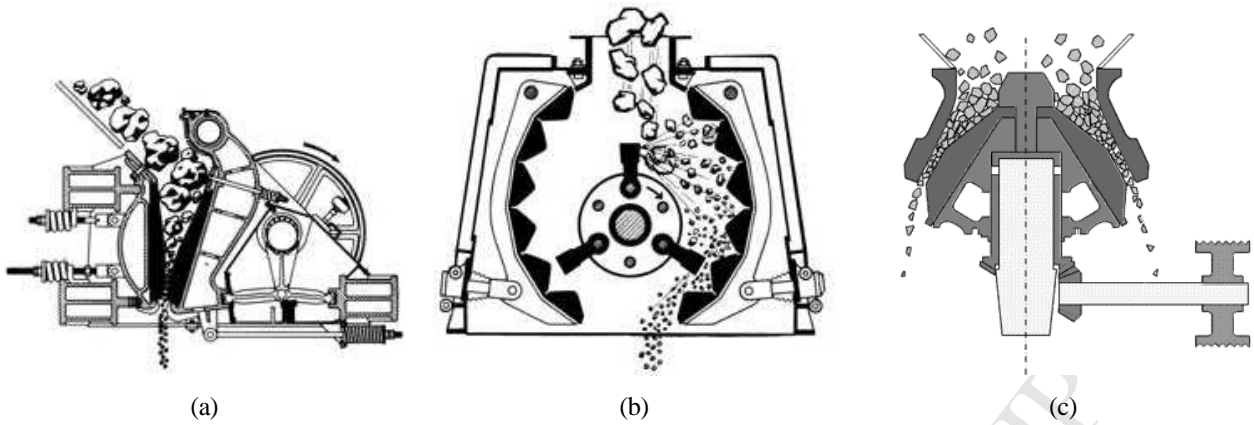

Figure 8 - Examples of (a) a jaw crusher (b) an impact crusher and (c) a cone crusher (Crushersale, 2013; Penncrusher, 2013)

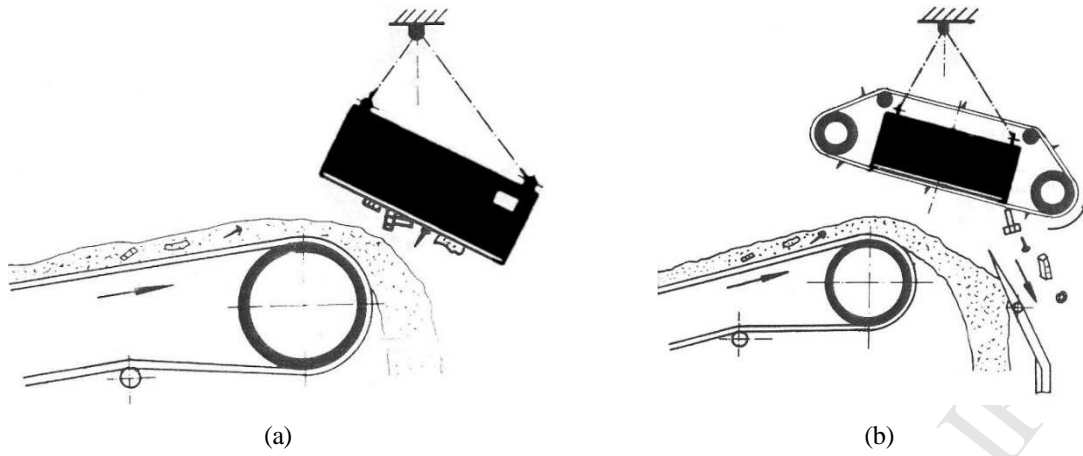

Figure 9 - Fixed electromagnets (a) and rotating magnetic belts (b) (adapted from Nordberg (1994))