

# Identification and optimal selection of temperature-sensitive measuring points of thermal error compensation on a heavy-duty machine tool

Liu, Quan; Yan, Junwei; Pham, Duc; Zhou, Zude; Xu, Wenjun; Wei, Qing; Ji, Chunqian

DOI:

[10.1007/s00170-015-7889-1](https://doi.org/10.1007/s00170-015-7889-1)

License:

None: All rights reserved

*Document Version*

Peer reviewed version

*Citation for published version (Harvard):*

Liu, Q, Yan, J, Pham, D, Zhou, Z, Xu, W, Wei, Q & Ji, C 2016, 'Identification and optimal selection of temperature-sensitive measuring points of thermal error compensation on a heavy-duty machine tool', *The International Journal of Advanced Manufacturing Technology*, vol. 85, pp. 345–353.  
<https://doi.org/10.1007/s00170-015-7889-1>

[Link to publication on Research at Birmingham portal](#)

## **Publisher Rights Statement:**

The final publication is available at Springer via <http://dx.doi.org/10.1007/s00170-015-7889-1>

Checked 25/8/2016

## **General rights**

Unless a licence is specified above, all rights (including copyright and moral rights) in this document are retained by the authors and/or the copyright holders. The express permission of the copyright holder must be obtained for any use of this material other than for purposes permitted by law.

- Users may freely distribute the URL that is used to identify this publication.
- Users may download and/or print one copy of the publication from the University of Birmingham research portal for the purpose of private study or non-commercial research.
- User may use extracts from the document in line with the concept of 'fair dealing' under the Copyright, Designs and Patents Act 1988 (?)
- Users may not further distribute the material nor use it for the purposes of commercial gain.

Where a licence is displayed above, please note the terms and conditions of the licence govern your use of this document.

When citing, please reference the published version.

## **Take down policy**

While the University of Birmingham exercises care and attention in making items available there are rare occasions when an item has been uploaded in error or has been deemed to be commercially or otherwise sensitive.

If you believe that this is the case for this document, please contact [UBIRA@lists.bham.ac.uk](mailto:UBIRA@lists.bham.ac.uk) providing details and we will remove access to the work immediately and investigate.

# Identification and optimal selection of temperature-sensitive measuring points of thermal error compensation on a heavy-duty machine tool

Quan Liu<sup>1,2</sup>, Junwei Yan<sup>1,2</sup>, Duc Truong Pham<sup>3</sup>, Zude Zhou<sup>1,2</sup>, Wenjun Xu<sup>1,2</sup>, Qing Wei<sup>1,2</sup>, Chunqian Ji<sup>3</sup>

<sup>1</sup>School of Information Engineering, Wuhan University of Technology, Wuhan 430070, China

<sup>2</sup>Key Lab. of Fiber Optic Sensing Technology and Information Processing

Ministry of Education

Wuhan University of Technology

Wuhan, China

<sup>3</sup>School of Mechanical Engineering, University of Birmingham, Birmingham B15 2TT, UK

## Abstract

Thermal error compensation is considered as an effective and economic method to improve the machining accuracy for a machine tool. The performance of thermal error prediction mainly depends on the accuracy and robustness of predictive model and the input temperature variables. Selection of temperature-sensitive measuring points is the premise of thermal error compensation. In the thermal error compensation scheme for heavy-duty computer numerical control (CNC) machine tools, the identification of temperature-sensitive points still lacks an effective method due to its complex structure and heat generation mechanisms. In this paper, an optimal selection method of temperature-sensitive measuring points has been proposed. The optimal measuring points are acquired through three steps. Firstly, the degree of temperature sensitivity is defined and used to select the measuring points with high sensitivity to thermal error. Then the first selected points are classified with fuzzy clustering and grey correlation grade. Finally, the temperature-sensitive measuring points are selected with analysis of location of temperature sensors. In order to verify the method above, an experiment is carried out on the CR5116 of flexible machining center. A novel temperature sensor, Fibre Bragg Grating (FBG) sensor, is used to collect the surface temperature of the machine. A thermal error compensation model is developed to analyze the prediction accuracy based on four sequences of measuring points, which are generated by different selection approaches. The results show the number of the measuring points is reduced from 27 to 5 through the proposed selection method and the thermal error compensation model based on the optimum temperature-sensitive measuring points has the best performance of prediction effect robustness.

**Keywords** Temperature-sensitive measuring points, FBG sensors, Heavy-duty machine tools, Thermal errors

## 1. Introduction

Thermally induced errors and geometric errors are the two main contributors to the inaccuracies on machined workpieces [1]. However, according to the statistics, the thermal errors, caused by internal and external heat sources accounts for as much as 70% of the total workpiece errors in machining [2].

Compared with the geometric error [3], the thermal errors caused by the thermal deformation of the machine structure are time dependent and dynamic. There are many strategies to reduce the thermal errors, such as designing a thermo-symmetric machine with cooling systems, using low expansion materials, controlling the humidity and temperature of the workshop and adopting thermal errors compensation [4]. Due to the complex heat generation mechanisms and various internal and external heat sources, the thermal errors can't be eliminated completely in the design stage and the software compensation method is considered as the most economic and effective way to reduce the thermal error [5].

In general, the research on thermal error compensation includes two parts: the thermal errors compensation modeling [1, 2, 6] and the real-time compensation devices [7]. The compensation models are used to predict the thermal error through accurately mapping the empirical relationship between temperature values and thermal errors of the machine tools. However, the temperature measurement and the selection of temperature-sensitive measuring points are the premise of the thermal error compensation models.

In recent years, many researches have been done on the selection methods of thermal key measuring points. These methods can be categorized into two types according to their characteristics: mechanism analysis and statistics analysis. Mechanism analysis methods concentrate on the generation mechanism of thermal error on machine tools, such temperature field calculation and displacement field analysis. Finite element method (FEM) [8] and finite difference method (FDM) [9] are two main mechanism analysis methods, which are used to analyze the temperature distribution and the deformation at particular points. In the field of statistics analysis, various models and algorithms, such as correlation theory [10, 11], grey correlation theory [12, 13], neural network [14–16], fuzzy clustering [17–20], partial correlation analysis [21] and stepwise multiple regression analysis [22] etc, have been proposed to identify the key temperature measuring points. Liang [23] presented a method using correlation coefficient and multiple linear regressions to identify the key measuring points of a horizontal machine center. Li [12] used the grey system theory to select the optimal measuring points and verify the performance of this method. Miao [24] combined the fuzzy clustering and grey correlation theory to identify the temperature-sensitive points, and then established the compensation models based on the temperature sequences of these points. Yang [25] proposed a grouping method of temperature variables. They were divided into groups based on the correlation coefficient, and then the key points were determined by permutation and combination of temperature variables of each group. Miao [26] used a comprehensive analysis method to identify the temperature-sensitive points, which was a combination of grey correlation, stepwise regression and fuzzy clustering.

The methods discussed above both have advantages and disadvantages in temperature-sensitive points selection. Due to the complex process of heat transfer and difficulties in determining the boundary condition, the performance of mechanism analysis methods is not good. In statistics analysis areas, correlation coefficient and grey system theory only consider the correlation between the temperature variables and thermal errors, which ignore the coupling problems among temperature variables. Fuzzy clustering theory is used to classify the temperature variables. However, the random selection of threshold makes various results in classification. In order to reduce the coupling and grouping problem, this paper proposes a new method combining the mechanism analysis and statistics analysis to select the optimal temperature measuring points.

Section 2 introduces temperature measurement method and chooses initial measurement points. Section 3 proposes a method for selecting temperature-sensitive measuring points. Section 4 describes the experimental set-up and evaluates the performance of thermal error compensation based on the selected

points.

## 2. Measurement of surface temperature and thermal error on heavy-duty CNC machine tool

This study was carried out on a CR5116 flexible machining center (FMC). Due to the complex heat generation mechanisms of the machine tools, it's difficult to determine the measuring positions of the machine tools and the numbers of the temperature sensors. The FMC heat sources, causing the thermal errors, are always come from two main aspects, internal and external sources. The internal sources main include the heat generated by spindle motor, spindle bearing, ball screw system and cool system etc. The external ones are from sunlight, heater and personal radiations. All these heat sources will effect the temperature field distribution and cause the heat deformation and relative displacement of components on the machine tool. In order to monitor the thermal behavior of the FMC, twenty-seven measuring points were selected according to the main heat sources, such as headstock, drive motor, ball screw and environmental temperature. In this paper, FBG sensors [27, 28] were used to collect the surface temperature data of FMC. Compared with PT100 platinum resistance sensors, FBG sensors have the advantages in temperature measurement on the heavy-duty machine tools, such as easy deployment, anti-electromagnetic and small size. In this experiment, FBG sensors were attached on the surface of the FMC. Fig.1 shows the details of the temperature measuring points and locations of FBG sensors. The FBG sensors can be divided into 5 groups according to their locations, as shown in table 1.

The other parameters to be collected are the thermal errors of the spindle in the X, Y, Z directions. Three CCD Laser Displacement Sensors were used to measure the thermal drifts of the spindle in the three directions.

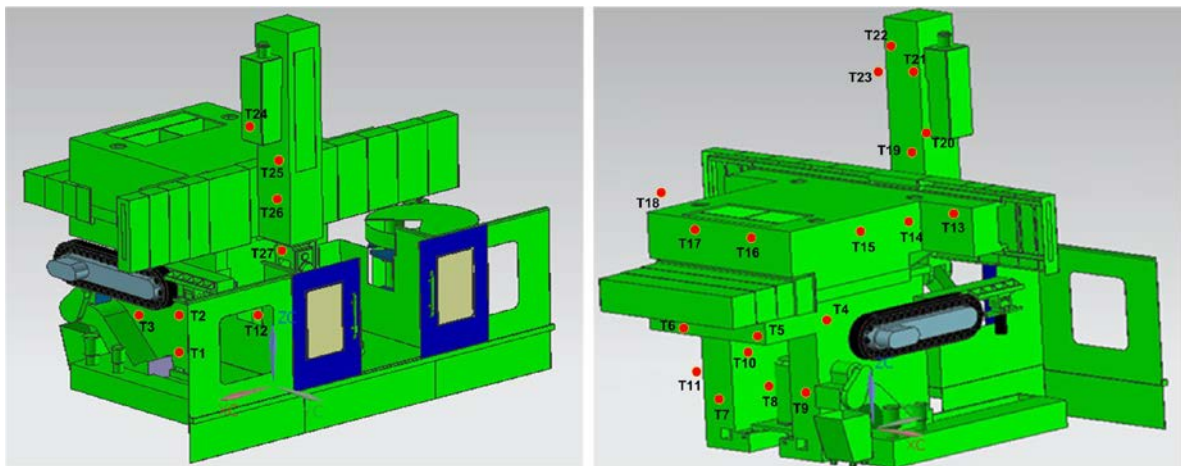

Fig.1 The deployment of FBG sensors

Table1. Classification of FBG sensors

Position	FBG Sensors No.	Total
Bed	T1,T2,T3,T4,T5,T6,T7,T8,T9,T10	10
Column	T13,T14,T15,T16,T17	5
Headstock	T19,T20,T21,T22,T23	5

Tool rest	T25,T26,T27	3
Environment	T11,T12,T18,T24	4

### 3. Temperature-sensitive measuring points selection

In this section, we introduce the method for temperature-sensitive measuring point selection, which is based on correlation analysis, correlation analysis, temperature sensitivity analysis and fuzzy clustering.

As shown in Fig.2, the processes of optimal selection for temperature measuring points can be divided into three parts. In the first selection, the temperature variables will be sorted according to the degree of thermal error sensitivity and generated a new sequence. The measuring points in the first half of the sequence are chosen for further analysis. In the second selection, the grey relation grades between the first selected measuring points and thermal errors are calculated and then these measuring points will be classified into different groups using fuzzy clustering. The second selected sequence of measuring points will be got by choosing the point with maximum grey relation grade in each group. In the third selection, the second selected sequence will be analyzed by combining with the location of sensors. Through the three steps, the temperature-sensitive measuring points are identified. The definitions and algorithms used in the three selections are described as below.

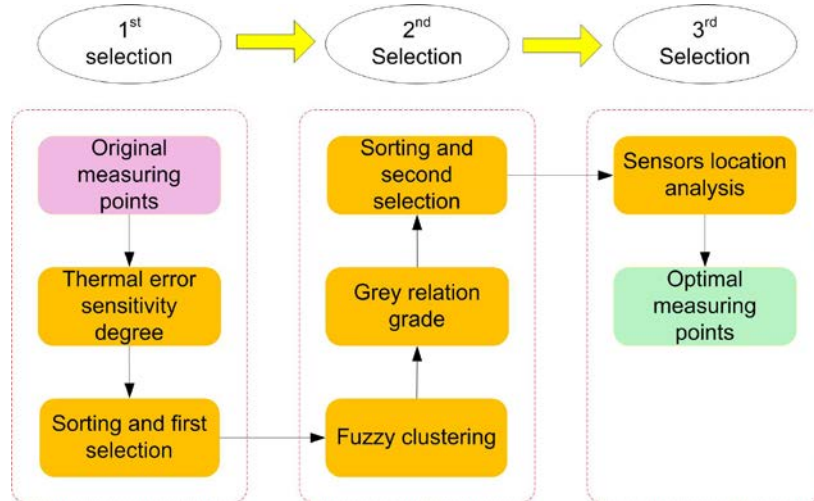

Fig2. The processes of temperature-sensitive measuring points selection

#### 3.1 Definition of thermal error sensitivity

In order to facilitate the analysis and description, the thermal error and temperature data sets can be represented as  $y = \{y(k) | k = 1, 2, \dots, m\}$  and  $x_i = \{x_i(k) | k = 1, 2, \dots, m; i = 1, 2, \dots, n\}$  separately, in which  $n$  means the number of temperature measuring points and  $k$  is the sample size.

The thermal error sensitivity represents the impact degree of temperature changes on thermal errors. The coefficient of thermal error sensitivity defined as

$$S_i(k) = \frac{dY(k)}{dX_i(k)} = \lim_{\Delta X \rightarrow 0} \frac{\Delta Y(k)}{\Delta X_i(k)} \quad (1)$$

As  $\Delta X_i$  might be zero in different measuring points, it's much easier to calculate the reciprocal of  $S_i$ ,

which is  $\frac{1}{S_i(k)} \approx \frac{\Delta X_i(k)}{\Delta Y(k)}$ . The degree of thermal error sensitivity  $G_i$  will be calculated as equation (2),

in which  $\overline{\left(\frac{\Delta X_i(k)}{\Delta Y(k)}\right)}$  presents the average value of  $\frac{\Delta X_i(k)}{\Delta Y(k)}$ .

$$G_i = \frac{1}{D_i} = \frac{1}{\sqrt{\sum_{k=1}^m \left( \frac{\Delta X_i(k)}{\Delta Y(k)} - \overline{\left(\frac{\Delta X_i(k)}{\Delta Y(k)}\right)} \right)^2}} \quad (2)$$

The value of  $G_i$  is bigger, the more sensitive the temperature measuring point is.

### 3.2 Grey correlation analysis

Grey system theory presented by Deng [29], aims to evaluate the relationship of a series of data through analyzing the geometric similarity of the data curves. The grey correlation grade indicates the close degree between two series, which is calculated by grey correlation coefficient. In this study, we assume the original sequence and the sequence for comparison as  $y = \{y(k) | k = 1, 2, \dots, m\}$  and  $x_i = \{x_i(k) | k = 1, 2, \dots, m; i = 1, 2, \dots, n\}$  separately. In grey system theory, the grey correlation coefficient is defined as

$$\xi_{0i}(k) = \frac{\Delta_{\min} + \rho \Delta_{\max}}{\Delta_{0i}(k) + \rho \Delta_{\max}} \quad (3)$$

$\rho$  is the distinguishing coefficient and it is taken as 0.5 in general.  $\Delta_{0i}(k)$  is defined as  $\Delta_{0i}(k) = |x_0(k) - x_i(k)|$ .  $\Delta_{\min}$  and  $\Delta_{\max}$  mean the minimum and maximum of  $\Delta_{0i}(k)$ , which are defined as  $\Delta_{\min} = \min_i \min_k \Delta_{0i}(k)$  and  $\Delta_{\max} = \max_i \max_k \Delta_{0i}(k)$ . The grey correlation grad is defined as:

$$\gamma_{0i} = \frac{1}{m} \sum_{k=1}^m \xi_{0i}(k) \quad (4)$$

### 3.3 Fuzzy clustering analysis

Fuzzy clustering is used to establish the fuzzy relationship among temperature variables. The temperature variables will be classified based on a specific threshold. As shown in Fig.3, there are 5 main steps in fuzzy clustering analysis, which are normalization, correlation coefficient calculation, establishment of fuzzy similarity matrix, threshold determining and variables classification.

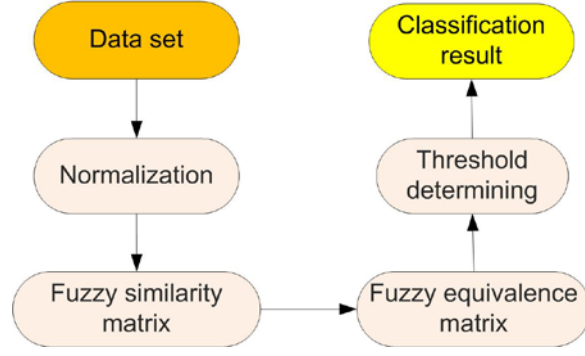

Fig3.fuzzy clustering processes

1. Data normalization aims to increase the cohesion of entity types and reduce the data redundancy. We use variable  $C$  as a normalized value of  $X$ , which is calculated as:

$$c_i(k) = \frac{x_i(k)}{\max |x_i(k)|} \quad (5)$$

2. Fuzzy similarity matrix is defined as  $R = (r_{ij})_{n \times n}$ , constructed by the relation coefficient  $r_{ij}$ . The  $r_{ij}$  describes the linear relationship between  $c_i$  and  $c_j$  and is calculated as:

$$r_{ij} = \frac{\sum_{k=1}^m (c_i(k) - \bar{c}_i(k))(c_j(k) - \bar{c}_j(k))}{\sqrt{\sum_{k=1}^m (c_i(k) - \bar{c}_i(k))^2 \sum_{k=1}^m (c_j(k) - \bar{c}_j(k))^2}} \quad (6)$$

$\bar{c}_i(k)$  and  $\bar{c}_j(k)$  mean the average value of sequence  $c_i(k)$  and  $c_j(k)$ .

3. As the fuzzy similarity matrix  $R = (r_{ij})_{n \times n}$  is not transitive, a fuzzy equivalence matrix should be created for variables classification. We assume  $t(R)$  as the fuzzy equivalence of  $R$ . If there exists an integer  $l$ , which satisfies  $R^{2l} = R^{2l+1}$ , then the fuzzy equivalence matrix can be defined  $t(R) = R^{2l}$ .

4. Threshold determining is the last step before classification. The value of the threshold  $\lambda$  directly determines the result of variables classification. So the temperature variables will be classified into different groups with different thresholds. In this research,  $\lambda$  is determined by the number of temperature variables. For example, if the amount of temperature variables is  $n$ , the threshold  $\lambda$  will be chosen, when the number of classified groups is around  $n/2$ .

## 4. Example verification

### 4.1 Experiment setup

An experiment was designed to identify the temperature-sensitive measuring points on a flexible manufacturing center CR5116. Based on the temperature data collected from the measuring points, thermal errors compensation model was developed to analyze the feasibility and performance of the method for key measuring points selection.

Fig.4 shows the temperature and thermal errors collection based on FBG sensors and CCD laser displacement sensors. There were 27 FBG sensors deployed on the surface of FMC, as shown in Fig.1. Three CCD sensors were used to measure the thermal errors of X, Y and Z direction of spindle.

The experiment lasted for three days with air cutting, which means the FMC run without implementing real cutting process and the measuring system collected data per minute, including temperature values and the spindle thermal errors. The collected data were divided into three groups according to the date: data01, data02, data03. The first group was used to select the temperature-sensitive measuring points. The second and the third ones were used to verify the effectiveness and robustness of the thermal error compensation model based on the selected points. Fig. 5 shows the thermal errors of X, Y, Z directions of spindle. It's obvious that the biggest change of the thermal error happened in Y directions. So the thermal error in Y direction was only considered in the experiment.

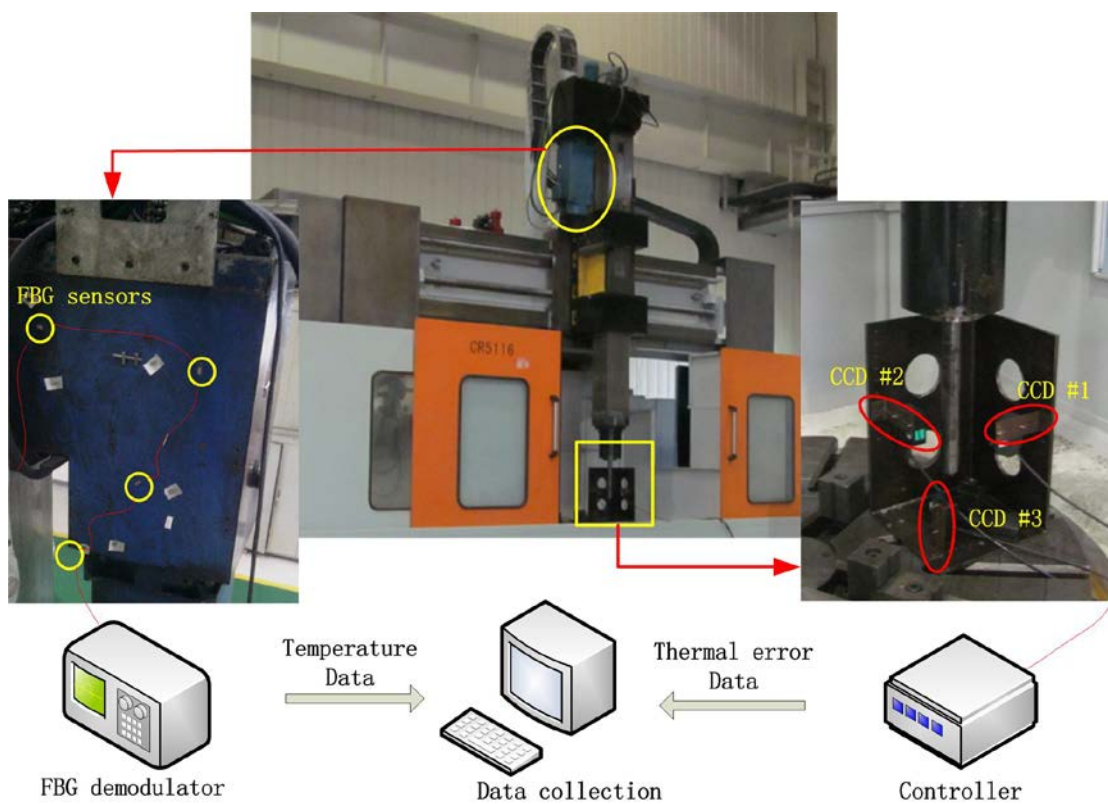

Fig.4 Temperature and thermal errors collection system



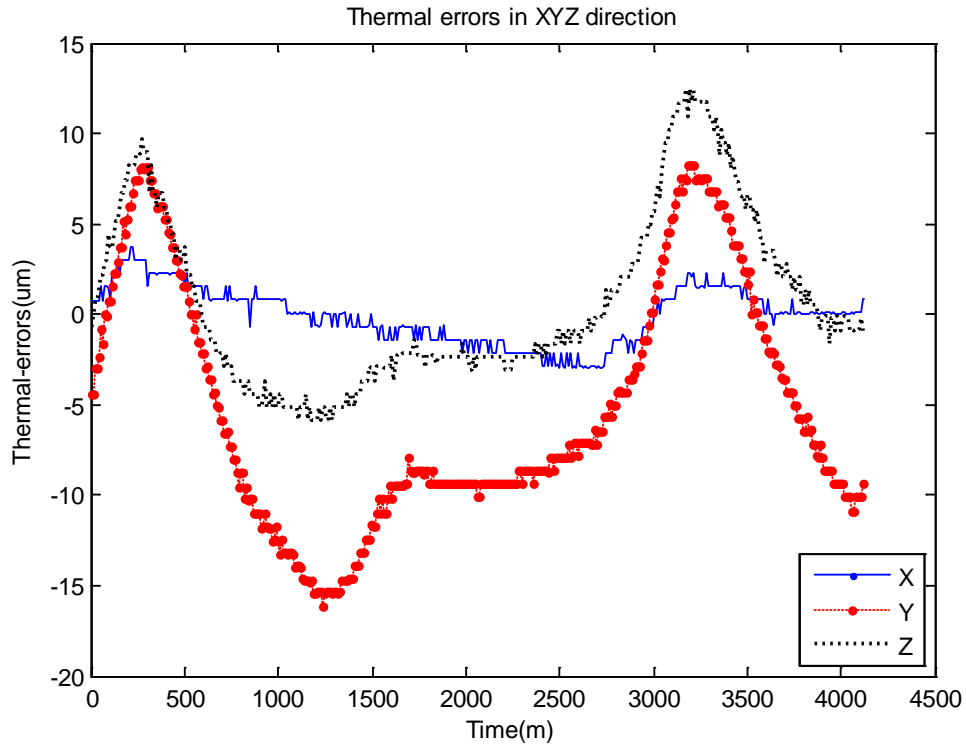

Fig. 5 Comparison of thermal errors in XYZ directions

#### 4.2 Temperature-sensitive measuring points selection

As discussed in section 3, an integrated method can be used to select the temperature-sensitive points. In this paper, data01 was considered as the original data set for identification of the measuring points. Based on the processes in Fig. 2, the simulation results of each step were obtained using Matlab, which were listed as below:

1. According to the Eq. (2), the degrees of thermal error sensitivity for the 27 measuring points were calculated. Table 2 shows the results of each measuring point.

Table 2. The degree of thermal error sensitivity

T1	T2	T3	T4	T5	T6	T7	T8	T9	T10
0.0123	0.0125	0.0105	0.0049	0.0114	0.0133	0.0170	0.0130	0.0142	0.0073
T11	T12	T13	T14	T15	T16	T17	T18	T19	T20
0.0115	0.0124	0.0069	0.0130	0.0128	0.0086	0.0136	0.0089	0.0105	0.0072
T21	T22	T23	T24	T25	T26	T27			
0.0116	0.0132	0.0103	0.0157	0.0082	0.0108	0.0110			

The first selection of temperature-sensitive measuring points was made based on the degrees of thermal error sensitivity. Firstly, the temperature measuring points were sorted by the values shown in table 2. Then, the top 14 points were selected for further analysis. So T1, T2, T6, T7, T8, T9, T11, T12, T14, T15, T18, T22, T23 and T25, were selected and others were abandoned.

2. The 14 primary points were classified into different groups with fuzzy clustering algorithms. The first step was the calculation of fuzzy equivalence matrix  $t(R)$ . According to the Eq. (6),  $t(R)$  was calculated and shown as Fig. 6. The second one was threshold ( $\lambda$ ) selection, which was determined by the number of primary points and the classification of measuring points. The goal of this step was to reduce by around

half the amount of primary variables. As the number of primary points was 14, the temperature variables could be divided into 6, 7 and 8 groups with different thresholds. The third step was calculation of grey correlation grades between temperature variables and thermal errors. The results were sorted and shown as table 3. The final step was selecting temperature variables in each classification. The point with max value of grey correlation grade was selected in each group. Three temperature variables sequences were got, which were  $r_1=[T_2 T_6 T_{12} T_{14} T_{23} T_{25}]$ ,  $r_2=[T_2 T_6 T_7 T_{12} T_{14} T_{23} T_{25}]$ , and  $r_3=[T_2 T_6 T_7 T_{12} T_{14} T_{23} T_{25}]$ , as shown in Table 4.

Table3. The grey correlation grades between temperature variables and thermal errors

T12	T8	T10	T11	T18	T9	T23	T15	T17
0.8372	0.8314	0.8273	0.8144	0.8143	0.8098	0.8041	0.7976	0.7926
T24	T7	T14	T13	T19	T1	T21	T22	T3
0.7676	0.7674	0.7514	0.7421	0.7394	0.7394	0.7194	0.7152	0.7129
T16	T25	T20	T26	T27	T6	T2	T4	T5
0.7111	0.7073	0.6978	0.6959	0.6849	0.6825	0.6771	0.6556	0.6552

Table 4 Classifications of measuring points with different thresholds

Threshold	Classification								Second Selection of temperature variables
	i.	ii.	iii.	iv.	v.	vi.	vii.	viii.	
$\lambda = 0.8996$	T1 T7 T8 T9 T11 T12 T15 T18, T22	T2	T6	T14	T23	T25			T2 T6 T12 T14 T23 T25
$\lambda = 0.9017$	T1 T8 T9 T11 T12 T15 T18 T22	T2	T6	T7	T14	T23	T25		T2 T6 T7 T12 T14 T23 T25
$\lambda = 0.9095$	T1 T8 T9 T11 T12 T15 T18	T2	T6	T7	T14	T22	T23	T25	T2 T6 T7 T12 T14 T22 T23 T25

$$t(R) = \begin{pmatrix} 1.0000 \\ 0.7281 & 1.0000 \\ 0.8996 & 0.7281 & 1.0000 \\ 0.8996 & 0.7281 & 0.9715 & 1.0000 \\ 0.8304 & 0.7281 & 0.8304 & 0.8304 & 1.0000 \\ 0.8145 & 0.7281 & 0.8145 & 0.8145 & 0.8145 & 1.0000 \\ 0.8996 & 0.7281 & 0.9458 & 0.9458 & 0.8304 & 0.8145 & 1.0000 \\ 0.8337 & 0.7281 & 0.8337 & 0.8337 & 0.8304 & 0.8145 & 0.8337 & 1.0000 \\ 0.8996 & 0.7281 & 0.9147 & 0.9147 & 0.8304 & 0.8145 & 0.9147 & 0.8337 & 1.0000 \\ 0.5766 & 0.5766 & 0.5766 & 0.5766 & 0.5766 & 0.5766 & 0.5766 & 0.5766 & 0.5766 & 1.0000 \\ 0.8996 & 0.7281 & 0.9270 & 0.9270 & 0.8304 & 0.8145 & 0.9270 & 0.8337 & 0.9147 & 0.5766 & 1.0000 \\ 0.8996 & 0.7281 & 0.9096 & 0.9096 & 0.8304 & 0.8145 & 0.9096 & 0.8337 & 0.9096 & 0.5766 & 0.9096 & 1.0000 \\ 0.8996 & 0.7281 & 0.9018 & 0.9018 & 0.8304 & 0.8145 & 0.9018 & 0.8337 & 0.9018 & 0.5766 & 0.9018 & 0.9018 & 1.0000 \\ 0.8996 & 0.7281 & 0.9715 & 0.9752 & 0.8304 & 0.8145 & 0.9458 & 0.8337 & 0.9147 & 0.5766 & 0.9270 & 0.9096 & 0.9018 & 1.0000 \end{pmatrix}$$

Fig. 6 The fuzzy equivalence matrix

3. The third selection was based on the positions of FBG sensors. As shown in table1, the temperature measuring points was divided into 5 groups. Only one measuring point was choosed in each group. In

order to eliminate coupling among temperature variables, the one with maximum value of grey correlation grade was selected. Based on  $r_1, r_2, r_3$ , the new sequences of measuring points were got, which were  $e_1=[T_6 T_{12} T_{14} T_{23} T_{25}]$  and  $e_2=e_3=[T_7 T_{12} T_{14} T_{23} T_{25}]$ . According to table3, the grey correlation grade of T7 was larger than T6, so we choosed e2 or e3 as the optimal measuring points.

#### 4.3 Models of thermal error compensation

In order to evaluate the performance of the method for measuring points selection, a thermal error prediction model was designed based on the Multi linear regression (MLR). In the experiment, MLR, as a statistical technique, was used to predict thermal error through several temperature variables. Data01 was used to establish the thermal error prediction model. T7, T12, T14, T23 and T25 were selected to establish regress equation. We assumed  $x_7, x_{12}, x_{14}, x_{23}$  and  $x_{25}$  as the temperature variables of the selected points. The prediction model was calculated as below:

$$y=6.5263x_7+5.1961x_{12}+0.1227x_{14}+4.5709x_{23}-4.9635x_{25}+14.1779 \quad (9)$$

Data02 and Data03 were used to analyze the prediction accuracy. The fitting accuracy for data0201 was shown as Fig.7 and the predictive effects of the two batches were shown as Fig. 8.

In order to compare the performance of the compensation model with different temperature variables, four measuring points sequences (G1, G2, G3 and G4) were chosen based on different selection methods. As shown in table1, the measuring points were divided into 5 groups according to their location. G2 consisted of the measuring points with maximum degree of temperature sensitivity in each group. G3 selected the measuring points with maximum grey correlation grade with thermal errors in each group. G4 concluded the measuring points, selected randomly in each group. The details of the sequences were shown in table 5 and the predictive performance based on each sequences of measuring points was shown in table 6.

Table 5. Measuring points sequences based on different selection models

Group No.	Selected measuring points	Selection method
G1	T7 T12 T14 T23 T25	Shown in section 4
G2	T7 T14 T18 T23 T25	Selecting measuring points with maximum thermal sensitive grad in each location area
G3	T8 T12 T15 T19 T23	Selecting measuring points with maximum Grey correlation grade in each location area
G4	T6 T15 T18 T22 T26	Selecting measuring points randomly in each location area

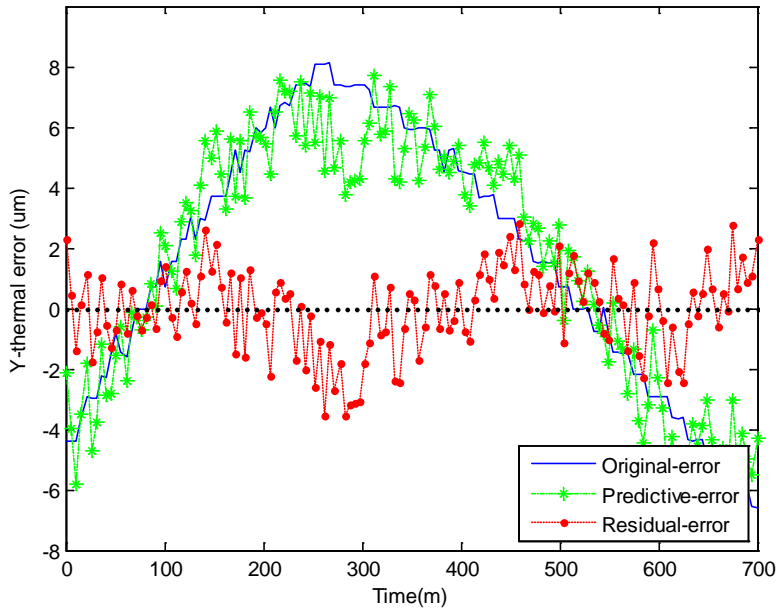
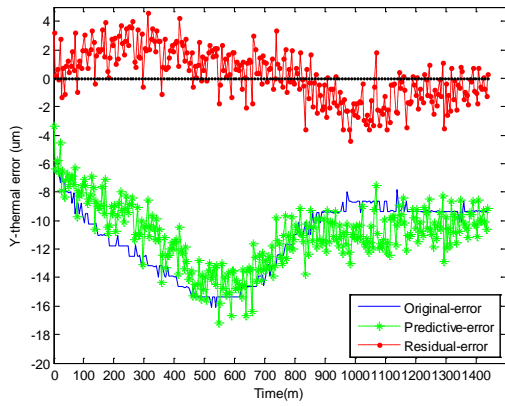
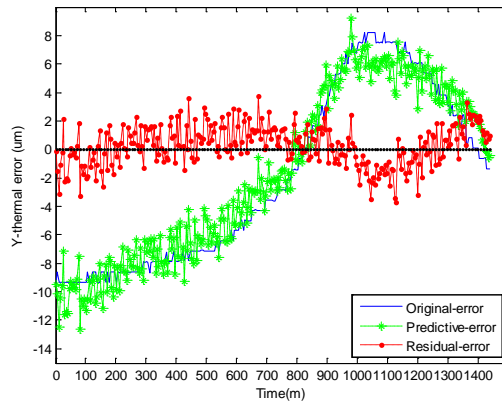

Fig.7 The fitting accuracy of Data0201



(a) The predictive effect of Data0202



(b) The predictive effect of Data0203

Fig.8 Analysis of predictive effects

From the table6, we can see that the mean error of G1, G2 and G3 was much smaller than that of G4. The max error of G4 is bigger than the original max error, which means G4 can't be used to predictive the thermal error. Through comparison of the four groups in terms of mean error, standard error and max error, G1 had the best performance of thermal error prediction and the predictive thermal error was reduced by 79.42%.

Table 6 Predictive effect comparison among four measuring points sequences

		Data0202		
Group No.		Mean error	Std. error	Max error
	Original value	11.1940	2.4323	16.1076
G1	Residual error	1.6003	1.9288	5.2796
G2	Residual error	1.4309	1.7552	5.0765

G3	Residual error	2.0735	2.0018	6.3235
G4	Residual error	4.4308	2.4857	11.4625

		Data0203		
Group No.		Mean error	Std. error	Max error
	Original value	5.8659	6.1626	10.0394
G1	Residual error	1.2073	1.9288	4.2989
G2	Residual error	1.9640	1.5568	5.3708
G3	Residual error	1.3859	1.3793	4.7506
G4	Residual error	8.8911	3.5468	15.0949

## 5. Conclusion

In this paper, FBG sensors have been used to collect the surface temperature of a heavy-duty machine tool. A new method of temperature-sensitive measuring points selection consists of three steps. The first step defines the degree of temperature sensitivity and the primary measuring points are got according to the degree of temperature sensitivity. The second step combines gray theory with fuzzy clustering. In this step, the first selected measuring points are classified with fuzzy clustering. The second-selected measuring points are chosen with comparison of grey grade for each temperature variable. Finally, the last step aims to select the optimal temperature measuring points by considering the locations of FBG sensors.

An experiment was carried out on a flexible machining center CR5116 to verify the method. By using the three selections, the temperature-sensitive points were identified. The number of measuring points was reduced from 27 to 5. Based on these measuring points, a thermal error prediction model was built to analyze the performance of the method for temperature-sensitive points selection. The experiment result based on data0202 shows that the average predictive residual error was reduced to 1.6 $\mu$ m and the maximum predictive residual thermal error was less than 5.3 $\mu$ m. In order to further demonstrate the effectiveness of the point selection method, three other methods were used to create three different measuring points sequences. Then a comparison was made among four thermal prediction models using data02 and data03, which were based on four measuring points sequences. The result shown that the prediction model with the temperature-sensitive points, selected by the method proposed in this paper, had the best performance of predictive accuracy.

## Acknowledgement

This research is supported by the National Natural Science Foundation of China (Grant No. 51475343), the International Science & Technology Cooperation Program of China (Grant No. 2015DFA70340), and Wuh an International Science and Technology Cooperation Project (Grant No. 2014030709020306).

## References

1. Li ZH, Yang JG, Fan KG, Zhang Y (2015) Integrated geometric and thermal error modeling and compensation for vertical machining centers. *Int J Adv Manuf Technol* 76:1139–1150
2. Mayr J, Jedrzejewski J, Uhlmann E, Donmez M A, Knapp W, Härtig F, Wendt K, Moriwaki T, Shore P, Schmitt R, Brecher C, Würz T, Wegener K (2012) Thermal issues in machine tools. *CIRP Ann - Manuf Technol* 61:771–791
3. Ramesh R, Mannan MA, Poo AN (2000) Error compensation in machine tools—a review: Part I: geometric, cutting-force induced and fixture-dependent errors. *40:1257–1284*
4. Ramesh R, Mannan MA, Poo AN (2000) Error compensation in machine tools—a review: Part II: thermal errors. *Int J Mach Tools Manuf* 40:1257–1284
5. Postlethwaite SR, Allen JP, Ford DG (1999) Machine tool thermal error reduction - An appraisal. *Proc Inst Mech Eng Part B J Eng Manuf* 213:1–9
6. Jiang H, Fan KG, Yang JG (2014) An improved method for thermally induced positioning errors measurement, modeling, and compensation. *Int J Adv Manuf Technol* 75:1279–1289
7. Cui G, Lu Y, Gao D, Yao YX (2012) A novel error compensation implementing strategy and realizing on Siemens 840D CNC systems. *Int J Adv Manuf Technol* 61:595–608
8. Kim SK, Cho DW (1997) Real-time estimation of temperature distribution in a ball screw system Temperature. *Int J Mach Tools Manuf* 37:451–464
9. Mayr J, Weikert S, Wegener K (2007) Comparing the Thermo-Mechanical-Behavior of Machine Tool Frame Designs Using a FDM-FEA Simulation Approach. *Proc 22nd ASPE Annu Meet* 17–20
10. Zhang T, Ye WH, Liang RJ, Lou PH, Yang XL (2013) Temperature variable optimization for precision machine tool thermal error compensation on optimal threshold. *Chinese J Mech Eng* 26:158–165
11. Lee J-H, Yang S-H (2002) Statistical optimization and assessment of a thermal error model for CNC machine tools. *Int J Mach Tools Manuf* 42:147–155
12. Li YX, Yang JG, Gelvis T, Li YY (2008) Optimization of measuring points for machine tool thermal error based on grey system theory. *Int J Adv Manuf Technol* 35:745–750
13. Yan JY, Yang JG (2009) Application of synthetic grey correlation theory on thermal point optimization for machine tool thermal error compensation. *Int J Adv Manuf Technol* 43:1124–1132
14. Liang RJ, Ye WH, Zhang HH, Yang QF (2012) The thermal error optimization models for CNC machine tools. *Int J Adv Manuf Technol* 63:1167–1176
15. Zhang Y, Yang JG, Jiang H (2012) Machine tool thermal error modeling and prediction by grey neural network. *Int J Adv Manuf Technol* 59:1065–1072
16. Yang H, Ni J (2005) Dynamic neural network modeling for nonlinear, nonstationary machine tool thermally induced error. *Int J Mach Tools Manuf* 45:455–465
17. Han J, Wang LP, Cheng NB, Wang HT (2012) Thermal error modeling of machine tool based on fuzzy c-means cluster analysis and minimal-resource allocating networks. *Int J Adv Manuf Technol* 60:463–472
18. Wang HT, Wang LP, Li TM, Han J (2013) Thermal sensor selection for the thermal error modeling of machine tool based on the fuzzy clustering method. *Int J Adv Manuf Technol* 121–126
19. Abdulshahed AM, Longstaff AP, Fletcher S, Myers A (2015) Thermal error modelling of machine tools based on ANFIS with fuzzy c-means clustering using a thermal imaging camera. *Appl Math Model* 39:1837–1852

20. Lee J, Lee J, Yang S (2001) Development of Thermal Error Model with Minimum Number of Variables Using Fuzzy Logic Strategy. 15:1482–1489
21. Fan ZL, Li ZH, Yang JG (2010) NC machine tool temperature measuring point optimization and thermal error modeling based on partial correlation analysis. *China Mech Eng* 21:2025–2028
22. Chen C, Zhang CY, Chen H (2011) Selection and modeling of temperature variables for the thermal error compensation in servo system. In: *Electron. Meas. Instruments (ICEMI), 2011 10th Int. Conf. on. IEEE.* pp 220–223
23. Liang RJ, Ye WH, Luo W, Yu H, Yang Q (2011) Identification of the key thermal points on machine tools by grouping and optimizing variables. 18:87–93
24. Miao EM, Gong YY, Niu PC, Ji CZ, Chen HD (2013) Robustness of thermal error compensation modeling models of CNC machine tools. *Int J Adv Manuf Technol* 69:2593–2603
25. Yang JG, Deng WG, Ren YQ, Li YS, Dou XL (2004) Grouping Optimization Model ing by Selection of Temperature Variables f or the Thermal Error Compensation on Machine Tools. 6–9
26. Miao EM, Gong YY, Dang LC, Miao JC (2014) Temperature-sensitive point selection of thermal error model of CNC machining center. *Int J Adv Manuf Technol* 74:681–691
27. Zhou ZD, Liu Q, Ai QS, Xu C (2011) Intelligent monitoring and diagnosis for modern mechanical equipment based on the integration of embedded technology and FBGS technology. *Meas J Int Meas Confed* 44:1499–1511
28. Zhou ZD, Jiang DS, Zhang DS (2009) Digital monitoring for heavy duty mechanical equipment based on fiber Bragg grating sensor. *Sci China, Ser E Technol Sci* 52:285–293
29. Deng J L (1989). Introduction to grey system theory. *The Journal of grey system* 1: 1-24