

A smart rail and grid energy management system for increased synergy between DC railway networks & electrical distribution networks

Zangiabadi, Mansoureh; Tian, Zhongbei; Kamel, Tamer; Tricoli, Pietro; Wade, Neal; Pickert, Volker

License:

Other (please specify with Rights Statement)

Document Version

Peer reviewed version

Citation for published version (Harvard):

Zangiabadi, M, Tian, Z, Kamel, T, Tricoli, P, Wade, N & Pickert, V 2021, A smart rail and grid energy management system for increased synergy between DC railway networks & electrical distribution networks. in *2021 56th International Universities Power Engineering Conference (UPEC)*. International Universities Power Engineering Conference (UPEC), Institute of Electrical and Electronics Engineers (IEEE), 56th International Universities Power Engineering Conference, 31/08/21.

[Link to publication on Research at Birmingham portal](#)

Publisher Rights Statement:

© 2021 IEEE. Personal use of this material is permitted. Permission from IEEE must be obtained for all other uses, in any current or future media, including reprinting/republishing this material for advertising or promotional purposes, creating new collective works, for resale or redistribution to servers or lists, or reuse of any copyrighted component of this work in other works.

General rights

Unless a licence is specified above, all rights (including copyright and moral rights) in this document are retained by the authors and/or the copyright holders. The express permission of the copyright holder must be obtained for any use of this material other than for purposes permitted by law.

- Users may freely distribute the URL that is used to identify this publication.
- Users may download and/or print one copy of the publication from the University of Birmingham research portal for the purpose of private study or non-commercial research.
- User may use extracts from the document in line with the concept of 'fair dealing' under the Copyright, Designs and Patents Act 1988 (?)
- Users may not further distribute the material nor use it for the purposes of commercial gain.

Where a licence is displayed above, please note the terms and conditions of the licence govern your use of this document.

When citing, please reference the published version.

Take down policy

While the University of Birmingham exercises care and attention in making items available there are rare occasions when an item has been uploaded in error or has been deemed to be commercially or otherwise sensitive.

If you believe that this is the case for this document, please contact UBIRA@lists.bham.ac.uk providing details and we will remove access to the work immediately and investigate.

A Smart Rail and Grid Energy Management System for increased synergy between DC Railway Networks & Electrical Distribution Networks

Mansoureh Zangiabadi ^a, Zhongbei Tian^b, Tamer Kamel ^c, Pietro Tricoli ^c, Neal Wade ^a, Volker Pickert ^a
a. Newcastle University, UK, b. Liverpool University, UK, c. Birmingham University, UK

Abstract— This paper presents results of the H2020 European E-LOBSTER project which is to propose an innovative Railway to Grid (R +G) Management system, combined with advanced power electronics and storage technologies (the smart Soft Open Point and the electric storage developed in the framework of the project). In particular, the R + G management system will be able to make the best use of the available energy on both grids by increasing their mutual synergies and increasing the energy efficiency of two networks through electric energy storages and at the same time by creating synergy with charging stations for Electric Vehicles (EV). This paper demonstrates an overview of the state of the art of the proposed smart R+G energy management with simulation results of the main case studies as well as an overview smart mobility through Electric Vehicles, charging stations for EVs, e-mobility in general and its synergies with railways.

Keywords— DC Railway Network, Electricity Distribution Network, Electric Vehicles (EV), Energy Management System

I. INTRODUCTION

Energy efficiency is one of the main aims regarding worldwide industry. Considering the weight of transport in terms of energy consumption (over 24% of global CO₂ emissions in 2016 [1]), energy savings in this sector play an important role. EU Commission sets a strong goal towards the transport sector decarbonisation and the role of railways, which is likely to be vital for the future of sustainable transport. The Transport White Paper reinforces this vision with a 60% GHG reduction target by 2050 for transport and sets a path for the energy efficiency of the system [2].

Smart management of railway networks has already been subject of study and several projects have settled indications about its implementation in existing facilities. The origin of the very concept of railway smart management might come from the opportunity that regenerative braking offers. There are several studies that argue the train's capability of energy regeneration is between 30% and 40% of the energy consumed. For several reasons, most of the metropolitan lines there are rheostat consumption losses of around 10-12%, which limits the real savings obtained by regenerative braking [3].

In the technology roadmap "European railway energy roadmap: towards 2030" the European Rail Research Advisory Council stated the importance of developing energy storage and battery technologies for future rail infrastructure. [4-5]. In addition, European organisations have made progress regarding smart management of electric grids, publishing smart grid standards and policies, which are fundamental to foster its implementation in railway infrastructure facilities. In terms of railway operation, smart management systems offer new business opportunities and also add new technical and organisational problems to be tackled. Regarding the business

side, smart management integration into the system means the expansion of the very same railway system, taking into consideration that new actors come into play (management of EV, renewables, energy storage systems, etc.), and, therefore, the entry of new potential business fields, like energy purchasing and integrated transport systems [6]. This potential is based on the fact that railway system will no longer be a passive load, consuming energy from the grid, but it will be part of a larger smart grid and communicate with "non-railway" systems such as smart buildings, electrical vehicles charging station, renewable energy resources, etc. This is in line with the smart grid framework in Europe which is customer-oriented, and the grid is being designed to be flexible, accessible, reliable and economical for customers [7]. This means another important impact of the adoption the concept of smart grids in the railway domain is the increased customer participation. The customer receiving this information is not an individual, but the train operating company. Like smart grids, remote condition monitoring uses automated sensor readings to assess the condition of railway assets. This reduces the need for human inspection and can detect faults before failure, improving safety and reliability. Monitoring of supply and demand may also incentivise operators to implement energy saving measures to reduce consumption and create pressure to incorporate renewables into the electricity mix.

This paper will focus on the new concept of Rail and Grid (R+G) management system developed in E-Lobster project. Two Metro Lines have been simulated and the results have been investigated to analyse and compare the potential braking energy can be used to feed back to grid or to be stored in energy storage. Smart mobility framework has been evaluated in two different case studies as integrated solution of railway and EV uptake in grid. Finally, paper concludes with closing remarks and next step.

II. SIMULATION PLATFORM

This section presents the framework of the two simulators under study: railway and smart-grid simulators developed in MATLAB software [8-9].

A. Numerical railway simulation results of Metro Line

Two Metro Lines of Spanish Urban Metro have been selected for simulation study[8] and results of railway simulator of these two Metro lines have been presented briefly in this section in order to investigate the effect of the headway on the energy consumptions alongside with the energy losses in the railway networks. Additionally, a 24-hour time schedule for both lines has been demonstrated and the energy evaluation have been analysed in such conditions.

Firstly, the following energy equation have been utilized in this section in order to indicate each energy component in the railway network:

$$E_s + E_{braking} = E_{s,loss} + E_{t,loss} + E_{traction} + E_{aux}$$

Where;

- E_s = Supplied energy by the substations to the traction system within the headway time
- $E_{braking}$ = Effective regenerative braking energy available after the braking resistances
- $E_{s,loss}$ = Energy losses of all the substations
- $E_{t,loss}$ = Energy losses of the electrification system (overhead supply and return rails)
- $E_{traction}$ = Drawn energy by all the train to complete the journey
- E_{aux} = Energy consumed by auxiliaries

Besides,

- $E_{braking,available}$ = All available regenerative braking energy from all trains
- η_{regen} = Efficiency of regenerative braking, calculated as $E_{braking} / E_{braking,available} * 100\%$
- $E_{saving\%}$ = Energy Saving percentage by using the effective regenerative braking energy, calculated as $E_{braking} / (E_{braking} + E_s) * 100\%$

The first Metro Line (Line A) under study is 14.031 km with 20 stations and 5 traction substations. The operating voltage of this line is 1500 V DC. The system energy consumptions have been calculated in railway simulator and summarized in Table I for various headway values. This refers to the energy drawn from all the traction substations during train service.

TABLE I- Energy consumption with various headways for Line A

Headway	[s]	120	180	240	300	360	420	480	540	600	660
E_s	[kWh]	257	263	300	259	300	286	317	326	309	292
$E_{s,loss}$	[kWh]	7.7	7.9	9.0	7.8	9.0	8.6	9.5	9.8	9.3	8.8
$E_{t,loss}$	[kWh]	11.0	4.8	8.5	6.3	6.7	6.7	7.0	6.4	7.4	5.9
$E_{traction}$	[kWh]	450	450	450	450	450	450	450	450	450	450
$E_{braking,available}$	[kWh]	273	273	273	273	273	273	273	273	273	273
$E_{braking}$	[kWh]	248	236	204	242	202	216	186	177	194	209
η_{regen}	[%]	91%	86%	75%	89%	74%	79%	68%	65%	71%	76%
E_{aux}	[kWh]	36.1	36.1	36.1	36.1	36.1	36.1	36.1	36.1	36.1	36.1

Fig.1 to Fig.2 illustrate respectively the different energy components in the railway, along with the energy saving and braking efficiency according to the headways. The results show that the energy consumption of the traction system increases when the headway decreases, as there are more trains running simultaneously on the line. In fact, the average power increases from 1.59 MW when the headway is 660 S to 7.71 MW when the headway is 120 S. Similar trend can be identified on power losses, and their impact increases from 5% when the headway is 660 S to 7% when the headway is 120 S.

The losses variation however is different when the headway changes. Clearly, the energy lost in the transmission system increases significantly for shorter headways. This can be explained by the higher regeneration rate when the headway is shorter as less energy is supplied by Traction Power Substation (TPSS) and more energy is exchanged between trains using the electrification network. The energy regenerated by trains increases with respect to the maximum

available braking energy and the efficiency of the regenerative braking increases from 76% when the headway is 660 S to 91% when the headway is 120 S.

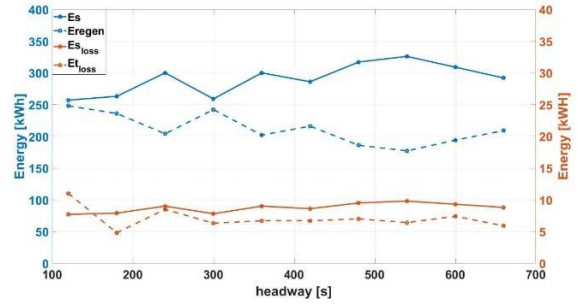

Fig.1- Energy evaluation for line A versus headways

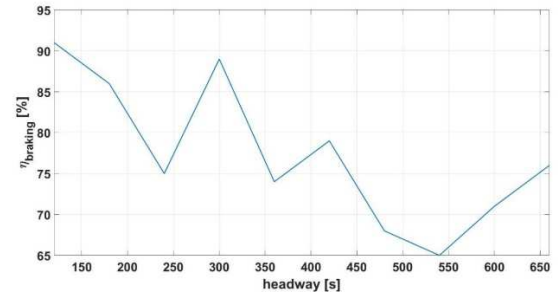

Fig. 2- Braking efficiency (%) for line A versus headways

A 24-hour time schedule is given for Line A, trains are in operation from 6:05 am to 2:00 am with a time period of 19 hours and 55 mins in a working day (Monday to Friday) with the following number of trains in the corresponding headways:

- 191 trains work every 5 mins
- 10 train work every 6 mins
- 8 trains work every 7.5 mins
- 8 trains work every 15 mins

The different energy components in such condition is provided in Table II.

TABLE II. Energy consumption for a whole-day operation for Line A

E_s	[kWh]	57929
$E_{s,loss}$	[kWh]	1738
$E_{t,loss}$	[kWh]	1371
$E_{traction}$	[kWh]	97727
$E_{braking,available}$	[kWh]	59284
$E_{braking}$	[kWh]	50771
η_{regen}	[%]	86%
E_{aux}	[kWh]	7861

The second Metro Line under study (Line B) is a 40.9 km circle line with 28 stations and 11 traction substations. The total journey time is around 60 min. The operating voltage of this line is 1500 V DC. The system energy consumptions within a headway period are summarized in Table III for various headway values. This refers to the energy drawn from all the TPSS during train service. Fig.3 to Fig.4 illustrate respectively the different energy components in the railway,

along with the energy saving and braking efficiency according to the headways. The results show that the energy consumption of the traction system increases when the headway decreases, as there are more trains running simultaneously on Line B. The substation loss is determined by the power from substation, and the transmission loss depends on the power flowing in the network.

TABLE III- Energy consumption with various headways for Line B

Headway	[s]	120	180	240	300	360	420	480	540	600	660
E_s	[kWh]	618	616	616	636	617	643	621	622	656	675
$E_{s,loss}$	[kWh]	18.5	18.5	18.5	19.1	18.5	19.3	18.6	18.7	19.7	20.3
$E_{t,loss}$	[kWh]	12.5	10.7	10.6	12.4	11.7	12.7	12.5	14.4	11.9	13.9
$E_{traction}$	[kWh]	861	861	861	861	861	861	861	861	861	861
$E_{braking,available}$	[kWh]	453	453	453	453	453	453	453	453	453	453
$E_{braking}$	[kWh]	453	453	453	435	453	428	450	451	415	399
η_{regen}	[%]	100%	100%	100%	96%	100%	94%	99%	100%	92%	88%
E_{aux}	[kWh]	178.9	178.9	178.9	178.9	178.9	178.9	178.9	178.9	178.9	178.9

In Line B, the average power increases from 1.02 MW when the headway is 660 S to 5.16 MW when the headway is 120 S. Similar trend can be identified on power losses, but the ratio of the power losses to the respective power consumption is around 5% with various headways. The energy losses vary with the headway changes, but not significantly. When the substation energy supply is high, for example when headway is 660 S, the energy loss is higher. The efficiency of regenerative braking decreases with the headway. In Line B, the efficiency of regeneration braking is high for this route, which is between 88% and 100%. One reason for the high efficiency of this line is that the DC railway network of this line is a long circle line, which allows the regenerative power to flow both sides.

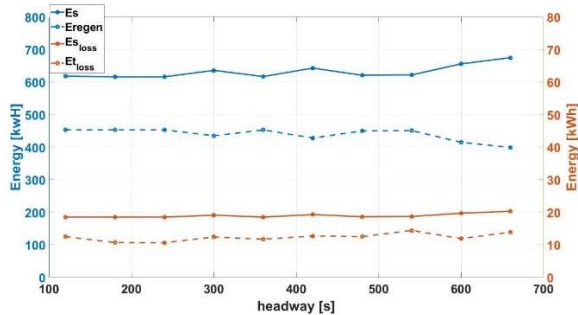

Fig.3- Energy evaluation for line B versus headways

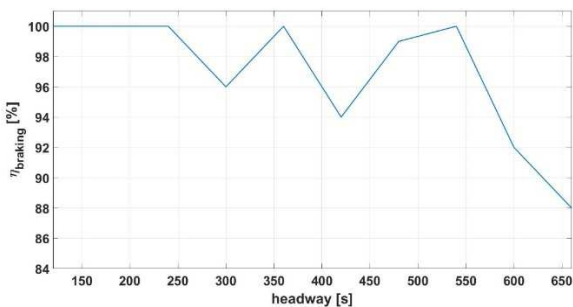

Fig. 4- Braking efficiency (%) for line B versus headways

Finally, a 24-hour time schedule is given for Line B, trains are in operation from 6:05 am to 2:00 am with a time period 19 hours and 55 mins in a working day (Monday to Friday) with the following number of train in the corresponding headways:

- 36 trains work every 6.5 mins

- 112 trains work every 7.5 mins
- 8 trains works every 15 mins

The different energy components in such condition is provided in Table IV.

TABLE IV. Energy consumption for a whole-day operation for Line B

E_s	[kWh]	103920
$E_{s,loss}$	[kWh]	3118
$E_{t,loss}$	[kWh]	2375
$E_{traction}$	[kWh]	134276
$E_{braking,available}$	[kWh]	70645
$E_{braking}$	[kWh]	63951
η_{regen}	[%]	91%
E_{aux}	[kWh]	28087

B. Electrical Distribution Railway Network simulation

In modern railways, the DC traction substations are normally equipped with transformers and rectifiers, drawing electricity from distribution networks. Each traction substation is usually connected to an internal electrical network (for example 15kV in Spain and 11 kV in UK) owned by the metro system operator. Due to the magnitude and variability of the traction load of a metro railway, the connection to the public grid must be at a higher voltage level. Connections to the public grid are therefore made at “Grid Supply Points” and then distributed to the traction substations. The common configuration of electrical railway network with connection to Distribution System Operator (DSO) substations for the metro line under study is illustrated in Fig.5. The whole electrical internal network is fed through 15 kV cables in traction substations and in transformation stations by different cables characteristics as provided in Table V. From point of connection to primary substations of DSO, Metro as qualified customer do not share feeder cables with other customers. In addition, qualified customers as Metro do not usually require a double feed because their own private medium voltage network provides the necessary redundancy. In this typical traction scheme, each TPSS in the internal electrical network has a dual redundancy through two adjacent traction substations in a way that two different DSO substations are never connected to each other. In transformer stations, which are usually located closed to train passenger stations, there are 2 transformers of 15kV to 0.4kV, of which one is connected, and one is in stand-by as a backup. These are the end points of the network.

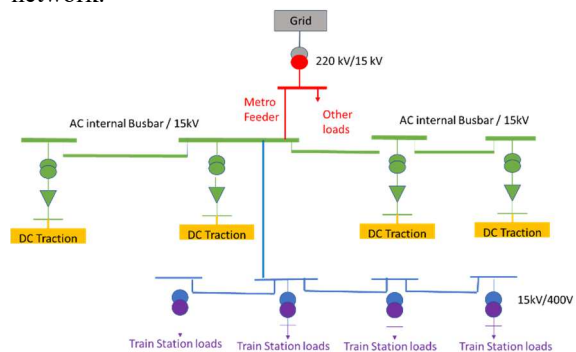

Fig. 5- Common configuration of the metro line under study with metro feeder connection to DSO supply points

TABLE V- Electrical characteristics of the AC cables of Metro internal electrical network

Cable	R(Ω /km)	X(Ω /km)	C(μ F/km)
Red (main metro feeder)	0.0379	0.089	0.84
Green (TPSS feeder)	0.148	0.099	0.56
Blue (Train station feeder)	0.757	0.126	0.3

Consumption in trains is very irregular because they can change rapidly their state as they can be braking or coasting at one moment and motoring at the following instant. Consequently, the power demanded in traction substations (TPSS) is very variable, too. Instant power telemetering samples every 30 sec show clearly the intermittency nature of metro load as box plotted in Fig.6 for a working day for a TPSS substation in Line B. The other traction substations follow the same trend of consumption.

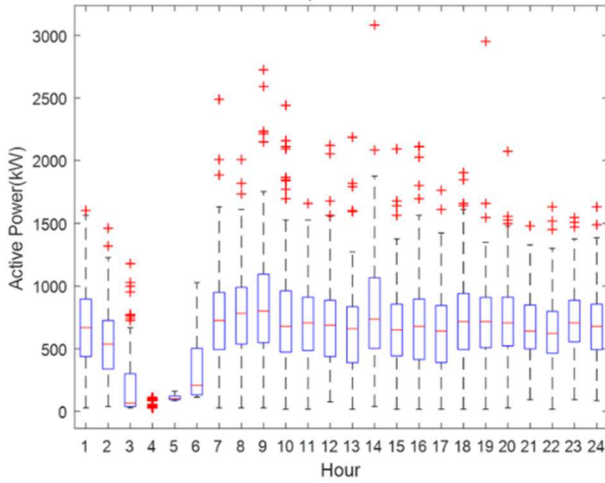

Fig. 6- Boxplot of measured active power consumption of a TPSS in Line B for a working day

The hourly accumulated energy in Fig.7 for one of DSO substation of Line B reveals the pattern of energy usage by trains. The pattern follows up the timetable of train which the peak happening between 7:00 am to 9:00. Based on the time-schedule of Metro, there is no train from 2:30am to 5:30am, so demand is in the minimum in this time schedule. The economic impact associated with energy consumption peaks have a great impact on energy demand charge too.

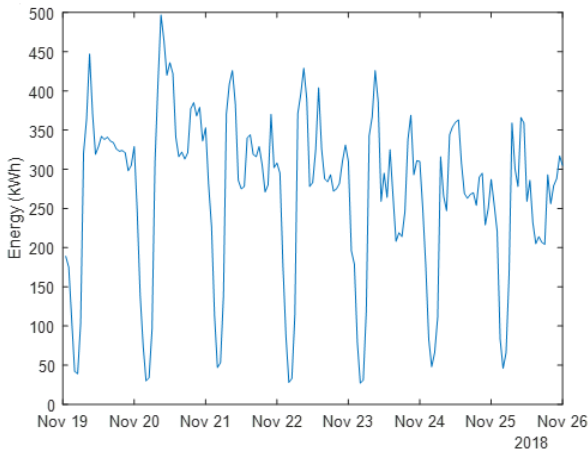

Fig. 7- Hourly accumulated Energy of the same Metro TPSS connected to DSO Substation in Line B

III. E-LOBSTER SOLUTION

With respect to E-LOBSTER, electrical energy storage will play a shared asset between grid and railway. It is a trade-off between electrical grid and railway network which services will be given priority in terms of energy efficiency of whole system. The control strategy will be developed through smart Soft Open Point (sSOP) as the brain of Rail and Grid (R +G) energy management system providing interexchange electricity towards mutual benefits. The concept of E-LOBSTER solution is illustrated in Fig.8. The sSOP with advanced power converters provides recovery of braking energy from the rail system and feeds this energy through a DC link to either the distribution grid or a battery energy storage.

Fig.6 to Fig.7 clearly show, at rush hours, the energy consumption is higher as there are more trains in service however in the same time the regeneration efficiency is higher. Results of railway simulator in Table II and IV show that for headway of 120 S (2 min) the regeneration efficiency is around 91% in Metro Line A and 100% in Metro Line B. In addition, when there are less train running and headway increases for example with headway of 660 S (11 min) which will be at not busy times such as late evening and early morning or at night, the regeneration efficiency will be decreased to 76% for Metro Line A and 88% for Metro Line B, so the braking energy needs to be stored in energy storage to increase the energy efficiency of railway.

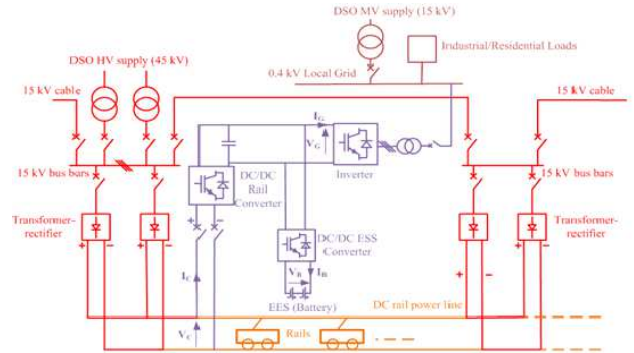

Fig. 8- The concept of E-Lobster Solution

The Rail and Grid (R+G) management system in E-Lobster solution is developed to control sSOP as shown in Fig.9. The R+G management system determines if there is available braking power on the rail network ($P_{\text{Rail-regen}}$) as well as if the LV grid demands power (Grid_{dem}) or if renewable resources generate a surplus energy (Grid_{gen}). There are two operational modes for the sSOP:

- i. **Rail + Grid Mode:** rail provides regenerative braking power to ESS and the LV grid (depending if the LV grid requires power)
- ii. **Grid Mode:** Power is exchanged between ESS and LV grid according to the consumption and generation power levels in the grid side. In this mode there is no available braking power.

The supply of the railway traction from ESS and/or LV grid is not considered here mainly because both ESS and the LV grid have power ratings substantially smaller than that of the trains demand and, hence, would not be capable of providing

an effective contribution. Furthermore, it is unlikely that TPSSs would become overloaded, as they are designed with a reserve capacity of up to three times the nominal ratings to supply the trains in case of faults of one or more TPSSs [10].

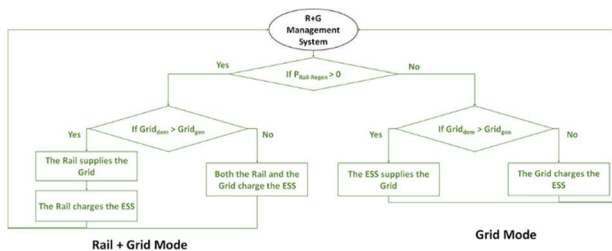

Fig. 9- R+G management system for controlling SOP

IV. SMART MOBILITY SOLUTION

In this section, the synergies and possible ways of integration of electrical vehicles (EV) and E-Lobster solution, are studied. In terms of EV charging platforms, network operators, through their own market research and procurement practices have decided on the type of network they operate and the chargers which operate on it. At a high level, chargers are typically broken into categories based on the speed of recharging they offer – slow, fast and rapid – although as technology advances, ultra-fast chargers are now becoming viable. Regarding the charge speed, there are other factors which come into play depending on the type of car being charged and the charging connector used for example. To put all this information into some context, Fig.10 provides a useful visual indication of the number of driving miles added per minute of charging, depending on the charger ‘type’ or output [11].

The types of chargers installed can also vary depending on the location of the site. Whether it is a motorway services station, a public street or workplace car park or even a home. The slow chargers are becoming redundant in the public space, but they still have a use elsewhere. In many homes and business, it is not feasible to provide fast or rapid charging due to the power demand required. Many people’s vehicles are parked for long periods of time in these locations, typically greater than 8 hours – during the working day or overnight – this makes conditions more promising for a slower charger unit. Smart chargers can be provided with an in-built bidirectional charger, which can be used to provide power flow back to the grid from the EV battery. Another useful function of smart chargers could be their ability to provide load balancing. This is extremely useful in installations with a limited electrical import capacity. This may become prevalent in charging stations providing multiple charging units.

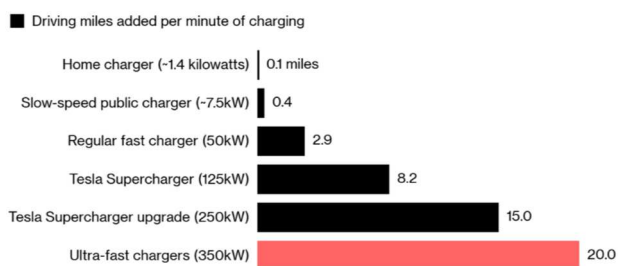

Fig. 10- Driving miles added per minutes of Charging [11]

The Energy storage in E-LOBSTER solution can support grid to accommodate the uptake of EVs with sharing the infrastructure. The braking energy from rail can also be used for EV charging stations. This will open a market for railway operators to the action of selling the energy that comes from train braking to the grid.

The results of rapid EV charging station of a Nissan Leaf (24kWh, 2011 model) demonstrated in Newcastle University Lab is presented in Table VI for two different charging modes [12-13]. Clearly, rapid charging of 80kW will have a considerable increasing demand on distribution grid in a very short time.

TABLE VI
Charge performance testing results

Charge mode	Voltage (V)	Current (A)	Power (kW)	EV battery initial SOC (%)	EV battery final SOC (%)	Time used (mins)
DC level 1	405	52	21	20	80	48
DC level 2	421	192	80	20	80	14

Results of railway simulator for Metro Lines under study presented in Table II and Table IV, reveals the available braking energy not used is $59.284-50.771= 8.513$ MWh for Line A and $70.65-63.95= 6.7$ MWh for Line B in a whole-day operation which can be back to the grid or stored in energy storage or used for charging EVs. If it is considered the average daily energy consumed by a single Nissan-EV in a day can be estimated in 24kWh for guarantying an autonomy of 50-60km on a standard city cycle, then 354 EV in Line A and 279 EVs in Line B can be recharged everyday from the unused braking energy in Metro Lines. If rapid charging of Nissan-EV 40kWh to be considered, then 212 cars in Line A and 167 cars in Line B can be recharged. In addition, energy storage in the E-Lobster solution will be able to support EV rapid charging stations during peak demand of grid. These results are summarized in Table VII.

TABLE VII

Metro Line	Braking energy back to grid (MWh)	Nissan (24kWh)	Nissan (40kWh)
Line A	8.513	354	212
Line B	6.7	279	167

The impact of EV demand on LV grid is also investigated in a case study. The LV grid under study is a residential LV radial network powered from a secondary transformer substation (11kV/433V, 800kVA) and feeding 244 households through five feeders as illustrated in Fig.11. Each feeder has several customers in which 64 customers in Feeder 1; 57 customers in Feeder 2; 60 customers in Feeder 3; 49 customers in Feeder 4 and 14 customers in Feeder 5. A diverse number of customers have also been distributed in each busbar of the feeders in Fig.11. For example, bus-Feeder 2.1 is feeding 11 households and bus-Feeder 3.5 is feeding 9 households, etc. Real time data were acquired from smart meters data collected as half-hourly electrical energy consumption in kWh and then converted to average half-hourly power in kW for analysis [14]. The measurements of EVs involved customers who owned an electric vehicle and had access to a home charger, were being monitored in 143 homes. The EV demand was averaged across all households,

exhibits a significant peak in the evening of about 0.9 kW at around 9:00 pm, broadly equivalent to the house-only consumption peak that occurs at similar time. Like household load, the electric vehicle load drops through the overnight period, but stays around 0.1-0.2 kW during morning and afternoon periods. This behavior in the demand profile is consistent with EVs being used as primary mode of transport, as the owners travel on their electric vehicle during daytime and plug-in it to charge upon returning to home during evening time. However, the peak load during the evening time drops quickly after 10 pm indication that some electric vehicle batteries were fully charged at this point thus reducing the load demand. The load flow results of voltage profile and losses in the network is summarized in Table VIII.

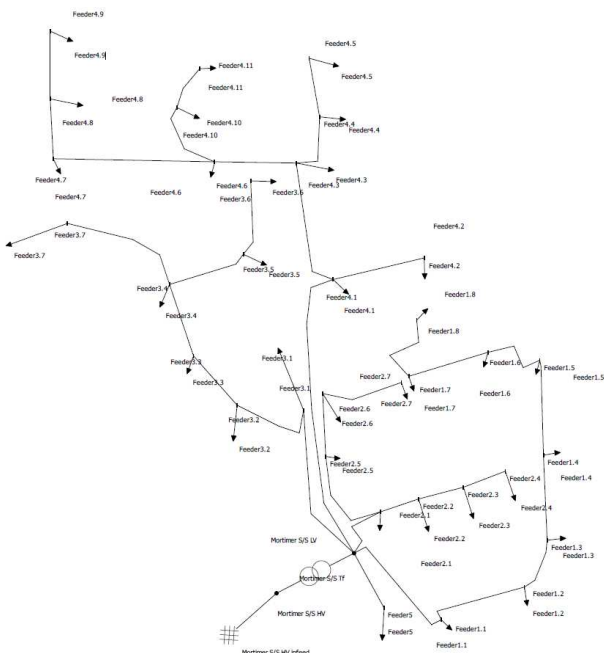

Fig. 11- LV residential Network

TABLE VIII- Summary of results

Summary	Maximum Voltage (pu)	Minimum Voltage (pu)	Maximum of total Losses (kW)	Peak Demand (kW)
Household consumption	1	0.9786	2.3216	226.432
Household consumption +EV	1	0.9587	8.7917	436.516

Results clearly show that in a residential area, where EVs are the primary way of transport, domestic charging of EVs could have a major impact on the network in terms of peak demand and increasing losses in the network. This case study clearly shows that integration of railway and electrical distribution network in E-Lobster solution will support LV grid in different ways in particular through the shared asset of energy storage.

CONCLUSION

As mobility is considered one of the key issues regarding the sustainability of modern cities, the flexibility of transport solutions and a smart integrated approach gain in importance

as a key point. This paper presented obtained results of the E-LOBSTER project which is aiming to provide a Rail & Grid (R+G) management system that uses a new smart soft open point to actively control the flow of energy through the DC railway network and electrical distribution grid. Railways have an enormous potential in the implementation of smart management, considering their advantages of being permanently connected to the electricity grid and interacting with it. Integrated infrastructure systems enable new energy management functions that can bring benefits to the asset owners and operators. The simulation study of Metro Lines showed that not-used barking energy will be a power source to support LV grids in different ways in E-Lobster solution. Results showed E-Lobster solution will support distribution grid to accommodate EV integration within grid to develop smart mobility urban platform concept through integrating two transport systems EVs & Metro. The E-Lobster project is an on-going project and will go through the next steps as the development continues to the demonstration in Lab and real substation environment.

ACKNOWLEDGMENT

E-Lobster project has received funding from the European Union's Horizon 2020 research and innovation program under grant agreement No. 774392. The authors would like to thank Metro de Madrid (MDM) for providing the required data for the Line A & B in order to be simulated in the presented case studies in the paper.

REFERENCES

- [1] IEA (2018). CO2 Emissions from Fuel Combustion 2018 Highlights
- [2] Position paper "The Strategy for long-term EU greenhouse gas emissions reductions", September 2018. CER. Page 1
- [3] D2.2 ' Handbook of the most suitable technologies for electricity losses reduction in DN and Electrified Railway Systems' <https://cordis.europa.eu/project/id/774392/results>
- [4] "Rail 2030: Research and Innovation priorities" ERRAC, 2019.
- [5] http://ec.europa.eu/energy/infrastructure/doc/energy-storage/2013/energy_storage.pdf. 'DG ENER Working Paper: The future role and challenges of Energy Storage' DG Energy, January 2013.
- [6] C. Webb, M. Zangiabadi, R. Palacin, N. Wade, 'Integration of Electric Vehicles and Rail through Park-and-Ride Infrastructure', Proco. 25th international Conference and Exhibition on Electricity Distribution (CIRED2019), Madrid, Spain, 2019, no.(1647), pp.1-5.
- [7] Smart Grid Task Force Mandate. Brussels : European Commission, 2011.
- [8] Z. Tian, T. Kamel and P. Tricoli, "A study to design the locations of reversible traction substations for minimizing power losses of DC railways," 2019 21st European Conference on Power Electronics and Applications (EPE '19 ECCE Europe), Genova, Italy, 2019, pp.1-9.
- [9] Z. Tian, N. Zhao, S. Hillmansen, C. Roberts, T. Dowens, and C. Kerr, "SmartDrive: Traction Energy Optimization and Applications in Rail Systems," IEEE Transactions on Intelligent Transportation Systems (Early Access), DOI: 10.1109/TITS.2019.2897279, 2019.
- [10] Hill, R., "Electric railway traction, Part 3 Traction power supplies", Power Engineering Journal, 1994, pp. 275-286.
- [11] F.Mwasilu et al., 'Electric vehicles and smart grid interaction: A review on vehicle to grid and renewable energy sources integration', Renewable and Sustainable Energy Reviews 34 (2014) 501-516.
- [12] N. Wade, C. Mullen, M. Zangiabadi, M. Feeney, N. Jakeman, 'Smart-Hubs- DC interconnection and management of PV, EV and ESS', Proco. 25th International Conference and Exhibition on Electricity Distribution (CIRED2019), Madrid, Spain, 2019, no.(1334), pp.1-5.
- [13] C. Onwe, M. Zangiabadi, M. Feeney, N. Wade, et al. 'Smart Hubs 1 – A Demonstration of Electric Vehicle's Lithium – Ion Battery Charging Characteristic and Efficient Demand Side Energy Management with Solar Photovoltaic System', Jordan, IREC2021, pp.1-6.
- [14] <http://www.networkrevolution.co.uk/project-library/>