

Converter topologies for MVDC traction transformers

Ferencz, Izsak; Petreus, Dorin; Tricoli, Pietro

License:
Unspecified

Document Version
Peer reviewed version

Citation for published version (Harvard):
Ferencz, I, Petreus, D & Tricoli, P 2020, Converter topologies for MVDC traction transformers. in *2020 IEEE 26th International Symposium for Design and Technology in Electronic Packaging (SIITME)*.

[Link to publication on Research at Birmingham portal](#)

General rights

Unless a licence is specified above, all rights (including copyright and moral rights) in this document are retained by the authors and/or the copyright holders. The express permission of the copyright holder must be obtained for any use of this material other than for purposes permitted by law.

- Users may freely distribute the URL that is used to identify this publication.
- Users may download and/or print one copy of the publication from the University of Birmingham research portal for the purpose of private study or non-commercial research.
- User may use extracts from the document in line with the concept of 'fair dealing' under the Copyright, Designs and Patents Act 1988 (?)
- Users may not further distribute the material nor use it for the purposes of commercial gain.

Where a licence is displayed above, please note the terms and conditions of the licence govern your use of this document.

When citing, please reference the published version.

Take down policy

While the University of Birmingham exercises care and attention in making items available there are rare occasions when an item has been uploaded in error or has been deemed to be commercially or otherwise sensitive.

If you believe that this is the case for this document, please contact UBIRA@lists.bham.ac.uk providing details and we will remove access to the work immediately and investigate.

Converter topologies for MVDC traction transformers

Izsák Ferencz, Dorin Petreuş
Department of Applied Electronics
Technical University of Cluj-Napoca
Cluj-Napoca, Romania
izsak.ferencz@ael.utcluj.ro

Pietro Tricoli
Department of Electronic, Electrical and Systems Engineering
University of Birmingham
Birmingham, United Kingdom
p.tricoli@bham.ac.uk

Abstract— The paper compares the conventional railway traction systems with new traction systems proposed and developed in the last decade that are also suitable for the medium voltage DC (MVDC) railway electrification concept presented in this project. Differences and requirements of the MVDC traction system will be considered while investigating converter topologies for MVDC transformers (Power Electronic Traction Transformers – PETTs or Solid State Transformers – SSTs). Then, the paper will focus on presenting the most suitable DC-DC converters for this application, defining an example of optimal configuration and requirements of control, which in the future can be further developed for a novel MVDC railway electrification’s traction systems on-board.

Keywords – *phase-shift converter, RDC snubber, active snubber, battery charger*

I. INTRODUCTION

The reason behind railway electrification (RE) was the reduction of operating costs, CO₂ emissions and an improvement in energy efficiency. The newly developed electric locomotives (EL) achieved more power than diesel engines, while showing better reliability. High power EL can also pull heavier freight at higher speed over slopes, thus increasing capacity in mixed traffic conditions. Having no local emissions, electric propulsion has a great advantage over diesel in urban areas as well. In the past decade, RE constantly increased and the account of electrified tracks almost reached one third of the total tracks globally by the year 2012. According to a report of the International Energy Agency, between 1990 and 2015 due to the increase of RE both the energy consumption per transport unit decreased and the CO₂ emissions per transport unit decreased by 35.8% and 31.6% respectively. Moreover, half of these reductions were achieved in the decade of 2005 to 2015: rail energy consumption per passenger-km decreased by 27.8% and energy consumption per freight tonne-km decreased by 18.1%; rail CO₂ emissions per passenger-km decreased by 21.7% and CO₂ emissions per freight tonne-km decreased by 19.0%. In this time, the share of oil products decreased from 62.2% to 56% in the global railway fuel mix, while the share of electricity increased, whereof electricity generated by renewables has shown an increase of 65% [1]. The data presented in these reports points to the future tendency of integration of renewables in the railway electrification system (RES) and to the necessity of innovation and better compatibility between them.

However, electrification of new and existing railway lines have required a substantial investment for the railway

infrastructure. This is because RE uses AC single-phase power that requires connection to high-voltage transmission lines, which are not always available in places where the railway feeder stations should be located and usually require complicated and extremely expensive modifications of the existing layouts, i.e. tap and looped connections of the substations. Moreover, the typical power level of heavy trains or even high-speed trains is compatible with the typical capabilities of medium-voltage (MV) distribution systems. On the other hand, the connection of railway feeder stations to the power distribution network (PDN) would be possible only with the condition not to introduce any imbalance into the system. In contrast to the single-phase AC electrification system, DC systems satisfy this requirement, however, the level of the DC voltage is limited to around 3kV because of the limitation on the maximum short-circuit breaking current of circuit breakers, which in turn limits the maximum power of the railway. Additionally, a higher voltage of the power supply would pose problems for the traction system of the trains, which operates at voltage levels of few kV. Besides, the traditional concept of DC railways does not fit very well with the future vision of electric railway better integrated with the PDNs. The most promising concept is a smart interoperable electric railway grid including green energy plants. The aim of MVDC Electric Railway Systems (MVDC-ERS) project is to propose a new type of MVDC traction power supply based on controlled bidirectional converters to improve the connectivity of the railway to the grid and to integrate renewable power sources to the RES. This would not only improve the efficiency of the railway supply, but it will give additional capacity to the power distribution grid, as railway electrification lines could be used to provide extra capacity between the nodes where the substations are connected. This would be especially important for future scenarios where a higher proportion of renewable energy sources will be introduced in the power system and the control of the power flow will be vital to maintain the correct functionality of the power system. [2], [3], [4].

This paper has four main sections. This first section presents the context and the issues to be solved. The second section contains a detailed comparison between MVDC and MVAC RESs including traction. The third part analyses different PETT topologies to define the suitable one for MVDC traction. The penultimate section represents the simulation model and results for the proposed MVDC traction configuration, while the last section includes observations and conclusions.

II. MVDC-ERS COMPARED TO MVAC-ERS

At the moment, modern RESs use AC to produce higher voltages using transformers. For the same amount of power, the higher the voltage the lower the current. Having lower currents, the line losses are reduced, and higher power can be delivered. The earliest systems choose DC because at that time, AC was not understood well and good insulator materials for such high voltages were not available. However, the DC equipment was massive high currents being implied to obtain enough power for the low voltage locomotives (first at 600 V and then 1500 VDC). These high currents lead to large transmission losses. Areas like Eastern Europe, where catenaries operate at 3kV DC, two 1500VDC motors in series are used, but even at 3kV to power a heavy train the currents needed can be excessive. Later AC motors became predominant as they developed, used on longer routes. The higher voltages of tens of thousands allowed the use of low currents and losses could be minimized meaning cheaper wires. Such high voltages could not be used with DC locomotives due to the difficulty of the voltage/current transformation in a so efficient way as AC transformers. Now better semiconductor devices being available, DC lines are still used and under development. Both RESs converts and transports high-voltage AC from the grid to lower voltage DC in the locomotive, the difference between the two RESs is the location where the conversion from AC to DC is done: at the feeding substation (in case of DC) or on the locomotive (AC). The choice of which one to be used, often depends on the already existing RES in the respective country or area and the costs of a new infrastructure.

PETTs are popular in applications where power density and high efficiency are targeted, therefore it is highly researched for traction applications in electric railways and ships. Fig. 1 illustrates the concept of a PETT, as the LFT is replaced by an MFT as part of the chosen topology. With a higher operating frequency, MFTs achieve a reduced volume and weight at the same winding current density and maximum magnetic field strength, as the induced voltage is proportional to frequency. Additional features of PETTs include control of input and output voltages and currents, the flow of power and load protection.

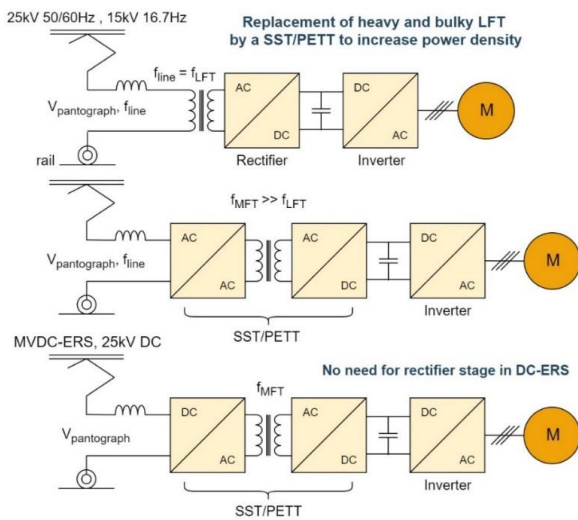

Fig. 1. PETT replacing traditional LFTs and the difference between currently used MVAC-ERS and the MVDC-ERS.

To illustrate this, let's take the example of 15kV/16.7Hz ERS: ABB reported a system weight and volume reduction of 50% and 20% respectively applying only a 400Hz PETT instead of the LFT system [5]. With the appearance of low-floor vehicles or roof mounted traction equipment as well as higher power demand in the case of high-speed trains, the features offered by PETT technology are highly attractive. Fig. 2 summarizes the advantages of MFT technology used in PETTs as the new traction transformer tendency.

	LFT	MFT
Power density	low	high
Efficiency	limited and lower	high
Transformer design complexity	low	high, moreover different applications need different and specific design
Operating/switching frequency	line frequency (low)	hundreds of Hz to tens of kHz
Power quality	fair	good, due to more control options
Technical maturity	reached its maturity	not yet mature, some topologies and configurations are reaching their potential faster than others
Fault current limitation	low	good
Fault isolation capability	poor	good, also redundant configuration is available
Control complexity	low	high and in some applications can be difficult, but rewarding
Switch and drives count	low	high number of devices, due to modular/multi-level structure, however WBG high-voltage devices can lower it
Flexibility	low	high, offers additional functionalities like fault limitation and isolation, voltage flicker compensation
Controllability	low, no control over transmitted power	high, good control over power flow
Availability	high	fair, difficult to design and manufacture
Reliability	high	lower; under research and development, different configurations, like redundancy can bring improvements
Costs	low cost compared to state of the art technologies, much better kW/cost value	due to multilevel/multi-stage and/or multi-modular structure they have a higher cost (still low kW/cost value)
Losses	higher losses	lower losses

Fig. 2. Advantages of MFT technology over LFT in current RESs.

In table I, the most widely used AC RES – 25kV, 50/60Hz ([6]) – will be analyzed in comparison with the novel MVDC RES, in terms of: power supply system technology, number of connections to utility grid, substation interaction, current feeding back to the grid, overhead lines, current transportation, rolling stock, power fed back to the overhead line through braking and current return, corrosion and leaks. Regarding DC RES, most of the drawbacks of LVDC systems are caused by having low voltage, implying higher number of substations, heavier overhead lines and higher traction losses. Due to the higher current, corrosion should also be considered. Because of these, current DC systems are not economical regarding overhead lines – implying higher investments and operational costs (tear and wear) – and regarding substations – higher number meaning more expensive connections to the grid and higher maintenance costs.

TABLE I. MVAC AND MVDC RAILWAY ELECTRIFICATION SYSTEM – COMPARISON WITH ADVANTAGES AND DISADVANTAGES

	25 kV 50/60Hz AC	MVDC-ERS
Utility/main grid (power supply)	<ul style="list-style-type: none"> – possible unbalance on the utility grid – strong electric connections needed + medium to low number of connections (depending on substation technology if it is transformer or converter based) 	<ul style="list-style-type: none"> + low impact and no unbalances on the grid + low number of connections to the grid + possible connection to weaker parts of the utility grid + possibility to develop smart grids
Substation	<ul style="list-style-type: none"> + low number of substations, meaning lower investments and maintenance costs + simple circuit breakers and switching devices + simple fault detection – in case of using converters, two conversion stages AC/DC/AC to solve unbalanced loading, larger substation (need of land) 	<ul style="list-style-type: none"> + fewer substations (no inductive voltage drop, allows more distance between substations) meaning lower investments and maintenance costs + bilateral supply, substations can be paralleled to share the load + Possibility of controlling DC short circuit currents by substation converters and using low-load or no-load DC circuit breakers + only one conversion stage, thus improved efficiency and smaller substation
Interactions in substations	<ul style="list-style-type: none"> – complex power supply diagram due to phase separation – less flexibility in case of substation incident 	<ul style="list-style-type: none"> + simple power supply diagram since there is no phase separation, beneficial in dense areas of traffic + substations in parallel flexible in case of incident
Current fed back to the utility grid	<ul style="list-style-type: none"> + basic transformers needed to feed back currents to overhead line, or the two stage AC-DC-AC converters could also be used 	<ul style="list-style-type: none"> +/- inverters needed with harmonics generated, but power factor of AC-DC converter and harmonics injected to the grid can be controlled to meet standards
Overhead line and current transportation	<ul style="list-style-type: none"> – high insulation distances, thus difficult implementation in urban areas and tunnels – complex impedance $j\omega L$, therefore presence of inductive voltage drops + low losses due to high voltage in traction circuit + light overhead line due to lower current: lower costs and higher speeds + low tear & wear of contact wire + one contact wire – neutral zones 	<ul style="list-style-type: none"> – high insulation distances, thus difficult implementation in urban areas and tunnels + absence of $j\omega L$ part, thus no inductive voltage drops and reactive power consumption + low losses (high voltage) and light overhead line due to lower current + no skin effect, thus smaller cross-sections; light overhead line due to lower current: lower investments + low tear & wear of contact wire, low maintenance costs + no neutral sections, avoiding power transfer interruptions and speed loss as well as mechanical and electrical stresses in locomotive circuit breakers
Rolling stock	<ul style="list-style-type: none"> – large and heavy transformers on-board, thus heavy rolling stock – need of rectifiers on-board + simple circuit breakers – converter complexity and reliability 	<ul style="list-style-type: none"> + smaller PETTs on-board, thus lighter rolling stock + no rectifier on-board, thus lighter and more reliable rolling stock – converter complexity and reliability, complex circuit breakers, current has to be controlled and limited in faults in on-board PETTs – need of rolling stock development
Regenerative braking	<ul style="list-style-type: none"> – necessity to adjust the phase of the current with overhead line current 	<ul style="list-style-type: none"> + no adjustments of the phase of the feedback current is needed
Current return	<ul style="list-style-type: none"> + low levels of current returning to substations due to high voltage 	<ul style="list-style-type: none"> + lower levels of current returning to substations due to high voltage, but the new system must be able to mitigate stray currents
Corrosion and leaks	<ul style="list-style-type: none"> + low risk of corrosion due to low current leaks 	<ul style="list-style-type: none"> + limited corrosion due to lower return currents
Interferences	<ul style="list-style-type: none"> – ground currents may interfere with communication devices near the railway installations and when power electronics are used – large filters and compensators needed to improve power quality 	<ul style="list-style-type: none"> +/- possible interference with signaling systems, no induced voltages in adjacent lines – high power converters may produce high order harmonics – EMI, EMC noise emissions have to be investigated
Conclusions	<ul style="list-style-type: none"> Allows more powerful traffic if well dimensioned. 	<ul style="list-style-type: none"> Will combine advantages of current AC and DC systems, (most drawbacks in current DC systems are due to low voltage), however new operation procedures and regulations are needed.

As Table I summarize, a new MVDC-ERS is a promising project, since it combines the advantages of the current MVAC and LVDC ERSs and at the same time opening new opportunities for the design of future smart grids. This will imply new areas of study and some aspects presented in table 1 need more research and investigations. Some examples are the faults detection in real time, new circuit breakers for HVDC in substations as well as in PETTs on-board in rolling stocks, insulating materials, overhead line

design, flexible power-supply diagrams, necessary modifications in rolling stocks for compatibility, the impact of high DC voltage on current collection. Several studies like [7] have shown environmental, and system stability benefits of High Voltage DC (HDVC) transmission lines. In the case of DC train systems potential cost savings, complexity of infrastructure and more friendly integration into the grid are highlighted as further advantages in [8], [9], [3],[10].

III. MVDC TRACTION

A. Topological Overview

The new wide band-gap semiconductor materials like silicon carbide (SiC) encourages PETT development, especially when the 6.5kV and 10kV and later 15kV SiC components will be ready to be commercialized. SiC semiconductors allow switching frequencies as high as tens of kilohertz. Due to this advantage the switching frequency of MFTs could be increased and when SiC devices will appear at higher voltages it will also allow to use fewer converter modules and/or stages. A new ERS such as a flexible MVDC-ERS requires high-performance, novel PETT structures to handle new challenges such as fault handling, protection circuits and smart-grid compatibility. In the MVDC-ERS concept the setup looks different in comparison to the main topological families defined in state of the art literature, since a rectifier stage is not needed in MVDC traction topologies. This will further improve efficiency and power density. However, to improve the new MVDC line-based traction devices voltage balancing stages (VBS) could be used instead of the rectifier stages.

This section will present an overview of different PETT topologies developed in the last three decades, presenting the trends. However, the present study will focus only on MV PETTs (15kV and 25kV AC ERSs), since currently all state of the art MV PETTs are developed for AC ERSs.

The topology on Fig. 3 was developed by Weiss in '85 as the first ever PETT for railway applications. It consisted of a matrix converter and 400Hz MFT. Later the concept was further studied and the newly available IGBTs of high voltage were employed. Currently it is efficiently applicable to LV systems. Its advantages are: higher switching frequency, lower losses, less modules and costs with a future potential, when the 10-15kV SiC transistors will appear. However the design for reliability is challenging (not having redundancy) or increases complexity.

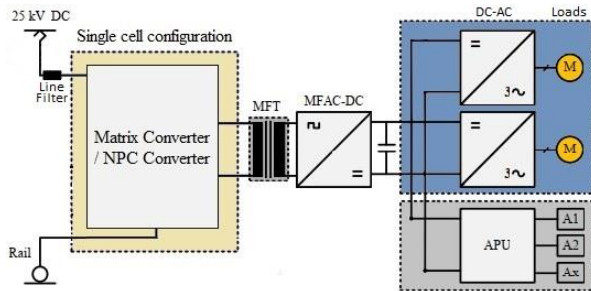

Fig. 3. Single cell matrix/NPC based PETT for MVDC traction. (APU means Auxiliary Power Unit and M is Motor).

In 2001 researches demonstrated the necessity of series connection of converters in the front end. Right after, in 2002, the multi-cell concept was presented, see Fig. 4. During 2003-2005 Siemens also developed such a system of 2MVA power. This topology is scalable to higher voltages, it is reliable (redundant cells), and it has dynamic voltage sharing capability. A single MFT can be an advantage and a disadvantage too in some situations, moreover having many stages and levels increases costs and control can be more difficult.

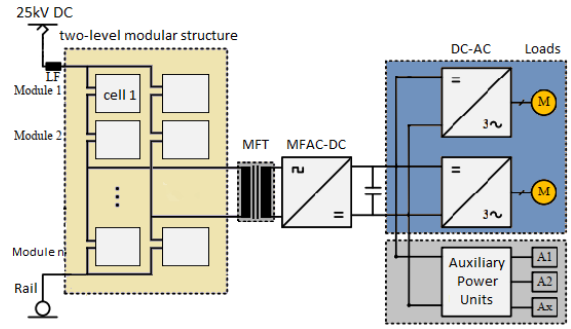

Fig. 4. Multi-cell (modular multi-level) PETT topology.

Currently the most commonly used converter configuration is the input-series output-parallel (ISOP). In 2003 Alstom developed a converter with semi-separated multi-winding transformer, as in Fig. 5, usable for electric-multiple-units (EMU) setup with independent output DC links in secondary. The advantages of this topology was the balanced power distribution between modules, it became mature and popular and the modular design is fully controllable. However, the joint multi-winding MFT is difficult to make and it has weaker fault-handling capability. Regarding the more advantageous ISOP setup, it is a compromise, since increases control complexity.

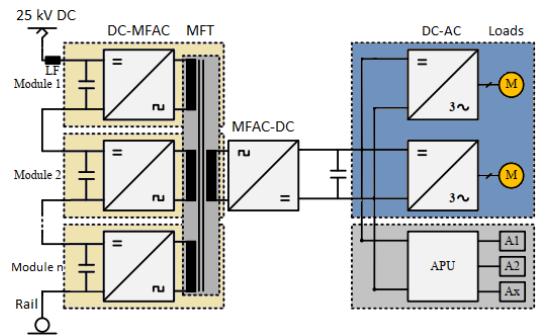

Fig. 5. Cascaded ISOP setup with semi separated multi-winding isolation (SSMW).

In 2014 a similar configuration as the previous one was developed in China, but with multi-port configuration in the secondary as a novelty. It is usable in 25kV ERSs. Similar to the previous topology, voltage-balancing control is achievable and as a plus more ports are available. Its disadvantages is the joint multi-winding MFT, which is difficult to make and has weaker fault-handling capability.

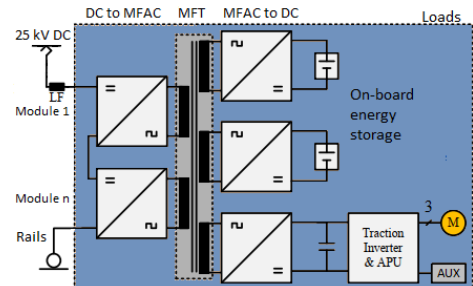

Fig. 6. Multi port multi-winding PETT configuration.

Currently the most preferred topological family is the one on Fig. 7. It is mostly proposed for 15kV ERS, and since 25kV is a higher voltage by 66% than 15kV, it implies more cascaded modules (high number of power devices) and higher costs, when applied to a 25kV ERS. The whole

system is ISOP structure, fully controllable and with improved reliability due to separated windings, currently is the most popular and mature topology, the transformer is less difficult to produce and has better fault handling capability.

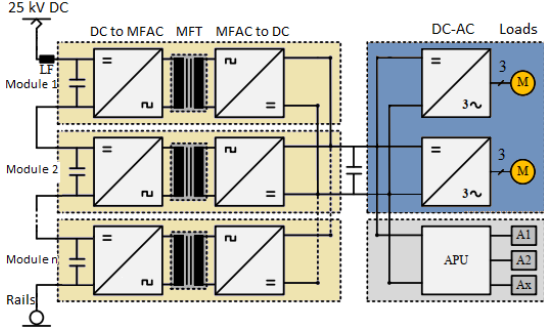

Fig. 7. Cascaded ISOP setup with separated multi-winding (SMW) isolation.

ABB developed the first ever PETT implemented into an actual locomotive and then tested in 2011 on the Swiss Federal Railways [11]. It was a half-bridge topology. Asymmetrical active H bridge topologies include different LLCs, Phase-Shifts and other suitable configurations for modular applications. They work well in different projects depending on each application requirement. Other projects presented full-bridge topologies also, up to 3MVA. In [12] it is highlighted, that CHB configurations are more mature and can reach higher voltages than other state of the art multilevel topologies, including diode-clamped configurations, which can have higher switching losses and unbalanced voltage.

The CHB and the matrix converters are the two preferred candidates for front-end converters, with CHB systems more mature and popular. In terms of the transformer, the multi-separated MFTs configuration is better than joint multi-winding configuration, because it is easier to manufacture and has better fault handling performance. In terms of the system configuration, cascaded front-end (CFE) converters with fully controllable power electronic devices must be used, in order to withstand the input voltage from the catenary. ISOP is the most popular, as it uses a modular design that is good for redundancy. However, they have the disadvantages of high cost and low-power density necessity, thus topologies with reduced number of CFE converters would ultimately be preferred when new semiconductors with higher blocking voltage will become available.

As a conclusion for the MVDC-ERS project the most suitable topology is the one in Fig. 7 with an H Bridge as the converter stage using the latest SiC technology and MFT above 20 kHz. The example presented in this paper is a MVDC Dual Active Bridge (DAB) traction converter with.

B. Specifications

The specifications of the MVDC RES catenary voltage are: Lowest permanent voltage 19kVDC, Nominal voltage 25kVDC, and highest permanent voltage 27.5kVDC. On this range (19-27.5kV) the total power factor λ (active power /apparent power) must be:

$$\begin{cases} \lambda \geq 0.95, & \text{if } P_{pant} > 2MW \\ \lambda > 0.85, & \text{if } P_{pant} < 2MW \end{cases} \quad (1)$$

,where P_{pant} is the instantaneous power at the pantograph. In the cases when this power is below 2 MW, the overall (traction and auxiliaries) average power factor must be greater than 0.85 over a complete timetabled journey [13].

$$\lambda = \frac{1}{\sqrt{1 + \left(\frac{W_Q}{W_P}\right)^2}} \quad (2)$$

Equation 2 presents the calculation of the overall average λ for a train journey, including stops as a function of active (WP in MWh) and reactive energy (WQ in MAh).

Inside yards and depots, when traction power is switched off but all auxiliaries are still running and the power drawn is greater than 200 kW, the power factor should be ≥ 0.8 . During regenerative braking the power factor can decrease freely to keep the voltage within limits. Capacitive power factor of a train is not limited, since a train should not behave as a capacitor, however during regenerative mode if there is capacitive power, it shall be limited to 150kvar on the range 19-27.5kV.

Each train should have automatic regulation device, which in case of weaker network or abnormal operation adapt the level of maximum power consumption depending on the contact line voltage in steady state. Therefore, power selection devices must be installed, which can limit the power demand to the electrical capacity of the line. According to standard EN 50388 from 2012, the maximum allowable current on classical lines is 800A and 500 to 1500A on HS TSI (High-Speed Technical Specifications for Interoperability) lines, in the case of the 25kV AC ERS.

IV. SIMULATIONS AND RESULTS

The simulation model of the proposed MVDC PETT was implemented in Matlab/Simulink and Powersim too. Fig. 7 on the left shows one DAB module and on the right 8 modules in ISOP setup. In Fig. 9 the PETT module's waveforms can be seen. The values of maximum primary current and voltage depends on how the converter is designed.

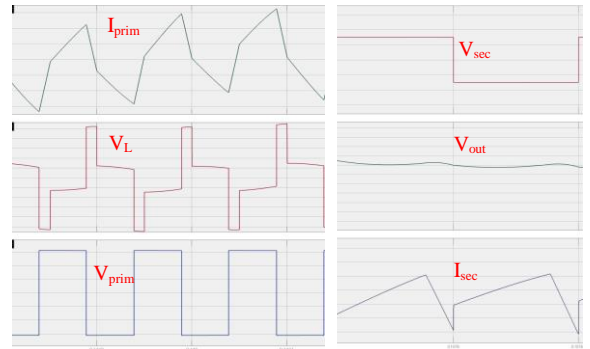

Fig. 9. DAB module results. Primary and secondary waveforms.

The design parameters depends on the maximum train current allowed and the maximum voltage and current of the SiC devices used. This can vary the number of modules too.

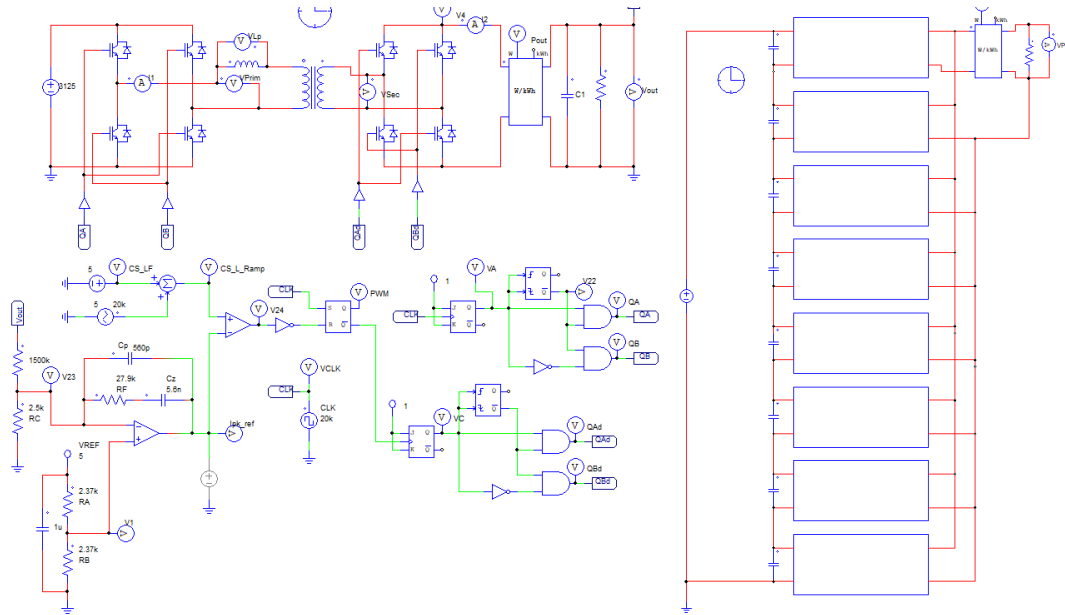

Fig. 8. The schematic of the phase-shift converter. The snubber circuits in shaded areas are tested separately.

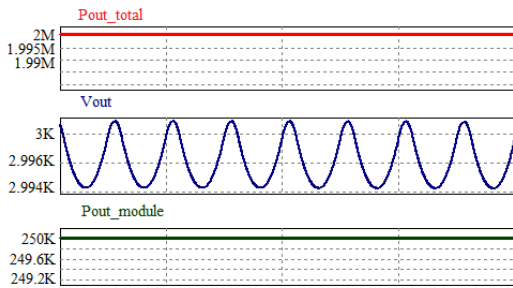

Fig. 9. MVDC PETT System example – 8 modules waveforms.

In this example the following parameters were used: 20kHz switching frequency, 25kV input voltage, 3kV output voltage, 2MW maximum total and 250kW module power.

V. CONCLUSIONS

As a conclusion, it is important to notice that the benefits of modern PETTs are evident - firstly, the improved efficiency and power quality, secondly a redundant design, which improves availability, and thirdly the increased power density, while most drawbacks are technology and material dependent and the development of power devices and materials, as well as investigation of topologies and control methods will probably mitigate most of them. MVDC-ERS presents a concept based on various new technology that makes possible its implementation. Such a novel system will open new opportunities and functionalities of an interoperable smart DC grid. At the same time the new system will combine the advantages of current ERSs. The on-board PETTs will have to be redefined also for the new system and its needs.

ACKNOWLEDGMENT

This project has received funding from the Shift2Rail Joint Undertaking (JU) under grant agreement No 826238. The JU receives support from the European Union's Horizon 2020 research and innovation programme and the Shift2Rail JU members other than the Union.

REFERENCES

- [1] International Energy Agency, "Railway Handbook 2017."
- [2] M. Brenna, F. Foiadelli, and D. Zaninelli, *Electrical railway transportation systems*. Wiley, 2018.
- [3] A. Verdicchio, P. Ladoux, H. Caron, and S. Sanchez, "Future DC Railway Electrification System - Go for 9 kV," *2018 IEEE Int. Conf. Electr. Syst. Aircraft, Railw. Sh. Propuls. Road Veh. Int. Transp. Electrification Conf.*, pp. 1–5, 2019, doi: 10.1109/esars-itec.2018.8607304.
- [4] L. Peng, S. Wang, L. Xu, Z. Zheng, and Y. LI, "Onboard DC Solid State Transformer Based on Series Resonant Dual Active Bridge Converter," *2018 IEEE Int. Conf. Electr. Syst. Aircraft, Railw. Sh. Propuls. Road Veh. Int. Transp. Electrification Conf.*, pp. 1–6, 2019, doi: 10.1109/esars-itec.2018.8607334.
- [5] N. Hugo, P. Stefanutti, M. Pellerin, and R. Sablières, "Power Electronics Traction Transformer," *Proc. Eur. Conf. Power Electron. Appl.*, pp. 1–10, 2007.
- [6] *EN 50163: Railway applications. Supply voltages of traction systems*. 2007.
- [7] K. Meah and S. Ula, "Comparative evaluation of HVDC and HVAC," *Proc. IEEE Power Eng. Soc. Gen. Meet.*, pp. 1–5, 2007.
- [8] A. Gomez-Exposito, J. M. Mauricio, and J. M. Maza-Ortega, "VSC-Based MVDC railway electrification system," *IEEE Trans. Power Deliv.*, vol. 29, no. 1, pp. 422–431, 2014, doi: 10.1109/TPWRD.2013.2268692.
- [9] A. Verdicchio, P. Ladoux, H. Caron, and C. Courtois, "New Medium-Voltage DC Railway Electrification System," *IEEE Trans. Transp. Electrification*, vol. 4, no. 2, pp. 591–604, 2018, doi: 10.1109/TTE.2018.2826780.
- [10] H. Shigeeda, H. Morimoto, K. Ito, T. Fujii, and N. Morishima, "Feeding-loss Reduction by Higher-voltage DC Railway Feeding System with DC-to-DC Converter," *2018 Int. Power Electron. Conf. (IPEC-Niigata 2018 -ECCE Asia)*, pp. 2540–2546, 2018, doi: 10.23919/IPEC.2018.8507567.
- [11] M. Claesens, D. Dujic, F. Canales, J. K. Steinke, P. Stefanutti, and C. Veterli, "Traction transformation: A power-electronic traction transformer (PETT)," *ABB Rev.*, no. 1, pp. 11–17, 2012.
- [12] L. Heinemann, "An actively cooled high power, high frequency transformer with high insulation capability," *Conf. Proc. - IEEE Appl. Power Electron. Conf. Expo. - APEC*, vol. 1, no. c, pp. 352–357, 2002, doi: 10.1109/apec.2002.989270.
- [13] European Committee for Electrotechnical Standardization, "Railway Applications - Power supply and rolling stock - Technical criteria for the coordination between power supply (substation) and rolling stock to achieve interoperability," 2013.