

## Investigating the relationship between trenching practice and road deterioration using a field trial

Eskandari Torbaghan, Mehran; Curioni, Giulio; Hayati, Farzad; Royal, Alexander; Chapman, David; Atkins, Philip; Rogers, Chris

DOI:

[10.1680/jinam.19.00052](https://doi.org/10.1680/jinam.19.00052)

License:

None: All rights reserved

*Document Version*

Peer reviewed version

*Citation for published version (Harvard):*

Eskandari Torbaghan, M, Curioni, G, Hayati, F, Royal, A, Chapman, D, Atkins, P & Rogers, C 2020, 'Investigating the relationship between trenching practice and road deterioration using a field trial', *Infrastructure Asset Management*. <https://doi.org/10.1680/jinam.19.00052>

[Link to publication on Research at Birmingham portal](#)

### General rights

Unless a licence is specified above, all rights (including copyright and moral rights) in this document are retained by the authors and/or the copyright holders. The express permission of the copyright holder must be obtained for any use of this material other than for purposes permitted by law.

- Users may freely distribute the URL that is used to identify this publication.
- Users may download and/or print one copy of the publication from the University of Birmingham research portal for the purpose of private study or non-commercial research.
- User may use extracts from the document in line with the concept of 'fair dealing' under the Copyright, Designs and Patents Act 1988 (?)
- Users may not further distribute the material nor use it for the purposes of commercial gain.

Where a licence is displayed above, please note the terms and conditions of the licence govern your use of this document.

When citing, please reference the published version.

### Take down policy

While the University of Birmingham exercises care and attention in making items available there are rare occasions when an item has been uploaded in error or has been deemed to be commercially or otherwise sensitive.

If you believe that this is the case for this document, please contact [UBIRA@lists.bham.ac.uk](mailto:UBIRA@lists.bham.ac.uk) providing details and we will remove access to the work immediately and investigate.

**Title: Investigating the relationship between Trenching Practice and Road Deterioration using a Field Trial**

Author 1 (Corresponding author)

- **Given name:** Mehran **Family name:** Eskandari Torbaghan, MSc, PhD. Research Fellow
- School of Engineering, Department of Civil Engineering, College of Engineering and Physical Sciences, University of Birmingham, Birmingham, B15 2TT, UK, Tel.: +44 121 414 4166, E-Mail: M.eskandaritorbaghan@bham.ac.uk

Author 2

- **Given name:** Giulio. **Family name:** Curioni, Research Fellow, BSc, MSc, PhD, M.I. Soil Sci.
- School of Engineering, Department of Civil Engineering, College of Engineering and Physical Sciences, University of Birmingham, Birmingham, B15 2TT, UK, Email: G.Curioni@bham.ac.uk

Author 3

- **Given name:** Farzad **Family name:** Hayati, Research Fellow, BSc (Hons), PhD, MInstP, MIET, MIEEE
- School of Engineering, Department of Engineering, Electronic, Electrical and Computer Engineering, College of Engineering and Physical Sciences, University of Birmingham, Birmingham, B15 2TT, UK, Email: f.hayati@bham.ac.uk

Author 4

- **Given name:** Alexander C. D. **Family name:** Royal, MEng, PhD. Lecturer
- School of Engineering, Department of Civil Engineering, College of Engineering and Physical Sciences, University of Birmingham, Birmingham, B15 2TT, UK, Tel.: +44 (0) 121 414 5141, Email: a.c.royal@bham.ac.uk

Author 5

- **Given name:** David N. **Family name:** Chapman, Professor of Geotechnical Engineering, BSc (Hons), DIS, PhD, CEng, MICE, FHEA
- School of Engineering, Department of Civil Engineering, College of Engineering and Physical Sciences, University of Birmingham, Birmingham, B15 2TT, UK, Tel.: +44 (0) 121 414 5150, Email: d.n.chapman@bham.ac.uk

Author 6

- **Given name:** Philip R **Family name:** Atkins, Senior Lecturer, CEng, BSc, MPhil, FIOA, AFRIN, MIET
- School of Engineering, Department of Electronic, Electrical and Computer Engineering, College of Engineering and Physical Sciences, University of Birmingham, Birmingham, B15 2TT, UK, Tel.: +44 (0) 121 414 4329, Email: p.r.atkins@bham.ac.uk

Author 7

- **Given name:** Christopher D.F. **Family name:** Rogers, Professor of Geotechnical Engineering, Eur Ing, BSc, PhD, CEng, MICE, MIHT
- School of Engineering, Department of Civil Engineering, College of Engineering and Physical Sciences, University of Birmingham, Birmingham, B15 2TT, UK, Tel.: +44 (0) 121 414 5066, Email: c.d.f.rogers@bham.ac.uk

### **Abstract:**

The functioning of modern societies relies on the successful performance of its infrastructure. In the UK much of the buried infrastructure is located below the road surface, and routine maintenance of these requires networks to be accessed, commonly by open cut methods. The open cut operation in roads is likely to change the performance of the pavement structure, and potentially how loads are transmitted, thereby affecting the buried infrastructure. The main objective of this paper is to investigate the impact of open cut construction on the road, ground and buried infrastructure with the aim of improving the current associated guidelines.

A fully instrumented site trial was undertaken where two pipes were installed using trenching in a road, with one reinstated according to the higher end of the UK specification and the other on the lower end of the specification. The trench reinstated according to the lower end of the specification experienced serviceability failure, where large settlements (approximately 70 mm) and deflections (up to 2000 microns) were observed. The other trench also experienced distress, although to a much reduced level. This demonstrates that trenching, even when reinstated according to the higher end of the specification, still weakens the existing road locally.

### **Keywords:**

Infrastructure planning, Roads & highways, Excavation, Quality control, Service life

## List of notation

DCP	Dynamic Cone Penetrometer
FWD	Falling Weight Deflectometer
HDPE	High Density Polyethylene Plastic
OCS	Open Cut Streetworks
TDR	Time-Domain Reflectometer
PFA	Pulverized Fuel Ash
VWC	Volumetric Water Content

## 1 Introduction

Modern, developed societies are fundamentally dependent upon the successful performance of their infrastructure (i.e. roads, buried utilities and equally importantly, but often overlooked, the surrounding ground). Any disruption to their function and serviceability can lead to costly consequences (Matthews and Allouche, 2010; Matthews *et al.*, 2015). These infrastructure systems, which might be many decades old, require maintenance and possible upgrading to cope with the demands placed upon them, while various public and private organisations are tasked with overseeing them (depending on the country). In this complex system an organisation might overlook the needs of surrounding infrastructure when attempting to manage their own system. This is unfortunate as it is recognised that individual infrastructures form interconnected systems with others in local proximity; where interventions on one can have unintended, and potentially negative, implications on the relative performance of others.

For instance, deteriorated roads have been shown to accelerate the deterioration of buried utilities (Clarke *et al.*, 2017). Furthermore, the vast majority of installation, maintenance, and replacement of buried utilities are currently conducted through Open Cut Streetworks (OCS) (i.e. trenching) with significant negative impacts on the lifespan of roads (Shahin *et al.*, 1986; Alinizzi *et al.*, 2018). OCS is estimated to be responsible for around a 30% reduction in structural life of roads (Steele *et al.*, 2003). The increasing number of OCS in England and Wales, around 2.5 million in 2015-16 (a 13% increase compared to 2014), cost the local

authorities, on average, 13% of their maintenance budget in relation to repetitive road maintenance (Asphalt Industry Alliance, 2016). Previous research indicates that OCS significantly increases water ingress into the pavement structure (normally through the joints between the trench and the existing road structure) and this can lead to significant surface deformations over time (Schaefer *et al.*, 2005; Stevens *et al.*, 2010; McHale, 2013).

Water entering into the road structure potentially permeates into the ground beneath and interacts with the foundation soil, unless there is sufficient drainage in place (Stevens *et al.*, 2010). This can result in softening of the soil, which not only changes the bearing capacity of the ground, potentially impacting upon the performance of the pavement above, but also changing the loading conditions on the buried infrastructure (Gould *et al.*, 2009; Rajeev and Kodikara, 2011; Clair and Sinha, 2014). Inappropriate reinstatement processes can also result in weakened ground conditions that impact on both the surface and buried infrastructure. In both situations the changes in ground condition are often overlooked (the ground is often considered inert, but this is often not the case), yet its response is fundamental to the performance of those infrastructures sitting on or buried within it. The authors therefore suggest that the ground should be deemed an equally important infrastructure and the linchpin that interconnects the surface and buried infrastructure.

In an attempt to investigate the impact of OCS construction, including excavation and reinstatement, on the interconnectivity of the surface, ground and buried infrastructures, a field trial was undertaken on a 'controlled', yet real, site. The impacts of three components of the OCS construction were investigated, namely, the backfill material and its compaction, and the joint seals. These parameters were selected to showcase the impact of inappropriate OCS practice, which may happen in reality, and to show the need for enforcing the use of quality control measures. The aim of the research was to provide important independent evidential data for practitioners and policy makers to help improve the current guidelines on OCS practice and buried infrastructure management, by emphasising the need to adopt robust quality control measures. The paper initially presents a review of previous research into OCS practice, followed by a detailed description of the trial site construction and instrumentation. Key results from the research are then presented and discussed.

## 2 A Summary of Previous Research into the Impacts of OCS

The negative impacts of trenching on road service life and its functionality have been reported in many previous studies (e.g. Carder and Taylor, 1983; Fleming and Cooper, 1995; Burtwell and Spong, 1999; Chow and Troyan, 1999; Lee and Lauter, 1999; Nichols-Vallerga & Associates, 2000; Steele *et al.*, 2003; Jensen *et al.*, 2005; Schaefer *et al.*, 2005; Stevens *et al.*, 2010; McHale, 2013). For instance, Fleming and Cooper (1995) conducted an extensive trenching monitoring programme, collecting settlement data from over 100 trenches over a three year period. The measured data showed that approximately 36% of the monitored trenches were settling one year after the reinstatements, at an average rate of 1 mm per month. Schaefer *et al.* (2005) identified two main processes responsible for settlement, namely:

1. Poor compaction of the backfill materials, caused, for example, by:
  - a. low energy input (e.g. limited number of passes),
  - b. inappropriate selection of layer thickness prior to compaction,
  - c. use of material with a water content significantly different from the optimum (for example if the material has been left exposed to wet or freezing conditions);
2. The use of inappropriate backfill materials.

Backfill materials (e.g. granular, manufactured, and recycled) and compaction procedure (e.g. applied energy), and their correlation with road deterioration have also been examined in the past and found to be of critical importance (e.g. Macy, 2002; Schaefer *et al.*, 2005; Stevens *et al.*, 2010).

Settlement can lead to preferential pathways for surface water, inducing water accumulation and increased infiltration, potentially accelerating the deterioration of the road. However, ground movements are not limited to the vertical plane nor the boundaries of the trench and this can be overlooked when considering the suitability of a reinstatement. For example, previous research indicates that disturbance to the road structure adjacent to the excavated area occurs (Lee and Lauter, 1999; Steele *et al.*, 2003; Jensen *et al.*, 2005). This weakened zone, sometimes termed the ‘the zone of influence’, has been reported to extend around 0.5 m to 1.0 m beyond the trench boundary, and is caused by stress relaxation leading to lateral soil

movement during construction, which cannot be restored to the required specifications during reinstatement (Stevens *et al.*, 2010).

The negative impacts of varying water content in the backfill material during and after construction have also been studied. For example, the collapse potential of granular backfills under a low degree of saturation have been investigated in a number of studies (Jensen *et al.*, 2005; Schaefer *et al.*, 2005; Stevens *et al.*, 2010). The findings showed that the highest collapse potential for the tested granular material was achieved when the water content was in the range of 4% to 8%. Whilst this range would not necessarily apply to all soils, the water contents were lower than the optimum values for the soils. Hence, the negative pore water pressures developed during compaction improved the stiffness and strength of the backfill, but with seepage of water into the backfill these negative pore water pressures (partially) dissipated, resulting in a reduction in strength and stiffness and self-weight compression. These backfills were fundamentally metastable in nature. Water content values closer to the optimum increase the achievable density and decrease the potential for collapse. This demonstrates the importance of controlling water content during the road construction and trench reinstatement. It also demonstrates that measuring stiffness or strength alone would not necessarily provide a guarantee of conformity, as these measurements alone do not provide an indication of the potential meta-stability of the backfill.

## 2.1 Problem statement

The current UK specification for Street Works (Department of Transport, 1991) has the potential for wide interpretation when it comes to trenching and reinstatement operations. There is also only a requirement for those conducting these operations to be responsible for a period of two years after the OCS, i.e. to provide a two-year guarantee. As a result, the current practice for conducting Street Works could tend towards the lower end of the specification rather than the higher end.

Despite previous studies investigating the negative impacts of trenching and also the individual factors related to trenching practice and road conditions, none of these studies have provided a direct experimental comparison between OCS practices on higher and lower ends of the specification, where both the practices comply to the current specification (i.e. in the UK Department of Transport, 1991).

The research hypothesis is that even when the UK specification for Street Works involving OCS are followed, those reinstatements at the lower end of the specification can have a much

greater negative impact on road condition when compared to those reinstatements conducted at the higher end of the specification. This information would be extremely valuable to both practitioners and regulators, and would provide evidence that could be used to improve the current guidelines and field practices related to trench construction and reinstatement. Hence, this is the focus of this paper.

Furthermore, the correlation between rainfall and water ingress through unsealed reinstatement joints has not been studied previously, a shortfall which is also addressed in this paper.

### **3 Methodology**

A test site was developed at the University of Birmingham (UK) campus and comprised an existing road, with restricted access, being used during the study period by lorries and other heavy vehicles involved with the demolition of a nearby building. Due to the location of the site, only limited access was granted to the research team.

The OCS undertaken on the test site involved the excavation of two trenches, the installation of an instrumented (air filled) plastic pipe in the base of each trench, and backfilling (including pipe bedding, capping layer and road subbase) before the road was resealed. One trench, Trench 1, was reinstated according to the lower end of the specification and Trench 2 was constructed following the higher end of the specification [both following the reinstatement guidelines stated in Department of Transport (1991)]:

- Trench 1 used sub-optimal materials, reduced layer thickness and poor compaction.
- Trench 2 followed best current practice with high quality materials, a thicker surface layer and good compaction.

Table 1 provides further details of the two reinstated trenches.

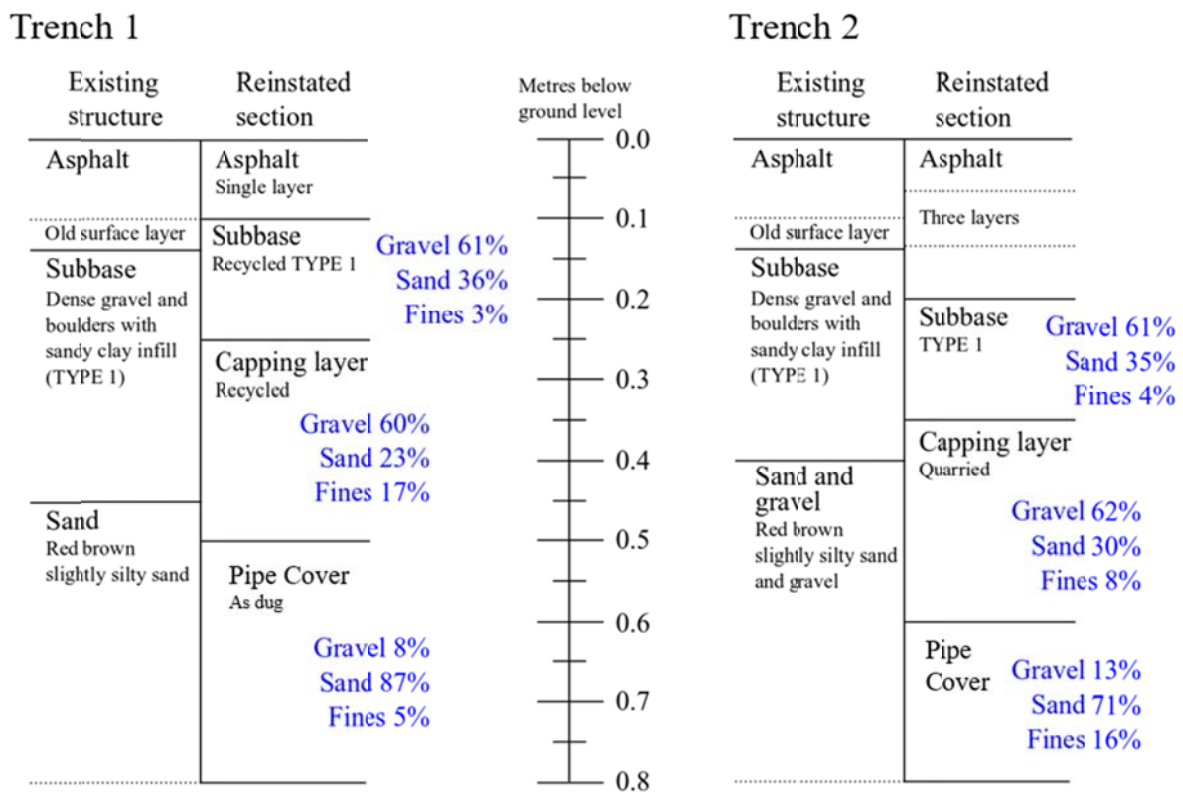


**Table 1: Characteristics of the two trenches constructed for the field trial**

Trench 1		Trench 2	
Material	Thickness (mm)	Material	Thickness (mm)
Sand (as dug)	300	Sand	200
Recycled Capping (granular)	250	Quarried Capping Layer	250
Recycled Type 1*	150	Type 1*	150
Hot rolled Asphalt	100 (1 layer)	Hot rolled Asphalt	200 (3 layers)
Compaction after recycled Type 1		Compaction on all layers	

\*As defined by Department for Transport (2012)

Figure 1 shows the layout and the measured particle size distribution of the existing and reinstated ground layers.



**Figure 1: Layout of the existing and reinstated road structure (including the particle size distribution of the reinstatement materials)**

Figure 2 shows the reinstated trenches, excavated in a V-shape in plan so that a single control station could be used and to minimise the length of cabling. The dimensions of each trench were: 8 m long, 0.9 m wide and 0.8 m deep. High-density polyethylene plastic (HDPE) pipes,

100 mm diameter, equipped with acoustic sensors were located in each of the trenches so that the condition of the pipe could be checked for the duration of the trial. Unfortunately, these sensors were damaged during construction and therefore were not used.

The joints between the Trench 1 constructed trench and the existing road were not sealed (Figure 2b), while these joints for the Trench 2 were sealed using over-banding tapes and painting the trench walls with bitumen. Additional poor joints were created on the Trench 1 constructed trench by laying a middle section with vertical edges, rather than the recommended stepped overlapping joints, again without using any over-banding tape.



**Figure 2: (a) The two reinstated trenches and (b) construction of the poor joints**

The rationale was to monitor surface movements, subsurface changes and changes in pipe properties (i.e. acoustic) in an effort to tie these trends to both the traffic loads and the weather conditions. The data collection period lasted approximately 10 months, commencing in February 2017.

Unfortunately, the sensors within the two buried pipes ceased communicating with the data collection facilities early on and attempts to re-establish communication at the sensor hub (a waterproofed shed) were to no avail.

Historical data on the road construction were unavailable, although it is believed to have been originally constructed approximately 50 years ago. However, data on the road structure as well as the subgrade was gathered during the trenching operations.

### 3.1 Sensing techniques

Sensors were installed in the subbase and subgrade layers under the asphalt and a weather station was installed next to the excavated area to monitor the ambient conditions throughout the trial period (see Figure 3, Figure 4 and Table 2 for more details on the sensors).

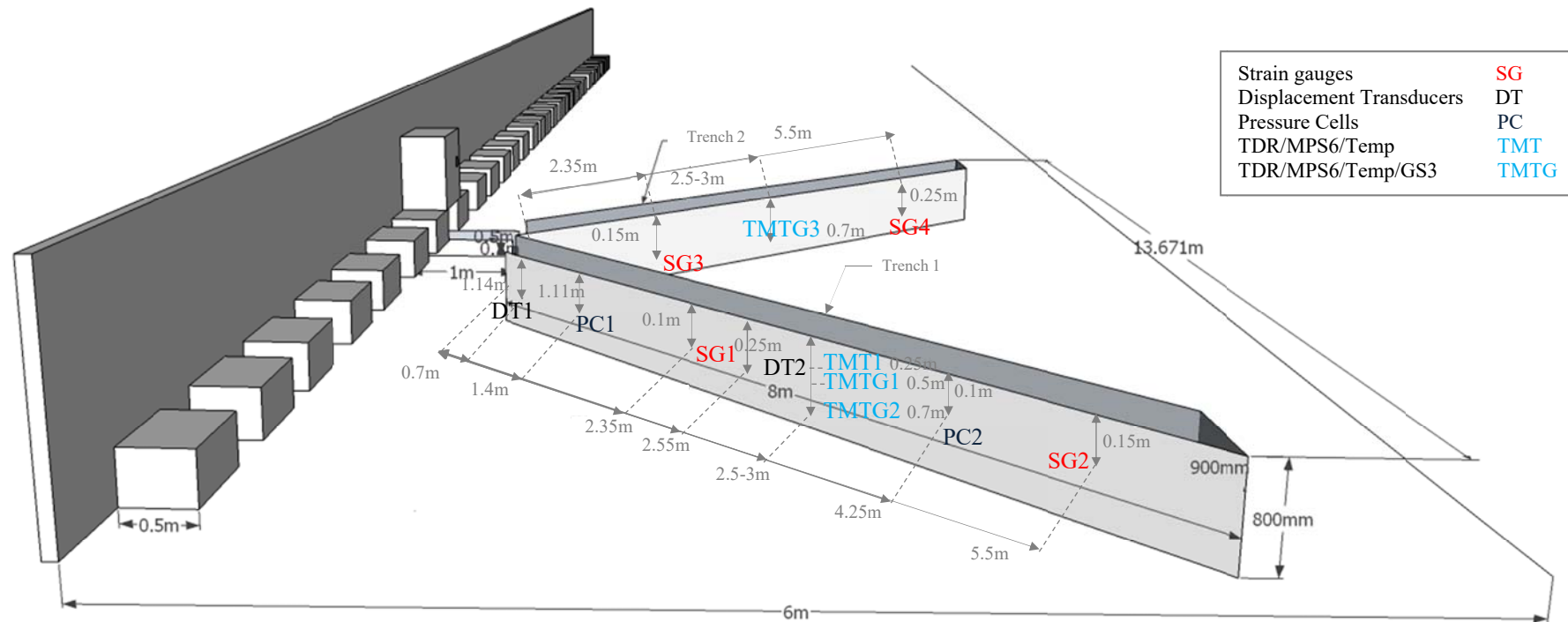


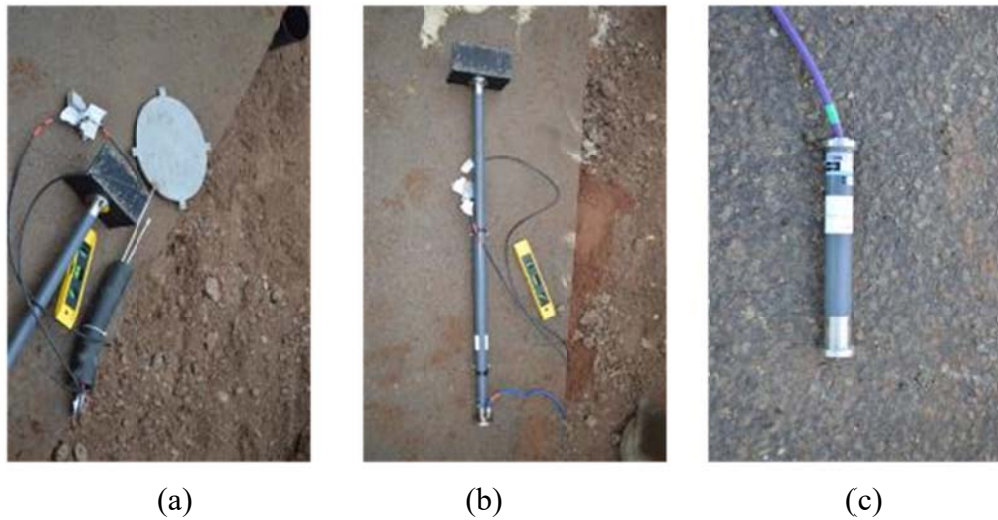
Figure 3: Location of the installed sensors

**Table 2: List of sensors used in the field trial and their main characteristics**

Sensor	Trench/No. of sensors	Measured parameter	Measurement interval	Supplier/Model
Displacement Transducers	Trench 1/No. 2	Lateral soil displacement from the trench walls	2 hours	Geokon™ Inc/ 4435-2-300 mm
Pressure Cells	Trench 1/No. 2	Lateral pressure on the trench walls	2 hours	Geokon™ Inc/ Model 4800-1
Strain gauges	Both trenches/No. 4 (2 for each trench)	Vertical strain (microstrain)	0.5 seconds	Geokon™ Inc/Model 3900
Soil water content sensors (Time Domain Reflectometer, TDR)	Both trenches/No. 6 (3 for each trench)	Soil water content	4 hours	Campbell Scientific/Model CS635 with SDMX50 multiplexers and TDR100 unit
Soil water content sensors	Both trenches/No. 4 (2 for each trench)	Soil water content	4 hours	Metergroup (previously Decagon Devices)/Model GS3
Temperature sensors	Both trenches/No. 6 (3 for each trench)	Temperature	4 hours	Campbell Scientific/Model 107
Weather sensors	N/A	Ambient weather parameters	1 hour (summary of higher sampling frequency)	Metergroup/Model Atmos-41
Traffic counter sensors	Trench 1	Traffic passes, vehicle type	Recorded continuously	MetroCount

Additional sensors were installed in Trench 1. For example, displacement transducers and pressure cells were only installed in Trench 1 to monitor the potential inward soil lateral movement and lateral pressure during construction of the nearby Trench 2. Soil water content sensors (i.e. GS3 sensors, see Table 2) were also installed in Trench 1 to complement the time-domain reflectometer (TDR) soil water content sensors. TDR and temperature sensors were installed in both trenches at different depths to measure the water content and temperature gradients with depth in the subbase and subgrade layers, respectively. Strain

gauges were also installed vertically just beneath the asphalt layer to measure microstrain caused by passing vehicles. In addition, the traffic was monitored (at least partially, see Section 4) using a traffic counter system (MetroCount<sup>®</sup>), and a CCTV camera that was capable of motion detection (the camera was also installed for security purposes).



**Figure 4: Sensors utilised in the trial: (a) Pressure cell, (b) Displacement transducer and (c) Strain gauge**

In addition to the permanently installed sensors described above, a number of surveys were conducted to assess the functional condition of the road and complement the *in situ* tests (Table 3).

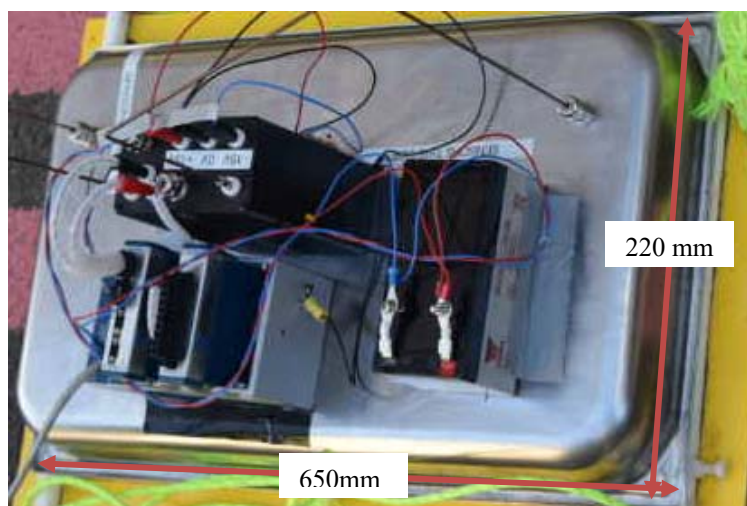
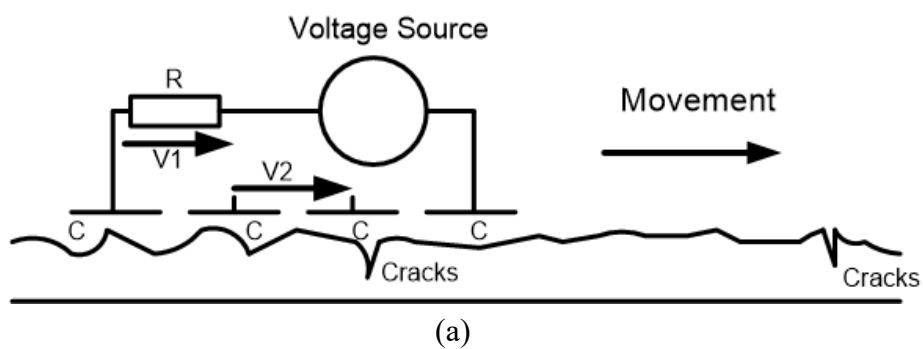
**Table 3: The utilised test/monitoring techniques**

Test/monitoring technique	Supplier
Falling weight deflectometer (FWD)	Dynatest <sup>®</sup> (2018);
PANDA a dynamic cone penetrometer (DCP) as an <i>in situ</i> method	Corehard Ltd (2013)
In-house levelling surveys with a semi-automatic total station (Leica, model TS15)	University of Birmingham
In-house developed non-contact electrical resistivity	University of Birmingham

All the methods listed in Table 3 are commercially available except for the non-contact electrical resistivity, which was developed in-house and is not conventionally used for road assessment, therefore some details of this technique are provided below.

Asphalt is a very high resistive material, but the presence of water in asphalt can result in lower resistivity. A degraded and/or poorly compacted asphalt has more voids and hence can retain more water. Using the resistivity technique it is possible to examine the quality of the asphalt and the presence of any cracks or voids in the asphalt. However, the conventional resistivity techniques are mainly invasive and time consuming as they require electrodes to be inserted into the ground (Metje *et al.*, 2007; Reynolds, 2011).

The non-contact resistivity sensor utilised in this study used a similar setup to the Wenner array by injecting a known current into the ground and measuring the induced voltage at a known distance. The current was induced in the ground using rectangular capacitive plates. The current source was replaced with a voltage source, and the voltage drop across a precision known resistor was used to measure the injected current. This setup is depicted in Figure 5.



(b)

**Figure 5: Non-contact resistivity sensor (a) Schematic of the measurement unit and (b) the actual unit, the active sensing area is 640 mm × 110 mm**

The measurement unit was mounted on a robotic unit (a moving cart) and was controlled automatically with a Leica Total Station to survey the area on a 10 cm by 10 cm grid typically sensing features within 10 cm of the electrodes. The raw data was conditioned and smoothed using a spatial low-pass filter with a circular impulse response of diameter 25 cm.

## **4 Results**

### **4.1 Water ingress monitoring**

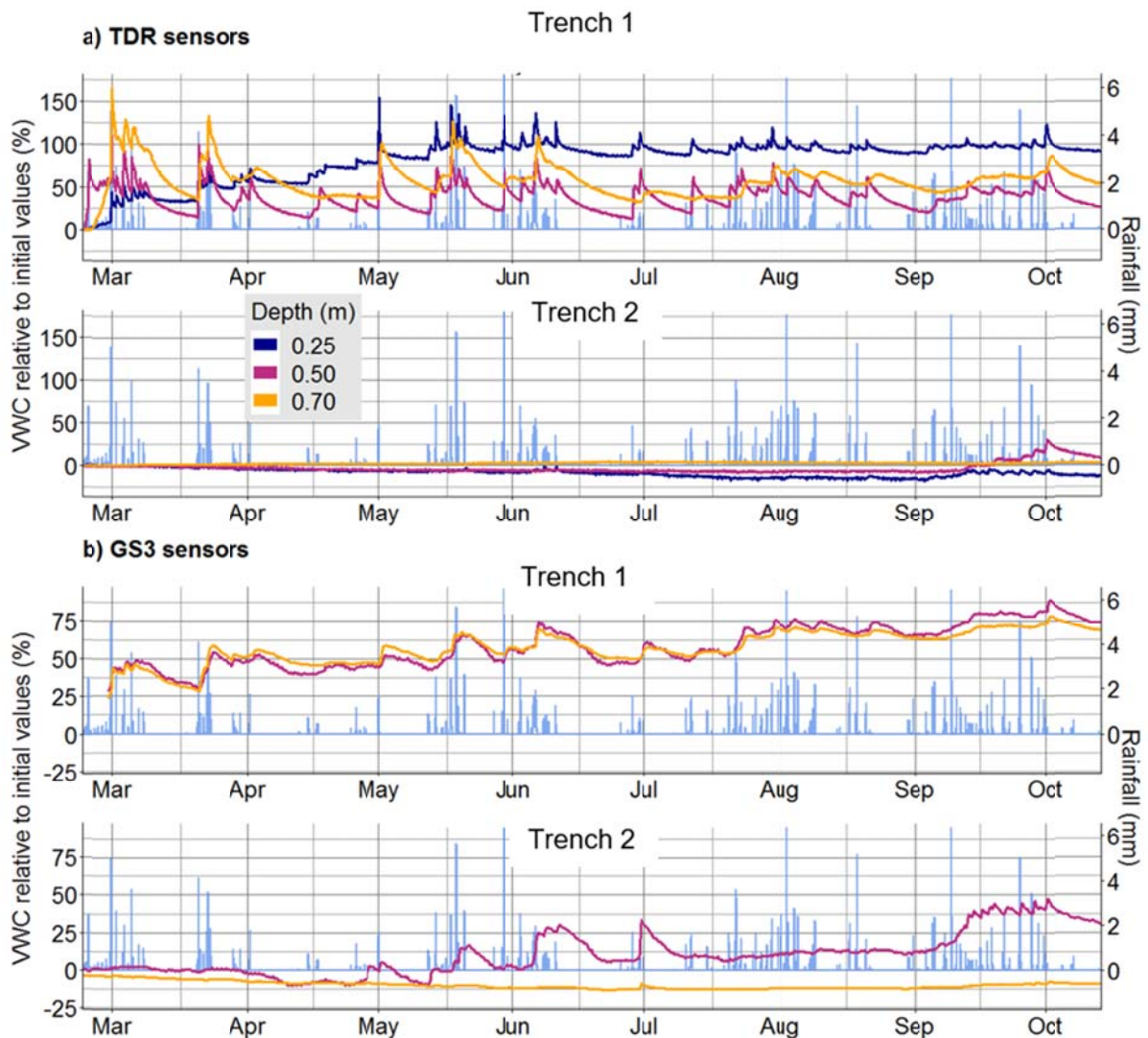
The main environmental factors linked to road deterioration in the UK are the amount of rainfall leading to water infiltration, freeze/thaw processes and general temperature variations potentially contributing to the physical deterioration of the road structure (note that chemical processes were not considered in this study) (Dunn and Hudec, 1972; Cawsey and Massey, 1988). Poor road joints, as well as cracks and defects, can provide routes for water ingress into the road structure. As water content was monitored at different layers throughout the trial, it was possible to say which one of these was responsible for water ingress (i.e. cracks were developed towards the end of the trial).

During the monitoring period, no snow precipitation occurred, but a number of rainfall events were recorded with a maximum daily precipitation of between 6 and 7 mm on three occasions (Figure 6). The volumetric water content (VWC) measured by the TDR and GS3 sensors are shown in Figure 6a and b, respectively, at different depths relative to the initial values measured soon after installation. Clearly these results show a significant difference in the infiltration rates, with smaller water content variations in Trench 2 (typically well below 50 % relative change) and significant changes corresponding to rainfall events in Trench 1 (sometimes of over 100 % relative change and regularly affected by rainfall events). The difference in water content between the two trenches, which can be seen from the start of the trial, is an indicator of the significant negative impact of unsealed joints.

The use of relative values was preferred as this provides a better indication of the variation. However, the measured VWC by the two sensor types did not always match due to the different operating principles and the heterogeneous nature of the soil. With respect to the relative measurements presented, it is interesting to note that the TDR measured sharper spikes corresponding to rainfall events in Trench 1 and approximately constant values in



Trench 2 except in October when some water reached the probe at 0.50 m depth (Figure 6a). The GS3 sensors buried at 0.50 m depth in Trench 2 measured clear variations in VWC throughout the monitoring period, although the magnitude of the changes was typically smaller than the changes recorded in Trench 1 (Figure 6b). It is possible that water reached the location of this sensor through a preferential water path (possibly laterally). An alternative hypothesis is that the road above the sensor started to degrade due to traffic loading and associated cracks and small defects were responsible for that water change (some surface damage was indeed observed visually during site inspections in May). As discussed later, vehicles started moving regularly across the site from the 18<sup>th</sup> of April and the larger variations measured by this sensor were subsequent to this date (Figure 6b).



**Figure 6: Volumetric water content (VWC) change relative to the initial values measured soon after trench reinstatement obtained from (a) TDR sensors and (b) GS3 sensors installed at different depths. (Note the black vertical lines indicate the rainfall events)**

Figure 7 shows the air temperature and the temperature measured at different depths in Trench 1 (the results from the other trench were very similar and hence are not shown). Sub-zero temperatures were not measured and the maximum temperatures of approximately 30 °C were rarely reached and only then for a limited time, suggesting that temperature did not play a major role in deteriorating the road during the trial period. The seasonal and diurnal variation encountered on site and the gradient with depth can also be observed in Figure 7. The temperature was consistent in both trenches with only small variations measured (typically well below 1 °C) between the two trenches. These differences were slightly more

pronounced at a shallow depth of 0.25 m with Trench 1 exhibiting slightly higher temperature than Trench 2, probably due to the higher air content and interconnected voids caused by small cracks and poor joints. However, the differences were small and uniform throughout the monitoring period and could also be caused by the different position of the sensors (for example if the sensors were installed at slightly different depths) or by slightly different systematic errors. These results suggest that the heat transfer was not significantly affected by the construction method of the trenched sections, which is an interesting finding in itself.

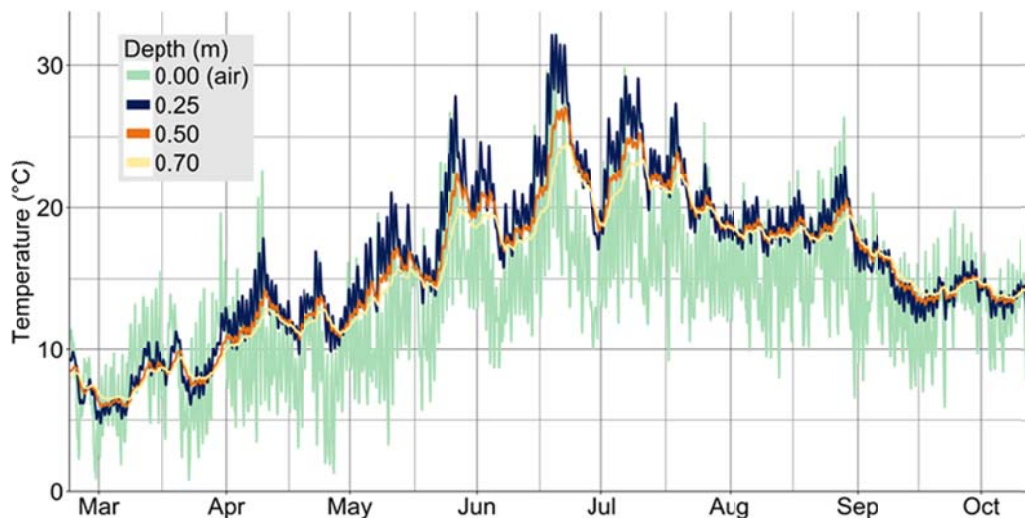


Figure 7: Air and soil temperature variation at different depths during the trial period.

## 4.2 Backfill material and compaction

Road deterioration can be caused by various triggers, including excessive water and inappropriate backfill material and compaction, although these are not always mutually exclusive. As such, it is not always possible to differentiate road defects based on their exact trigger. However, the following sections report the results of observations and measurements, and where possible the potential trigger and interactions have been highlighted. Water ingress in this study was measured independently, and therefore was reported separately.

### 4.2.1 Response to traffic loading

In addition to the environmental factors described previously, the other major driver of road deterioration is cyclic loading from traffic, particularly from multi-axle heavy vehicles such as lorries (Krechowiecki-Shaw *et al.*, 2016). Traffic counters were used to monitor the number and type of vehicles passing over the two trenches.

Figure 8 shows the daily vehicle counts measured by the traffic counters and classified according to the number of axles. The majority of vehicles during this period had two axles and generally the number of counts of vehicles with greater than 2 axles followed the same pattern as the 2 axle vehicles. Higher traffic numbers were recorded from the middle of June onwards. The strain gauge sensors buried just beneath the asphalt layer measured increasing microstrain over time (Figure 8b and c). The largest measured increase corresponded to the increase in traffic in the second half of June. Increasing microstrain is caused by movement of the road structure, which was significantly higher in Trench 1, up to 50% (Figure 8b and c), as a result of inadequate compaction. A small settlement is expected when a new road section is subjected to traffic loading, due to further compaction (Frost, 2000). One of the sensors in Trench 1 (SG1 in Figure 8b) measured significantly higher microstrain compared to both the sensors in Trench 2, which measured very consistent values, although they still reached 6000 microstrain (i.e. up to 2/3 of Trench 1 values, Figure 8c). The second sensor in Trench 1 (SG2 in Figure 8b), did not measure equivalent long-term trends. This is thought to be caused by the significant settlement (of the order of centimetres, see Section 4.2.2 for more details) occurring near to this sensor. The strain gauges were installed vertically and they measured microstrain based on the ratio between the displacement of the moving part of the sensor over its length. It is believed that the whole SG2 sensor (Figure 8b) was pushed downwards and therefore a long-term increase in microstrain was not measured. The regular spikes measured by all the strain gauges were related to the passage of vehicles confirming the cyclic behaviour of microstrain under regular traffic loading.

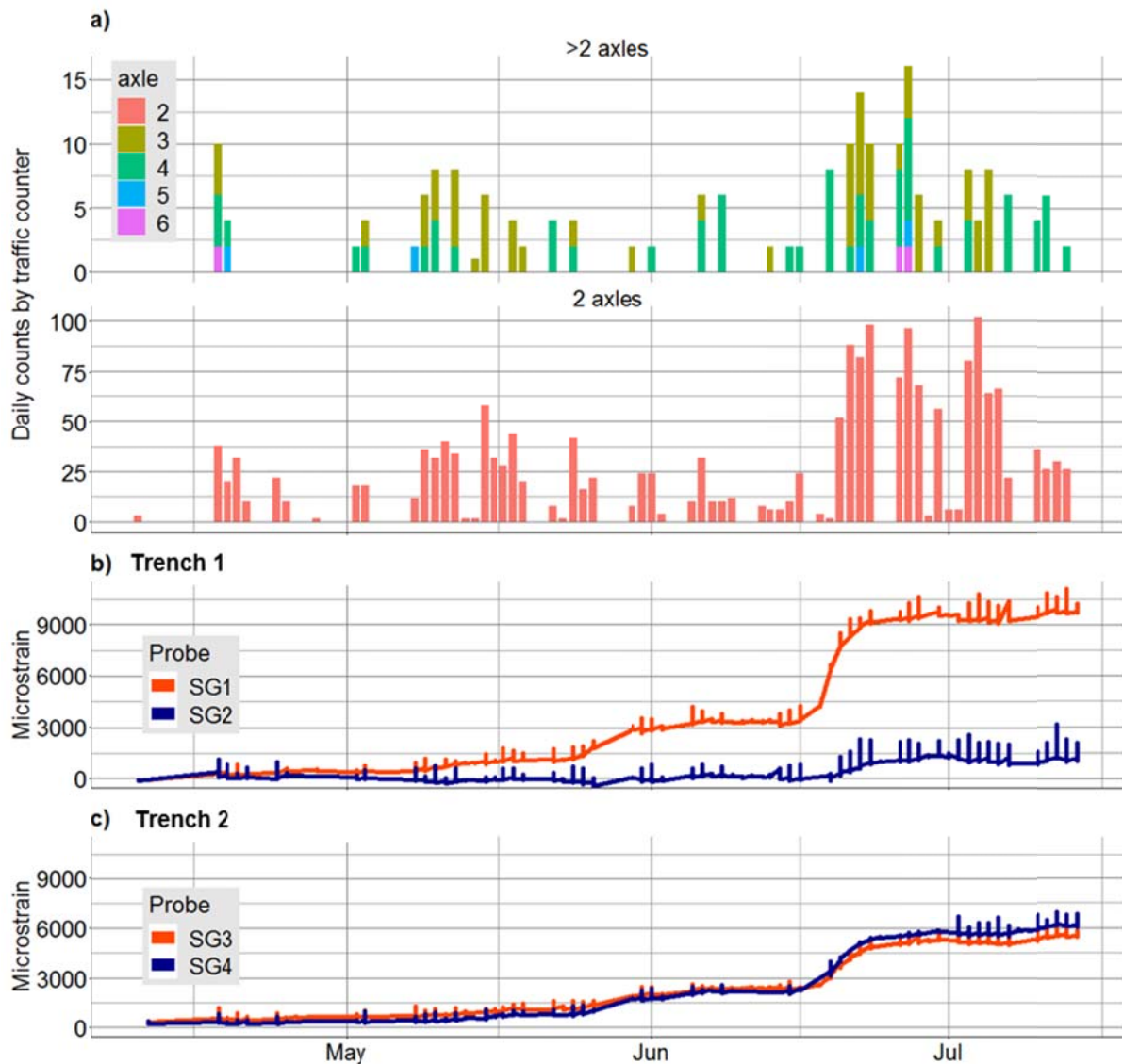


Figure 8: (a) Volume of traffic measured by traffic counters, (b) and (c), microstrain measured by strain gauges located immediately beneath the asphalt layer in Trench 1 and Trench 2, respectively.

#### 4.2.2 Road condition assessment

In order to complement the *in situ* sensors, the condition of the reinstated trenches was also assessed with a number of techniques, most of which can be used as quality control measures for OCS operations as described below. Figure 9 shows the results of the PANDA DCP surveys conducted at the beginning (immediately after trench reinstatement) and at the end of the experiment (10 months later). For each visit, two measurements of the cone resistance were taken in each trench and the results averaged and smoothed to facilitate interpretation. Only the depth up to 0.8 m corresponding to the road structure was investigated. The results provide a clear indication of the impact of the trench reinstatement methods on the quality of

the material in the two trenches, with significantly lower resistance exhibited by Trench 1 compared to Trench 2 immediately after reinstatement (Figure 9).

The PANDA DCP can be used to estimate the elastic modulus ( $E$ ) of granular material (Lamas-Lopez *et al.*, 2016) using Equation 1 developed by Chua (1988).

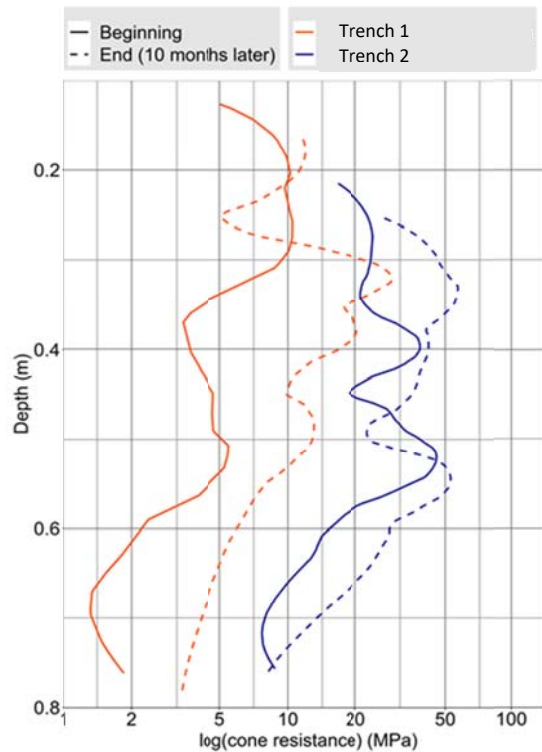
**Eqn. 1**

$$E = 23.2 \times \log(\text{Cone Resistance}) + 12.5$$

The Highways Agency (2006) requires a minimum 50 MPa elastic modulus for Foundation Class 1 (capping layer only design for less than 20 million standard axles) and 100 MPa for Foundation Class 2 (capping and/or subbase layer design, for less than 80 million standard axles). Using Equation 1 these limits correspond to 1.6 MPa and 3.8 MPa, expressed as  $\log(\text{Cone Resistance})$ .

After a period of 10 months and as a result of the heavy traffic loading, the cone resistance consistently increased in both trenches with only a couple of exceptions. Although the tests were conducted within 1 m from the location of the first survey, the decrease at certain depths is likely to be due to local conditions of the trench material. The mean increase in cone resistance was 5.9 MPa and 10.8 MPa for Trench 1 and Trench 2, respectively, with a maximum increase of 18.4 MPa and 35 MPa, respectively (note that Figure 9 shows the cone resistance on a logarithmic scale, while these values are absolute). This indicates that although both trenches became stiffer over time Trench 2 became relatively stiffer and its resistance remained significantly larger compared to Trench 1. This implies that the section of road associated with Trench 1 would exhibit reduced performance over time.

This method can be used after backfilling and prior to resurfacing to assess the quality of backfill material and compaction by estimating the elastic modulus and comparing it with the design code as described above. As for an entire road network, collecting data on a regular basis can help the asset owner make a more informed judgment on the likely performance of trench reinstatements based on historical data that go beyond the broad specifications made in the guidance notes. For example, it would be possible to present evidence that based on the historical data the lower limit of the specification for trench reinstatements creates unexpected risk to the road performance (as demonstrated in the trial results presented in this paper).



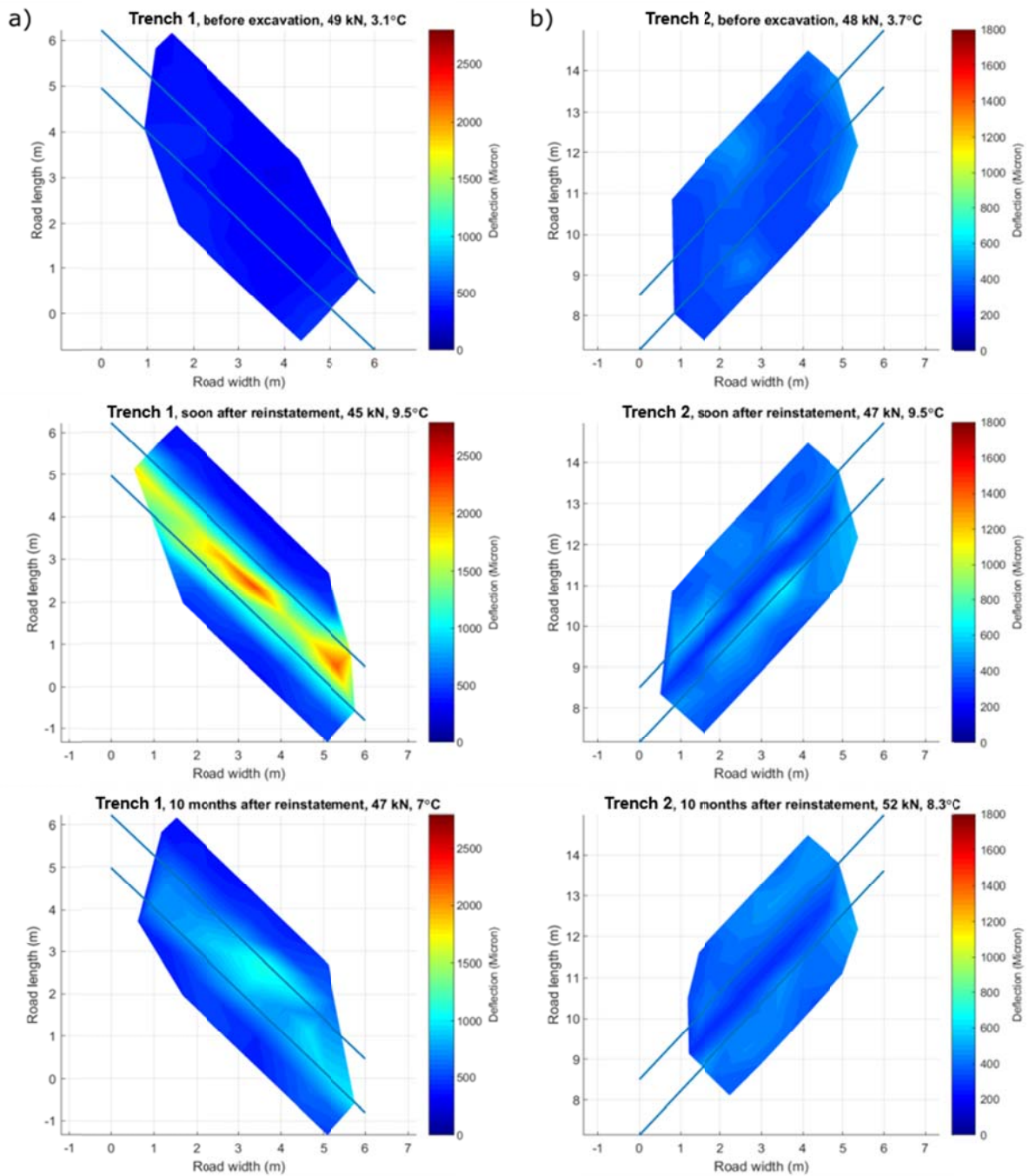
**Figure 9: Cone resistance measured in both trenches by the PANDA DCP test immediately after reinstatement (beginning of trial period) and at the end of the experiment (after 10 months).**

FWD tests were conducted at three times during the study (Figure 10). The first test was conducted on the original road before the trench excavations took place. The second test was completed a few days after reinstatement and before traffic occurred on site. The FWD test was also repeated at the end of the project, 10 months after reinstatement. Figure 10 compares the surface deflection measured for both trenches after applying a similar amount of energy (approximately 50 kN). The data were interpolated using a triangulation based linear interpolation method (Watson, 1994). The results clearly show the impact of the construction and reinstatement methods. Trench 1 exhibited significantly higher deflection after the first FWD test indicating suboptimal characteristics (Figure 10a top and middle plots). Therefore, this section of road is expected to have reduced performance. The deflection was smaller during the third visit (bottom plot in Figure 10a) suggesting increased stiffness over time. This is expected as the road settled and compacted over time, particularly after the passage of heavy traffic. However, the values remained at around 1000 micron. In contrast, Trench 2 (Figure 10b) exhibited smaller variations in deflection over time. Interestingly, it is possible to see an area of increased deflection adjacent the excavated section after the first FWD test (middle plots of Figure 10a and b). Although these results are an interpolation derived from discrete point measurements across the site they suggest that

this zone of influence potentially extends approximately 0.5 m from the edge of the excavated section. This is in line with the findings from other studies (Steele *et al.*, 2003; Jensen *et al.*, 2005; Stevens *et al.*, 2010). These results are important because they confirm that even the trenches constructed according to the current best practice and specification have an impact on the existing adjacent road structure. The deflection on Trench 2 reduced over time after traffic loading (bottom plot in Figure 10b). It should be noted that the colour scale in Figure 10a and b is different for the two trenches (Figure 10b is around 700 micron, or 40%, less than Figure 10a) to allow the corresponding changes be clearly visible and that the values for Trench 1 remained significantly higher over the entire period.

The FWD is a well-established method for road condition assessment and monitoring in the UK and elsewhere in the world. However, it is not currently used as a quality control measure for OCS. The results of this trial have shown the potential of the FWD for this purpose.

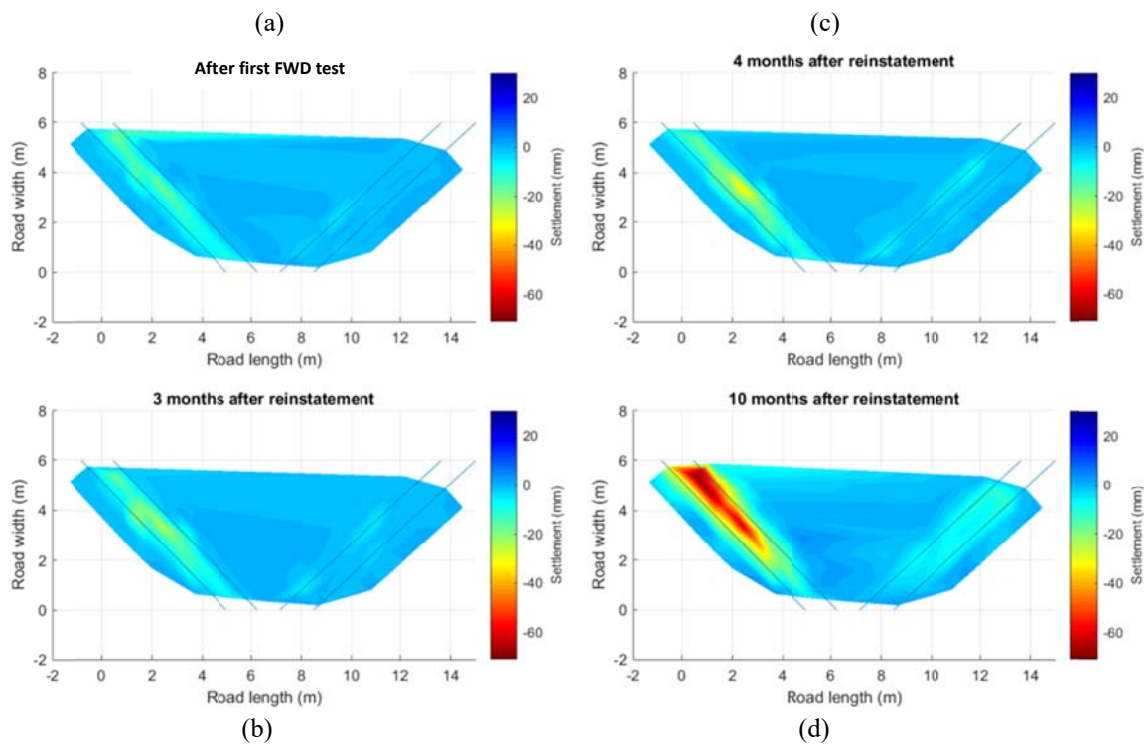




**Figure 10: Deflection measured at different times for (a) Trench 1 and (b) for Trench 2 using a FWD test with similar energy input.**

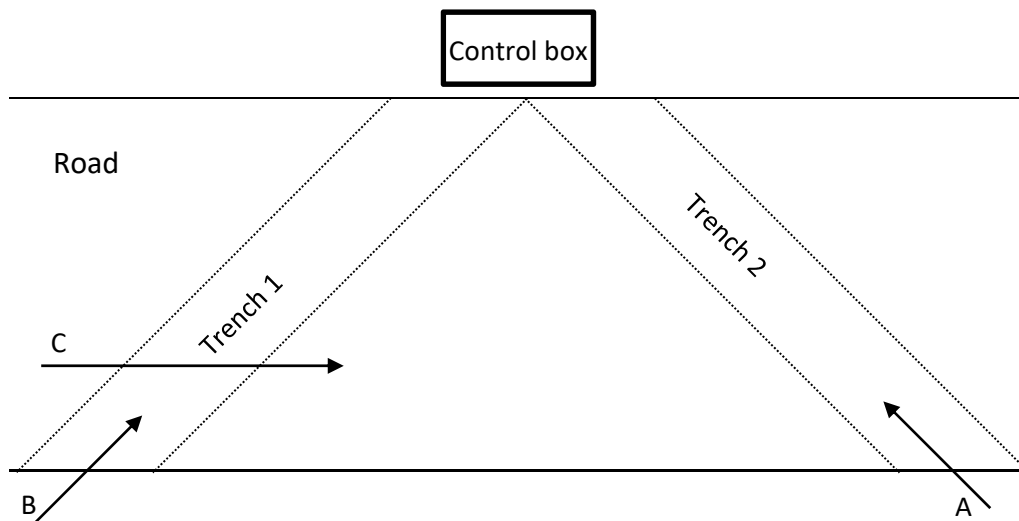
Over a period of 10 months significant settlement occurred over Trench 1, with peaks of 70 mm towards one end of the trench (Figure 11). Smaller settlement was observed over Trench 2 with values remaining typically below 10 mm over 10 months. Although quantification of the traffic loading for the whole period was not possible due to the failure of the traffic counters, it is known from the CCTV images, strain gauge data and site visits that regular heavy loading occurred on site for a period of two months between late August and

early October 2017. As mentioned above, tracked vehicles were often used on site and so were heavy lorries loaded with demolition waste. Although the trial only lasted a few months, the loading intensity was substantial and hence the results (e.g. settlement) can be used to show long-term effects. These results provide additional confirmation of the significantly reduced performance of Trench 1 section of road compared to Trench 2 section. The majority of the settlement (up to approximately 20 mm) occurred immediately following the second FWD test (the first test after reinstatement, Figure 11a), when significant load was applied at specific point locations across the investigated area. Total station measurements taken three and four months after reinstatement (Figure 11b and c) demonstrate that settlement increased quickly following initial traffic loading, starting on 18 April (around two months after reinstatement), although the vast majority of vehicles recorded during this period had less than 4 axles indicating relatively low levels of loading (Figure 8).



**Figure 11: Change in settlement relative to the measurement immediately after the reinstatement: (a) after first FWD test, (b) three months, (c) four months and, (d) ten months after reinstatement**

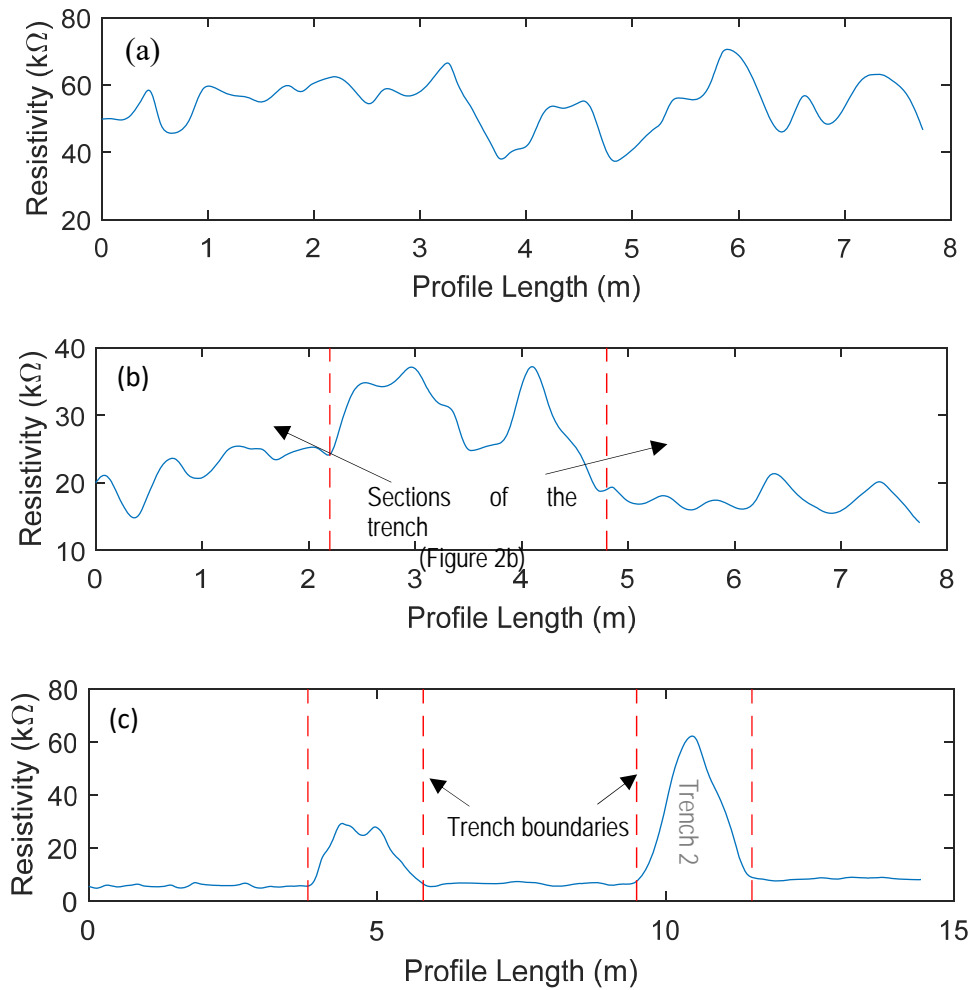
The condition of the road and trenches were also assessed soon after the reinstatement using the in-house non-contact electrical resistivity (see Section 3.1). The results are presented as resistivity profiles calculated in the direction of the arrows shown in Figure 12.



**Figure 12: Schematic of the measured area in plan; the arrows show the direction of each of the non-contact electrical resistivity measurement (corresponding to the results presented in Figure 13)**

The survey was conducted during winter corresponding to a wet and rainy period. Although during the actual measurements the surface was reasonably dry, it had been exposed to considerable rainfall beforehand. Figure 13 shows that the existing asphalt had relatively low resistivity compared to the newly reinstated trenches due to the higher water content caused by the deterioration of the asphalt layer over time. The measured profile for Trench 2 showed a very high resistivity, which indicates dry conditions in the surface layer. However, Trench 1 showed a lower value of resistance indicating a higher water content.

The three sections of Trench 1 are also visible in Figure 13 with the middle section having slightly higher resistivity than the adjacent sections of the same trench. This difference may be caused by the middle section containing less water than the other two sections as it was laid later than the others and had been exposed to less rainfall by the time the measurements were taken.



**Figure 13: Measured resistivity (directions are shown in Figure 12) along: (a) Trench 2; (b) Trench 1; (c) the road.**

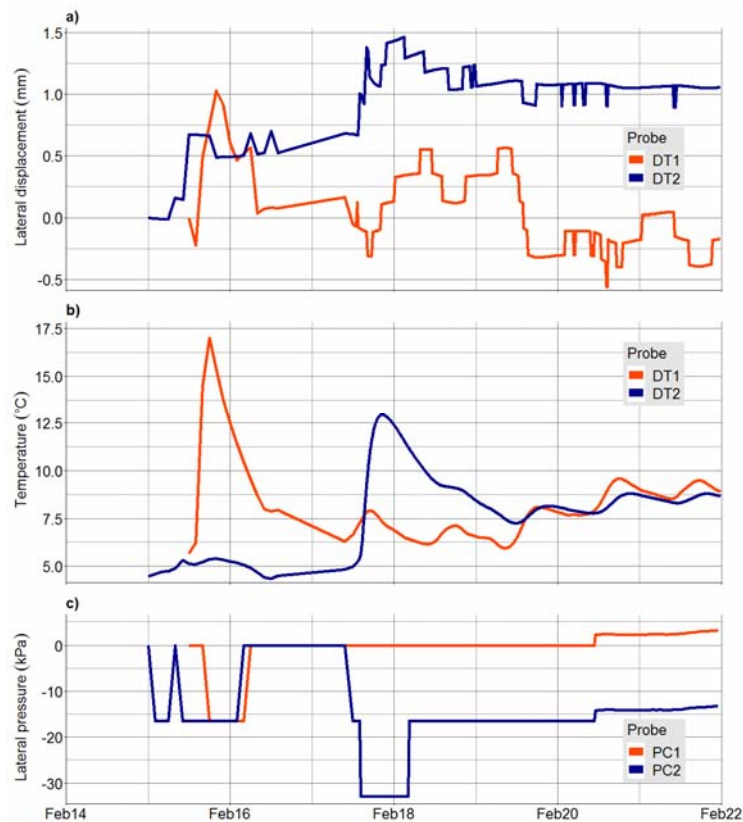
### 4.2.3 Trench wall monitoring

Displacement transducers and vertical pressure cells installed against the trench wall in Trench 1 were designed to provide information on the potential movement occurring at the edge of the excavated area during the construction of the nearby trench (i.e. Trench 2). This was an attempt to investigate the impact of a nearby OCS on a trench. Horizontal displacement transducers and vertical pressure cells (respectively, DT1, DT2 and PC1, PC2 in Figure 3) were buried at a shallow depth immediately below the asphalt layer between 0.10 m and 0.25 m from the surface (see Section 3.1). The measured data of the lateral displacement (DT sensors) and lateral pressure (PC sensors) were quite erratic, as shown in Figure 14a and c, respectively. At least part of the measured variability was associated with temperature variations. This is obvious in Figure 14b, where two temperature spikes were

recorded by the same sensors (Figure 14b only shows the temperature measured by the DT sensors, but the values were consistent with the measurements by the PC sensors) corresponding to the times when the asphalt was laid for Trench 1 (large spike in Figure 14b) and for Trench 2 (large blue spike in Figure 14b). Both the displacement transducers (Figure 14a) and the pressure cells (Figure 14c) were affected by these more extreme changes in temperature.

Despite the uncertainty, these results confirm that no significant lateral displacement or change in lateral pressure was measured during the construction phase of the nearby trench. This could be due to the difficulty of measuring these parameters in the field. These sensors require a good contact with the surrounding medium but this is not easy to achieve in coarse materials, and was especially true for the pressure cells that were installed in a vertical configuration. It is also possible that despite the two trenches were excavated in a V configuration (see Figure 3) they were still too far apart for the trenching operations on one trench to affect the instrumented area in the adjacent trench.

The distance between sensors and the other trench wall was 1.4 m, 3.3 m, 2.1 m and 5 m for DT1, DT2, PC1 and PC2, respectively. Assuming that these results are reliable, they indicate that the zone of influence of trenching operations is relatively small and that no significant disruption occurs at a greater distance during the construction phase. These findings are in line with previous studies which suggested a range between 0.5 m to 1 m for the zone of influence around trench (Lee and Lauter, 1999; Steele *et al.*, 2003; Jensen *et al.*, 2005; Stevens *et al.*, 2010). It is important, however, to note that these results relate to the specific conditions found at this site (including the trenching operations) and that the zone of influence could be larger in other situations. The FWD (Figure 10b) and total station (Figure 11) surveys indeed suggest the presence of a weaker zone that extends potentially up to 0.5 m from the excavated section. However, this weakened zone did not cause detectable lateral movement or any noticeable changes in lateral pressure in the nearby trench (note that Figure 14c shows drops in pressure down to -30 kPa, but these are linked to the large temperature increase during the asphalt placing operations, Figure 14b, and are unlikely to indicate an actual change in pressure). The long-term data from the displacement transducers and pressure cells contained significant noise and did not show clear trends over time.



**Figure 14: Monitoring of the Trench 1 wall during the construction of the nearby trench: (a) Lateral displacement (mm) and (b) temperature (°C) measured by the DTs, and (c) lateral pressure (kPa) measured by the PCs**

## 5 Discussion

The surface infrastructure (the road) and buried infrastructure (pipes and services) are interconnected via the ground (often ignored, but in this context also an important infrastructure). Therefore, when considering an intervention on one, the potential impact on the others should be considered. For example, a trench excavation to fix a buried pipe has an impact on the road structure and the surrounding ground. This interaction means that the condition of one infrastructure has an impact on the health of the others.

Furthermore, a deteriorated road can transfer excessive traffic loading to a buried water pipe, ultimately cracking the pipe, leading to leakage that can soften the surrounding ground and causing further damage to the road. Therefore, any required intervention should consider the interaction between the various infrastructures to minimise the negative impact. Considering the interconnected infrastructure systems, and appreciating the aforementioned negative

impact, it would seem sensible to consider joint road occupation when conducting OCS by different buried utility and road maintenance teams, to help reduce the associated impacts (Nafi and Kleiner, 2009; Carey and Lueke, 2013; Moran *et al.*, 2017). As demonstrated in the presented field trial, the OCS to install the buried pipes had an impact on the road structure as evidenced from the FWD, PANDA and other survey results. In particular, the trial identified that even when OCS are conducted within the current specifications, there is a considerable range at the lower end of this specification where the results are extremely poor in terms of longevity of the road above the trench itself and also the adjacent road structure. Features such as the quality of compaction, appropriate sealing of the joints and choice of the material all played an important role in the performance of the reinstated road. It is even evident that the trench constructed to the best possible specification still created some issues with the potential long-term performance of the road structure. This shows the need to consider alternative methods of accessing the buried utilities, for example trenchless technologies, which despite having their own drawbacks is still a less harmful method (Knight *et al.*, 2004).

In addition, the valuable data collected from this trial from both the *in situ* instruments and the surface surveys can be used to investigate best practice and potential assessment methods. For example, the PANDA DCP results demonstrated it could determine the quality and hence likely performance of the trench reinstatement. The FWD, which is not normally associated with such assessments, also provided valuable information and demonstrates its potential, particularly if smaller, lower cost versions can be developed in the future. In addition, an innovative and experimental non-intrusive resistivity technique deployed at the site provided information on the asphalt conditions and was capable of detecting dry/wet areas. These quality control measures can be used to minimise the costs of road and buried utilities repairs and therefore save costs by extending the life of assets, potentially beyond the two years guarantee for reinstatements in the UK. Developing a historical database of survey information from OCS using such equipment would create a valuable resource for developing future specifications.

Strain gauge measurements just beneath the asphalt layer indicated deformation and hence load transfer below the road surface, which could have an impact on shallow buried services. While the infiltrated water from poorly sealed joints, combined with the poor compaction, resulted in greater deformation in Trench 1 (which could also soften the ground surrounding the pipe) as the infiltrated water reached the depth of 0.7 m and therefore affecting the entire road structure (Gould *et al.*, 2009; Rajeev and Kodikara, 2011; Clair and Sinha, 2014). It

should be noted that joint sealing process might be identified as a source of reducing skid resistance and therefore a hazard for road users including cyclists (Highways Agency, 1994, 3.1; BSI, 2015, 6.8.2).

Although the present trial contributed to the understanding of the interaction occurring when conducting OCS, particularly in relation to road structure and ground interaction, this is a complex system consisting of the road, the ground and the buried utilities, and there still remains a research gap that needs addressing in future studies. It is suggested that future research should investigate the impact of one controlled element (e.g. compaction energy) at a time, utilising sensor data from controlled trials combined with numerical modelling to predict the actual rates of deterioration. The authors believe that a change in perspective and approach is needed that considers the shallow subsurface in urban areas as an interconnected system. In particular, road structures and buried utilities should not be treated in isolation. The ground ultimately is the link between the surface and buried infrastructures and should also be considered when making assessments and interventions.

## **6 Conclusions**

This study investigated the impact of OCS construction, including compaction procedure, choice of material and joint sealing, on an interconnected infrastructure system. This was done experimentally by excavating and reinstating two trenches where one was constructed to the highest standards and the other to the minimum acceptable standard within the specification, i.e. with minimum compaction using as dug material and without sealing the trench joints. The key findings of this paper are as follows:

- Water ingress through the unsealed joints reached the depth of 0.7 m, showing the need to ensure appropriate joint sealing material and procedure.
- Poor compaction of recycled material without any quality control measures resulted in significant road structure deterioration and failure due to major settlements and the development of cracks and deflected areas, as was evidenced from a number of surveys, i.e. total station, FWD, PANDA and resistivity.
- PANDA surveys showed a lower increase in mean cone resistance for Trench 1 over the time (5.9 MPa compared to 10.8 MPa for Trench 2).
- The total station survey results over a period of 10 months showed significant settlement occurred over Trench 1, up to 70 mm at one point.



- FWD results for Trench 1 revealed large deflections (up to 2000 micron), while results on Trench 2 also confirm that even trenches constructed according to the current best practice and specification have a negative impact on the adjacent existing road structure.
- *In situ* strain gauges measured significantly higher microstrain results for Trench 1, up to 50%, during the heavy traffic period, caused by movement of the road structure, as a result of inadequate compaction.
- An attempt was made to investigate the impact of a nearby OCS on a trench, using *in situ* horizontal displacement transducers and vertical pressure cells, which did not find any significant impact, probably because the minimum 1.4 m distance between the two trench walls was not small enough to show any significant changes.
- Cracks developed in Trench 1 provide route for water ingress through the road structure, increasing the water content (as confirmed by TDR measurements) and softening the ground and further deteriorating the road structure.
- The developed innovative and experimental non-intrusive resistivity technique provided information on the asphalt conditions and was capable of detecting dry/wet areas.

The paper has demonstrated the importance of understanding the compaction quality (relative density) in OCS operations throughout the trench depth. As for compaction procedure, the focus of current specification in the UK (Department of Transport, 1991) is on controlling performance, e.g. minimum passes and lift thickness based on the compaction plant, its weight and the backfill material, rather than controlling the end-product. The trial showed that the quality control for compaction can be conducted with some simple methods, such as the PANDA DCP test. This simple but highly effective method can be used for checking reinstatement quality immediately after backfilling and prior to placing the surface layer. Such a device could be used as a spot check on selected trenches to ensure quality. Alternatively, FWD or the road non-contact electrical resistivity measurement can be used over an entire road network and avoids invasive measurements, which were both successfully tested in the trial.

The performance of the two trenches showed a huge difference between two adopted OCS methods, where Trench 2 performed much better than the Trench 1, which was reinstated according to the lower end of the UK specification. This shows the importance of adopting

quality control measures to bring the current practice for OCS closer to the highest standard and ensure less effect on the life span of the road.

This paper has presented important independent evidential data for practitioners and policy makers to help improve the current guidelines on OCS practice and buried infrastructure management, by emphasising the need to adopt robust quality control measures.

## 7 Acknowledgements

The authors appreciatively acknowledge support provided by the Engineering and Physical Science Research Council (EPSRC) through the grants EP/F065973 (Mapping the Underworld), EP/K021699/1 (Assessing the Underworld) and EP/N010523/1 (Balancing the Impact of City Infrastructure Engineering on Natural Systems using Robots). The authors would also like to show their gratitude to the Estate Office at University of Birmingham, Dynatest UK Limited, O'Brian Contractors Limited, and Corehard Limited for their help and support during the field trial.

## 8 References

- Alinizzi, M., S. Chen, S. Labi and A. Kandil (2018). "A Methodology to Account for One-Way Infrastructure Interdependency in Preservation Activity Scheduling." **Computer-Aided Civil and Infrastructure Engineering** 33(11): 905-925.
- Asphalt Industry Alliance (2016). Annual Local Authority Road Maintenance (ALARM). Bristol, UK, Asphalt Industry Alliance (AIA): 16.
- BSI (2015). BS 594987:2015+A1:2017 Asphalt for roads and other paved areas. Specification for transport, laying, compaction and product type testing protocols. London, UK, BSI Standards Publication.
- Burtwell, M.H. and C.C. Spong (1999). The effectiveness of the utility reinstatement specification. **TRL Report 324**. Crowthorne:, TRL Limited.
- Carder, D.R. and M.E. Taylor (1983). Response of a pipeline to nearby deep trenching in boulder clay. Crowthorne, UK, Transport and Road Research Laboratory: 24.
- Carey, B.D. and J.S. Lueke (2013). "Optimized holistic municipal right-of-way capital improvement planning." **Canadian Journal of Civil Engineering** 40(12): 1244-1251.
- Cawsey, D.C. and S.W. Massey (1988). "In service deterioration of bituminous highway wearing courses due to moisture-susceptible aggregates." **Engineering Geology** 26(1): 89-99.
- Chow, C. and V. Troyan (1999). "Quantifying damage from utility cuts in asphalt Pavement by using San Francisco's Pavement Management data." **Transportation Research Record: Journal of the Transportation Research Board**(1655): 1-7.

- Chua, K. (1988). **Determination of CBR and elastic modulus of soils using a portable pavement dynamic cone penetrometer**. Proceedings of the First Symposium on Penetration Testing ISOPT-1, Orlando, USA.
- Clair, A.M.S. and S. Sinha (2014). "Development of a Standard Data Structure for Predicting the Remaining Physical Life and Consequence of Failure of Water Pipes." **Journal of Performance of Constructed Facilities** **28**(1): 191-203.
- Clarke, B.G., D. Magee, V. Dimitrova, A. Cohn, H. Du, Q.-a. Mahesar, A.M. Sadeghioon, C.D.F. Rogers, D. Gunn and D. Enwisle (2017). **A decision support system to proactively manage subsurface utilities**. To be confirmed, Leeds.
- Corehard. (2013). "Panda Penetrometer Testing." Retrieved 16/01/2019, from <http://www.corehard.com/services/panda-penetrometer-testing/>.
- Department for Transport (2012). New Roads and Street Works Act 1991; Code of Practice for the Co-ordination of Street Works and Works for Road Purposes and Related Matters. London, The Stationery Office: 167.
- Department of Transport (1991). New Roads and Street Works Act 1991; Code of Practice, Third Edition (England) April 2010 **Specification for the Reinstatement of Openings in Highways**. London, Highway Authorities and Utilities Committee, HAUC, The Stationery Office: 224.
- Dunn, J.R. and P.P. Hudec (1972). "Frost and sorption effects in argillaceous rocks." **Highway Research Record** **1972**(393): 65-78.
- Dynatest. (2018). "Falling Weight Deflectometer (FWD)." Retrieved 16/01/2019, from <https://www.dynatest.com/falling-weight-deflectometer-fwd>.
- Fleming, P.R. and M.R. Cooper (1995). "Investigations into the settlement characteristics of trench reinstatements." **Proceedings of the Institution of Civil Engineers - Municipal Engineer** **109**(2): 112-119.
- Frost, M.W. (2000). **The performance of pavement foundations during construction**. Doctoral Thesis Loughborough University, UK.
- Gould, S., F. Boulaire, D. Marlow and J. Kodikara (2009). **Understanding how the Australian climate can affect pipe failure**. Ozwater 09, 16-18 March 2009, Melbourne Convention & Exhibition Centre, Melbourne, Australia, <http://eprints.qut.edu.au>.
- Highways Agency (1994). Volume 2 Section 3 - Part 6 BD 33/94 - Expansion Joints for Use in Highway Bridge Decks. London, The Stationery Office.
- Jensen, K.A., V.R. Schaefer, M.T. Suleiman and D.J. White (2005). **Characterization of utility cut pavement settlement and repair techniques**. Proceedings of the 2005 Mid-Continent Transportation Research Symposium, Iowa State University, Ames, Iowa.
- Knight, M., S. Tighe and A. Adedapo (2004). **Trenchless installations preserve pavement integrity**. 2004 Annual Conference of the Transportation Association of Canada Quebec, Canada.
- Krechowiecki-Shaw, C., I. Jefferson, A.C.D. Royal, G.S. Ghataora and I. Alobaidi (2016). "Degradation of soft subgrade soil from slow, large, cyclic heavy haul road loads: a review." **Canadian Geotechnical Journal** **53**(9): 1435-1449.
- Lamas-Lopez, F., Y.J. Cui, S. Costa D'Aguiar and N. Calon (2016). "Geotechnical auscultation of a French conventional railway track-bed for maintenance purposes." **Soils and Foundations** **56**(2): 240-250.
- Lee, S.Q.S. and K.A. Lauter (1999). Impact of utility trenching and appurtenances on pavement performance in Ottawa-Carleton. Ottawa, Ontario, Canada, Environment and Transportation Department, Regional Municipality of Ottawa-Carleton: 66.

- Macy, M. (2002). "Pavement Degradation: How Other Cities Are Dealing With It." **American Public Works Association (APWA) Reporter** 69(9).
- Matthews, J.C. and E.N. Allouche (2010). "A social cost calculator for utility construction projects." **North American Society for Trenchless Technology Paper F-4-03**: 1-10.
- Matthews, J.C., E.N. Allouche and R.L. Sterling (2015). "Social cost impact assessment of pipeline infrastructure projects." **Environmental Impact Assessment Review** 50: 196-202.
- McHale, M.J. (2013). Long-term damage to roads caused by utility reinstatements. **TRL Published Project Report**, Transport Research Laboratory; Conducted for the Scottish Road Works Commissioner (SRWC): 46.
- Metje, N., P.R. Atkins, M.J. Brennan, D.N. Chapman, H.M. Lim, J. Machell, J.M. Muggleton, S. Pennock, J. Ratcliffe, M. Redfern, C.D.F. Rogers, A.J. Saul, Q. Shan, S. Swingler and A.M. Thomas (2007). "Mapping the Underworld – State-of-the-art review." **Tunnelling and Underground Space Technology** 22(5–6): 568-586.
- Moran, J., M. Eskandari Torbaghan and M.P.N. Burrow (2017). "Estimating the Benefits of Joint Occupation for Street Works." **Infrastructure Asset Management** 4(4): 115-127.
- Nafi, A. and Y. Kleiner (2009). "Scheduling renewal of water pipes while considering adjacency of infrastructure works and economies of scale." **Journal of water resources planning and management** 136(5): 519-530.
- Nichols-Vallerga & Associates (2000). Impact of Utility Cuts on Performance of Seattle Streets, Final Report. Seattle, USA, City of Seattle, Seattle Transportation: 56.
- Rajeev, P. and J. Kodikara (2011). "Numerical analysis of an experimental pipe buried in swelling soil." **Computers and Geotechnics** 38(7): 897-904.
- Reynolds, J.M. (2011). **An introduction to applied and environmental geophysics**, John Wiley & Sons.
- Schaefer, V., M. Suleiman, D. White, C. Swan and K. Jensen (2005). Utility cut repair techniques; investigation of improved cut repair techniques to reduce settlement in repaired areas. Ames, Iowa, Iowa Highway Research Board: 159.
- Shahin, M., J. Croveti and J. Franco (1986). "The Effects of Utility patching on Pavement Performance and Rehabilitation Costs for City of Burlington, Vermont." **Proceedings of Transport Research Board**.
- Steele, D.P., M.H. Burtwell and W. McMahon (2003). Long-term performance of reinstated trenches and their adjacent pavements. part 2: long-term performance of reinstatements in the highway: 64.
- Stevens, L., M.T. Suleiman, V.R. Schaefer, H. Ceylan and K.A. Videkovich (2010). Investigation of Improved Utility Cut Repair Techniques to Reduce Settlement in Repaired Areas, Phase II, IHRB Project Number TR-566. Ames, Iowa, Iowa Highway Research Board: 314.
- The Highways Agency (2006). Part 3: Pavement Design. **Section 2: Pavement Design and Construction** London, UK, The Stationery Office. **HD 26/06**: 29.
- Watson, D. (1994). **Contouring: a guide to the analysis and display of spatial data**, Pergamon.