

## Mechanisms of immunogenicity in colorectal cancer

Sillo, T O; Beggs, A D; Morton, D G; Middleton, G

DOI:

[10.1002/bjs.11204](https://doi.org/10.1002/bjs.11204)

License:

Creative Commons: Attribution (CC BY)

*Document Version*

Publisher's PDF, also known as Version of record

*Citation for published version (Harvard):*

Sillo, TO, Beggs, AD, Morton, DG & Middleton, G 2019, 'Mechanisms of immunogenicity in colorectal cancer', *British Journal of Surgery*, vol. 106, no. 10, pp. 1283-1297. <https://doi.org/10.1002/bjs.11204>

[Link to publication on Research at Birmingham portal](#)

### General rights

Unless a licence is specified above, all rights (including copyright and moral rights) in this document are retained by the authors and/or the copyright holders. The express permission of the copyright holder must be obtained for any use of this material other than for purposes permitted by law.

- Users may freely distribute the URL that is used to identify this publication.
- Users may download and/or print one copy of the publication from the University of Birmingham research portal for the purpose of private study or non-commercial research.
- User may use extracts from the document in line with the concept of 'fair dealing' under the Copyright, Designs and Patents Act 1988 (?)
- Users may not further distribute the material nor use it for the purposes of commercial gain.

Where a licence is displayed above, please note the terms and conditions of the licence govern your use of this document.

When citing, please reference the published version.

### Take down policy

While the University of Birmingham exercises care and attention in making items available there are rare occasions when an item has been uploaded in error or has been deemed to be commercially or otherwise sensitive.

If you believe that this is the case for this document, please contact [UBIRA@lists.bham.ac.uk](mailto:UBIRA@lists.bham.ac.uk) providing details and we will remove access to the work immediately and investigate.

# Mechanisms of immunogenicity in colorectal cancer

T. O. Sillo<sup>1</sup> , A. D. Beggs<sup>2</sup>, D. G. Morton<sup>3</sup> and G. Middleton<sup>1</sup>

Institutes of <sup>1</sup>Immunology and Immunotherapy and <sup>2</sup>Cancer and Genomic Sciences, College of Medical and Dental Sciences, University of Birmingham, and <sup>3</sup>Academic Department of Surgery, College of Medical and Dental Sciences, Queen Elizabeth Hospital, Birmingham, UK

Correspondence to: Ms T. O. Sillo, Room WX2.72, Institute of Biomedical Research (West), College of Medical and Dental Sciences, Vincent Drive, University of Birmingham, Edgbaston, Birmingham B15 2TT, UK (e-mail: t.sillo@bham.ac.uk)

**Background:** The immune response in cancer is increasingly understood to be important in determining clinical outcomes, including responses to cancer therapies. New insights into the mechanisms underpinning the immune microenvironment in colorectal cancer are helping to develop the role of immunotherapy and suggest targeted approaches to the management of colorectal cancer at all disease stages.

**Method:** A literature search was performed in PubMed, MEDLINE and Cochrane Library databases to identify relevant articles. This narrative review discusses the current understanding of the contributors to immunogenicity in colorectal cancer and potential applications for targeted therapies.

**Results:** Responsiveness to immunotherapy in colorectal cancer is non-uniform. Several factors, both germline and tumour-related, are potential determinants of immunogenicity in colorectal cancer. Current approaches target tumours with high immunogenicity driven by mutations in DNA mismatch repair genes. Recent work suggests a role for therapies that boost the immune response in tumours with low immunogenicity.

**Conclusion:** With the development of promising therapies to boost the innate immune response, there is significant potential for the expansion of the role of immunotherapy as an adjuvant to surgical treatment in colorectal cancer.

Paper accepted 12 March 2019

Published online in Wiley Online Library (www.bjs.co.uk). DOI: 10.1002/bjs.11204

## Introduction

The tumour microenvironment in colorectal cancer is influenced by somatic mutational and epigenetic events that occur during tumour development, as well as by the host immune system, which exerts negative selection pressures on tumour cells, by recognition of tumour antigens as non-self<sup>1</sup>. Immune checkpoints are a series of innate and adaptive regulatory mechanisms to modulate immune activity and promote tolerance to self-antigens. These can be upregulated in tumours to drive resistance to immune cell-mediated destruction<sup>2,3</sup>. Immunotherapy has been most successful in targeting and blocking these immune checkpoints, leading to effective antitumour responses in some cancers<sup>4</sup>.

The emergence of immunotherapy has transformed the treatment landscape of some cancers, most notably cutaneous melanoma<sup>5,6</sup> and non-small cell lung cancer (NSCLC)<sup>7,8</sup>. So far, the role of immunotherapy in colorectal cancer been limited to the 3–4 per cent of patients with metastatic disease whose tumours demonstrated microsatellite instability (MSI)<sup>9</sup>, due to germline, somatic

or epigenetic inactivation of DNA mismatch repair (MMR) genes<sup>10</sup>. However, its role could be expanded significantly by drawing on an understanding of the immunogenomic drivers of the response in the tumour environment.

This review explores current understanding of the relative contributions of innate immune genomic mechanisms and somatic mutations to the immune environment in colorectal cancer, with the implications for potential expansion of the roles of immunotherapy and other targeted therapies in the management of colorectal cancer at all disease stages.

## Methods

### Search strategy

A literature search was conducted using the PubMed, MEDLINE and Cochrane Library databases, as well as reference lists from appropriate papers. The goal was to provide an overview of published research in the field of colorectal cancer genomics and immunology, with a particular focus on advances since the launch of the

genomics era after completion of the Human Genome Project<sup>11</sup>. The following keywords were used to perform flexible searches within these databases: ‘immunotherapy’, ‘colorectal’ AND ‘cancer’, ‘mutation’, ‘immunity’ and ‘immunologic adjuvants’. Only papers published in English were included.

## Structure

An overview of the role of MSI in colorectal cancer in delineating clinical outcomes and the response to immunotherapy is presented, followed by an in-depth consideration of current understanding of the determinants of the colorectal tumour environment, including tumour mutational factors, inherited germline determinants and the potential role of the gut microbiome. The implications of immune heterogeneity in colorectal cancer and clinical applications for immunotherapeutic approaches are considered. There is a strong argument for routine testing and treatment of patients with colorectal cancer based primarily on immunogenomic rather than histopathological markers.

## Microsatellite instability in colorectal cancer

Approximately 15 per cent of patients with colorectal cancer have tumours that demonstrate MSI, secondary to deficient MMR (dMMR). MSI – high (MSI-H) tumours are characterized by a high mutational burden and the generation of large numbers of neoantigens, which trigger powerful anticancer host immune responses<sup>12–14</sup>. In contrast, the 85 per cent of colorectal cancers that develop owing to chromosomal instability, termed microsatellite stable (MSS)<sup>15</sup>, has a much lower mutational burden and smaller numbers of neoantigens.

More than two variants of MSI-H colorectal cancer have been demonstrated<sup>10,16</sup>. Hereditary non-polyposis colonic cancer or Lynch syndrome is found in 3 per cent of colorectal cancers. It is caused by an inactivating germline mutation of one or more of the DNA MMR genes (*MLH1*, *MSH2*, *MSH6* and *PMS2*), with a second hit from a sporadic mutation, loss of heterozygosity or epigenetic silencing of a second MMR gene<sup>10</sup>. These patients have a 50–70 per cent lifetime risk of colorectal cancer, as well as significant lifetime risks of endometrial cancer (in women), and other intestinal and urothelial cancers<sup>17</sup>. More commonly, MSI-H tumours have no underlying germline mutations, and arise as a consequence of epigenetic silencing of the MMR gene *MLH1* by hypermethylation of its promoter region<sup>18</sup>. Sporadic MSI-H colorectal cancer is frequently associated with the v-raf murine sarcoma viral oncogene

homolog B1 (*BRAF*) V600E mutation, through its association with the CpG island methylator phenotype.

*BRAF* is a downstream molecule in the Rat sarcoma protein (Ras)–mitogen-associated protein kinase (MAPK) signalling pathway, which is critical for cell survival and proliferation<sup>19</sup>. *BRAF* mutations are present in both sporadic MSI-H and MSS colorectal cancers but mostly absent in Lynch syndrome, and so the presence of a *BRAF* mutation, in conjunction with *MLH1* methylation analysis, reliably distinguishes between sporadic MSI-H colorectal cancer and Lynch syndrome<sup>20</sup>. A third variant, Lynch-like syndrome, is less well characterized. Lynch-like colorectal tumours have no germline MMR gene mutations or hypermethylation of the *MLH1* promoter<sup>21</sup>, suggesting other unknown somatic mutations within MMR genes as the cause of MSI<sup>10</sup>. The revised Bethesda guidelines for Lynch syndrome diagnosis<sup>22</sup> take into account both clinical information (including diagnosis at a young age and strong family history) and assessment of MSI status by immunohistochemistry or genomic analysis.

MSI-H colorectal cancers have clinicopathological features distinct from those of MSS tumours, including an increased incidence in female patients, more proximal colonic location, high lymphocyte infiltration levels and lower incidence of metastasis, with better clinical prognosis at stage I–III<sup>13,23</sup>. A nationwide study<sup>24</sup> of 6692 patients by the Danish Colorectal Cancer Group revealed a reduced risk of synchronous metastases in patients with dMMR colorectal cancer (8.0 *versus* 15.8 per cent; odds ratio 0.54). There was also an inverse association between dMMR status and lymph node metastasis and venous invasion. However, in metastatic (stage IV) disease, MSI appears to confer a worse prognosis<sup>25</sup>.

MMR loss is associated with the rapid accumulation of mutations. Timmermann and colleagues<sup>26</sup> performed whole-exome sequencing (WES) of MSI and MSS colorectal cancers in two patients, and found 1304 somatic mutations in the MSI tumour compared to 198 in the MSS lesion. In addition to base substitutions, large numbers of insertions and deletions occur<sup>20</sup>. They may lead to frameshifts which, if occurring in tumour suppressor genes, can drive tumorigenesis. High mutation rates generate large numbers of new peptides, termed neoantigens, which are not recognized as self and thus are strongly immunogenic. Neoantigens contribute to a better prognosis in MSI colorectal cancer owing to the increased infiltration of effector cells (primarily effector T cells<sup>27</sup>) into the tumour environment<sup>13,23</sup>.

Other mechanisms may also contribute towards immunogenicity in MSI-H colorectal cancer. Constitutive

activation of the viral response cyclic guanosine–adenosine 3',5'-cyclic monophosphate synthase–stimulator of interferon genes (cGAS-STING) pathway, with associated T cell infiltration, occurs in DNA damage response-deficient breast cancers<sup>28</sup>. cGAS is activated by DNA damage and localizes to micronuclei that form during tumorigenesis<sup>29</sup>. This triggers a proinflammatory response. Deficiency in the MMR protein MLH-1 is associated with deficient DNA double-strand break repair and increased micronuclei formation<sup>30</sup>, which may also trigger the cGAS-activated inflammatory response.

Current immunotherapeutic approaches serve primarily to block immune checkpoints, boosting immune-mediated tumour destruction<sup>31</sup>. Patients with dMMR metastatic colorectal cancer have been shown to have significant clinical responses to immunotherapy with antiprogrammed cell death 1 (PD-1)/antiprogrammed cell death ligand 1 (PD-L1) treatment in phase II trials<sup>21</sup>, in stark contrast to those in the MSS colorectal cancer subgroup where there was no objective response to immunotherapy<sup>32</sup>. Yarchoan and co-workers<sup>33</sup> demonstrated a strong correlation between tumour somatic mutation frequency (and therefore neoantigen burden) and the response to immunotherapy across a range of human cancer subtypes.

However, MSI status and neoantigen burden do not sufficiently explain the variability in the colorectal tumour environment. About 20 per cent of patients in the MSS colorectal cancer subgroup develop an immunogenomic signature similar to that in MSI-H colorectal cancer, despite low mutational burden<sup>34</sup>. There is evidence that activating mutations in the Ras–MAPK pathway are associated with lower expression of this immune gene cluster and immune pathway downregulation<sup>35–37</sup>. In addition, lymphocytic infiltration, particularly of effector and memory T cells into the tumour, a key indicator of prognosis in colorectal cancer<sup>27,38</sup>, appears to be independent of MSI status<sup>39</sup>.

### Colorectal cancer tumour microenvironment

Various mechanisms lead to immunosuppression in colorectal cancer. Recruitment of immunoregulatory cells<sup>40</sup>, upregulation of inhibitory molecules (including myeloid-derived suppressor cells (MDSCs), T regulatory (Treg) cells, type 2 macrophages and other cancer-associated cell types<sup>2,41–43</sup>) and downregulation of antigen presentation represent methods of immune evasion<sup>44</sup>. The alteration of metabolic pathways to favour glycolysis, even in the presence of sufficient oxygen, is termed the Warburg effect<sup>45</sup>. This, along with the upregulation of anabolic pathways that favour rapid

tumour cell survival and proliferation, often leads to the generation of an environment that is hostile to T cells owing to increased acidity, low oxygen levels, competition for nutrients and the generation of waste substrates<sup>44,46</sup>. In this context, T cell exhaustion occurs, defined as the presence of T cells with decreased cytokine expression and effector function<sup>47,48</sup>.

Activated T cells express inhibitory co-receptors, termed immune checkpoints. The best characterized include PD-1, cytotoxic T lymphocyte-associated protein 4, lymphocyte-activation gene 3, T cell immunoglobulin mucin 3 (Tim-3) and killer immunoglobulin-like receptors. When they bind to ligands present on antigen-presenting cells and other cells in the immune environment, they downgrade the inflammatory response<sup>42</sup>. This serves as an innate mechanism to maintain self-tolerance and limit immune-mediated tissue damage.

Selective upregulation of these immune checkpoints is often present in MSI-H tumours (*Fig. 1*). This may explain why MSI-H tumours are not eliminated naturally despite high immune activation, and why checkpoint blockade is effective in these tumours. Tumour infiltrating lymphocytes (TILs) in MSI-H colorectal cancer express high levels of PD-1, which is absent in MSS colorectal cancer. However, corresponding expression of immune checkpoint ligands is often absent on tumour cells, and found to be present on a population of infiltrating myeloid cells<sup>31</sup>. Immature populations of myeloid cells (MDSCs) are present in most tumours and are induced in the presence of cancer cells<sup>49</sup>. The upregulation of PD-L1 on these cells suggests a direct interaction with T cells. They also appear to increase toxic cell metabolite production and induce Treg activity, which further suppress effector cell activity<sup>49</sup>. Tim-3, which blocks T helper responses, is often upregulated on exhausted CD4+ and CD8+ TILs in colorectal cancer in combination with PD-1<sup>50</sup>. This correlates with regional metastases and poorer prognoses in both colorectal cancer and other solid tumours<sup>51,52</sup>.

Clinicopathological data strongly suggest that effector T cells in the tumour microenvironment are key determinants of outcomes. Patients with large TIL numbers have improved survival at all disease stages. This prognostication is superior to that of the UICC TNM classification by disease stage<sup>53</sup>. Galon *et al.*<sup>54,55</sup> developed an immunocytochemical score for the colorectal cancer immune microenvironment, the Immunoscore® (HalioDx, Marseille, France). It is based on the finding that the infiltration of cytotoxic (CD8+) and memory (CD45RO+) T cells is associated with improved prognosis. The densities of CD45RO+ and CD8+ cells in the centre of the tumour (CT) and invasive margin (IM) are used to stratify patients

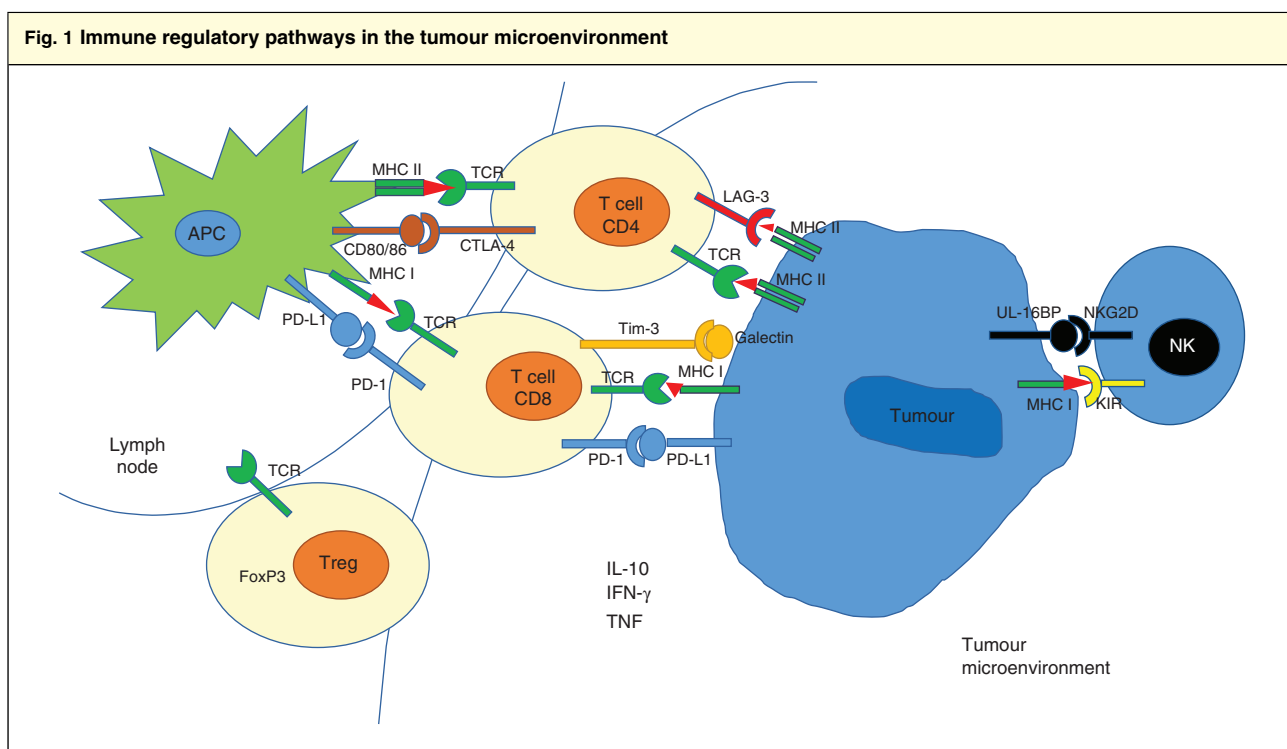

Adapted from Postow *et al.*<sup>42</sup> and Wachowska and colleagues<sup>43</sup>. APC, antigen-presenting cell; CTLA-4, cytotoxic T lymphocyte-associated protein 4; FoxP3, forkhead box P3; IFN- $\gamma$ , interferon  $\gamma$ ; IL-10, interleukin 10; KIR, killer immunoglobulin-like receptor; LAG-3, lymphocyte activation gene 3; NK, natural killer cell; NKG2D, natural killer G2D receptor; PD-1, programmed cell death 1 protein; PD-L1, programmed cell death 1 ligand; TCR, T cell receptor complex; Tim-3, T cell immunoglobulin mucin 3; TNF, tumour necrosis factor; Treg, regulatory T cell; UL16BP, UL16-binding proteins.

into distinct populations with significantly different clinical outcomes at all disease stages<sup>53</sup>. In multivariable analysis, after adjusting for tumour category, differentiation, lymph node invasion and other molecular biomarkers including microsatellite status and *BRAF* mutation status, T cell infiltration ( $CD3_{CT}/CD3_{IM}$ ) remained an independent prognostic factor for disease-free survival (DFS) and overall survival (OS).

The ImmunScore<sup>®</sup> was independently validated by the Society for the Immunotherapy of Cancer worldwide consortium study<sup>56,57</sup>, in 2681 patients from 14 centres across 13 countries. Similarly, in a study<sup>39</sup> across three cohorts, including 270 colorectal cancer and 3659 pan-cancer samples from the Cancer Genome Atlas, the ImmunScore<sup>®</sup> was a better predictor of disease-specific survival, DFS and OS than microsatellite status.

Other immune cells contribute to the immune environment. Natural killer (NK) cells are critical in the innate immune response and have spontaneous cytotoxic effects against aberrant cells. There appears to be a decrease in NK cell activity in patients with colorectal cancer compared with healthy controls<sup>58</sup>. In addition, infiltration of NK cells into colorectal tumours appears to be associated with

better clinical outcomes. In metastatic disease, both a high proportion of NK cells in peripheral blood and increased NK cytotoxicity are associated with increased responses to chemotherapy and longer survival<sup>59,60</sup>. However, their interactions with T cells and prognostic significance are not yet understood. Dendritic cells are key antigen-presenting cells with a central role in the initiation and regulation of adaptive immunity. They prime antitumour responses by presenting tumour antigens to T cells and through interactions with other effector cells. Impairment in dendritic cell function occurs in many cancer models and represents a mechanism of immune escape<sup>61</sup>. They also express immune checkpoint ligands, including PD-L1 and CD80/86<sup>62</sup>.

Another mechanism for immunosuppression is the loss of MHC class I and II proteins from cell surfaces. They are required for antigen presentation to T cells and other effector cells. Class I loss is frequent in MSI-H colorectal cancer (60 per cent of cases *versus* 17 per cent of MSS colorectal cancers<sup>63</sup>). Class II expression is more nuanced. It is expressed in up to 50 per cent of colorectal cancers. Subsequent loss of class II expression correlates with reduced TIL density and increased incidence of regional metastases<sup>64</sup>. In melanoma, class

II-negative patients had lower objective response and survival rates when treated with anti-PD-1/PD-L1 immunotherapy<sup>65</sup>. Mouse cancer models suggest that induction of class II expression in colorectal cancer may improve tumour immunogenicity. Transfection of the master transcriptional activator of class II (CIITA) into poorly immunogenic class II-negative adenocarcinoma cell lines resulted in these cells developing robust antigen-processing function, with massive infiltration by both CD4+ and CD8+ T cells, and tumour rejection occurred when the CIITA-transfected cell lines were infused into mice<sup>66,67</sup>.

Although immune cell quantification methods such as the Immunoscore<sup>®</sup> give a phenotypic output of the colorectal cancer immune environment, the relative contributions of germline, somatic and epigenetic variations in the immune signature to this microenvironment have not been determined. A key question is what drives the presence of large numbers of TIL in some tumours and not others. It is clear that somatic mutational factors alone are not sufficient to explain this variability.

### Implications of immune heterogeneity in colorectal cancer

Colorectal cancer can be divided into four consensus molecular subtypes (CMS), each with distinguishing pathological features<sup>68</sup>. The MSI-H group represents CMS1, showing hypermutation and strong immune activation; CMS2 (canonical) shows chromosomal instability with marked Wnt and myc signalling; CMS3 (epithelial) shows metabolic dysregulation; and CMS4 (mesenchymal) shows prominent transforming growth factor  $\beta$  activation, stromal invasion and angiogenesis. This subtype demonstrates strong immune cell infiltration.

In a recent study<sup>34</sup> using a T helper-1 centric immune metagene as a marker of the immune contexture, 20 per cent of patients in the MSS colorectal cancer subgroup had an immune signature very similar to that of MSI-H colorectal cancer, despite small numbers of mutations and fewer neoantigens<sup>34</sup>. This group segregated to the CMS4 subtype. The Kirsten ras sarcoma oncogene (*KRAS*) mutation, especially in the CMS2 and 3 subtypes, is associated with downregulation of immune pathways and reduced immune cell infiltration<sup>35</sup>. *KRAS* mutation, apart from predicting non-response to anti-epidermal growth factor receptor (EGFR) chemotherapy, is independently associated with a worse prognosis in colorectal cancer<sup>69</sup>.

*KRAS* and *BRAF* are downstream molecules in Ras–MAPK signalling, which is a critical mediator of EGFR-induced signalling cascades<sup>70</sup>. Mutations that cause

dysregulation and hyperactivation of this pathway<sup>71</sup> may be implicated in suppression of immunogenicity in colorectal cancer. In a study of triple-negative breast cancer, which is associated with early metastasis and a worse prognosis than other variants, alterations in Ras–MAPK signalling correlated with low TIL numbers, which correlated with worse recurrence-free survival. Using *in vitro* and *in vivo* mouse-derived breast cancer cell lines, inhibition of MAPK kinase (MEK), another downstream molecule in the MAPK signalling cascade, upregulated both MHC class I and II and PD-L1. Combined PD-1/PD-L1 and MEK inhibition enhanced antitumour immune responses<sup>37</sup>.

Lochhead and colleagues<sup>25</sup> undertook a prospective observational analysis of the impact of *BRAF* mutation status and MSI on 5-year cancer-specific survival in 1253 patients with colorectal cancer. Patients with the MSI-H/*BRAF* wild-type subtype had the highest survival rate (79 per cent), whereas those with the MSS/*BRAF* mutant subtype (46 per cent) had the poorest survival. MSI-H/*BRAF* mutant and MSS/*BRAF* wild-type subtypes had intermediate values (73 and 65 per cent respectively) with no direct interaction between MSI and *BRAF* status. A pooled analysis<sup>72</sup> of four phase III studies of first-line treatment of metastatic colorectal cancer showed a higher incidence of the *BRAF* mutation in metastatic MSI colorectal cancer. Although the *BRAF* mutation was independently associated with a worse prognosis, subanalysis of the MSI-H and MSS colorectal cancer subgroups established no difference in survival in *BRAF* mutant and *BRAF* wild-type MSI-H colorectal cancers. Metastatic Lynch and Lynch-like colorectal cancers (in which *BRAF* mutations are largely absent) have increased DFS and OS compared with sporadic MSI colorectal cancer, although the typically younger age of patients with Lynch syndrome is a confounding factor<sup>16</sup>.

Large phase III clinical trials<sup>73,74</sup> support a combination of *BRAF* and MEK inhibition in melanoma. Disappointingly, these results were not replicated in combination trials in *BRAF*-mutated colorectal cancer<sup>75</sup>, likely due to the development of escape mechanisms. One possibility is the heterodimerization of *BRAF* with *CRAF*, a *BRAF* isoform, which drives increased Ras–MAPK signalling<sup>76</sup>, and has been noted in the development of resistance and secondary tumours following *BRAF* inhibition in metastatic melanoma<sup>77,78</sup>.

### Role of neoantigens in cancer immunotherapy

During tumour evolution, driver mutations, which cause the transformations required for tumorigenesis and tumour propagation, and passively acquired passenger mutations

occur. Neoantigens arise as a result of non-synonymous somatic mutations during tumour evolution<sup>79</sup>. They may be clonal (expressed in all tumour cells) or subclonal (expressed in a proportion of tumour cells). Tumours harbouring large numbers of subclonal mutations have a variety of cell populations with different genomic and, therefore, phenotypic signatures<sup>80</sup>. Neoantigen clonality plays a role in determining the likelihood of a durable response to immunotherapy. In a series of NSCLC samples from the Cancer Genome Atlas<sup>80</sup>, patients with tumours with high levels of subclonal mutations (and therefore low neoantigen clonality) had no durable clinical benefit from immunotherapy, irrespective of the neoantigen load. Similarly, in a study<sup>81</sup> demonstrating the predictive power of mutational burden for response to pembrolizumab, an anti-PD-1 inhibitor, its efficacy was dependent on neoantigen clonality. Tumours with similar neoantigen numbers responded significantly more favourably if neoantigens were clonal than if they were subclonal.

The most potent T cell responses are against neoantigens<sup>82</sup>. As the pattern of mutations is highly variable, and the cancer genome is unique to each individual, identification of neoantigens was challenging initially. With the development of next-generation sequencing and bioinformatics strategies for *in silico* prediction, it is now possible to rapidly identify and filter neoantigens<sup>83–85</sup>. WES of tumour samples allows identification of somatic mutations, which are modelled using a protein prediction algorithm<sup>86</sup> and fed into an MHC-binding predictor to model the MHC-binding capacity<sup>87–89</sup>. Structural variants (in particular, gene fusions that may also generate neoantigens) are more difficult to identify from WES unless RNA sequencing data are available<sup>90</sup>.

Proposed advantages of targeted cancer immunotherapy include increased efficacy and specificity, resulting in lower toxicity than current treatments. Current approaches involve either boosting the T cell response to tumour neoantigens (adoptive cell transfer and checkpoint blockade are examples of this) or altering the neoantigen landscape to favour the expression of those that are highly immunogenic<sup>90</sup>. Adoptive cell transfer of T cells recognizing certain tumour antigens has been shown to induce tumour regression in some trials, most notably in melanoma<sup>91</sup>. In a clinical trial<sup>92</sup> in three patients with melanoma, WES was used to identify the highest binding epitope peptides and these patients were vaccinated with autologous dendritic cells that had been pulsed with the top seven highest binding peptides identified from each tumour. This led to an increase in the breadth and diversity of neoantigen-specific T cells from all patients, who were alive with no adverse autoimmune events at the time of

reporting. The potential for use in solid tumours, such as breast cancer, is being explored<sup>93</sup>.

Tumour neoantigens are ideal targets for cancer immunotherapy, as they are expressed only in tumour cells and so are less likely to induce either immunological tolerance or toxicity from targeted therapy. However, targeting specific neoantigens may lead to tumour escape via expansion of subclonal populations. It remains uncertain whether cancer vaccination is potent enough to induce remission in solid tumours. Other limiting factors include the significant financial implications inherent in developing personalized treatments, and the possibility of significant adverse reactions. Nevertheless, there are encouraging results from initial studies, and refinements in neoantigen targeting and vaccine delivery are ongoing.

### Applications of immunotherapy in colorectal cancer

Phase I trials of immunotherapy in patients with advanced colorectal cancer showed poor results, with little objective clinical response or improvement in outcomes<sup>94,95</sup>. However, further studies showed clear differences in those with dMMR/MSI-H colorectal cancer. Le *et al.*<sup>32</sup> compared outcomes in patients with or without dMMR colorectal cancer who were given pembrolizumab. The immune-related objective response rate (ORR) was 40 per cent and the progression-free survival (PFS) rate 78 per cent in patients with dMMR, compared with 0 and 11 per cent respectively in patients without dMMR. This was associated with a significantly reduced risk of death or disease progression (hazard ratio 0.22) in the dMMR group. High levels of somatic mutations also correlated with improved survival<sup>32</sup>.

Current trials<sup>9,96</sup> have not shown significant differences in ORR and disease control in Lynch *versus* non-Lynch-associated tumours. Le and colleagues<sup>96</sup> observed no significant difference in ORR, determined radiologically and clinically, between Lynch and non-Lynch syndrome-associated MSI-H tumours (46 and 59 per cent respectively;  $P=0.27$ ). In the Keynote-142 phase II open-label trial<sup>9</sup> of nivolumab, an anti-PD1 antibody, in patients with metastatic MSI-H colorectal cancer who had been unable to tolerate previous chemotherapy or whose disease had progressed, ORR and disease control rates were similar in Lynch *versus* non-Lynch MSI-H colorectal cancer (33 *versus* 29 per cent, and 70 *versus* 75 per cent, respectively).

Based on data from five single-arm multicohort multicentre trials, in 2017 the US Food and Drug Administration<sup>97</sup> granted accelerated approval for use of the anti-PD-1

Reference (trial)	Phase	Regimen	Subgroups	Outcomes	Duration
Le <i>et al.</i> <sup>32</sup>	II	Pembrolizumab (PD-1 inhibitor)	dMMR/MSI-H versus MSS CRC	Immune-related objective response rate PFS	20 weeks
Overman <i>et al.</i> <sup>9</sup> (CheckMate 142)	II	Nivolumab (PD-1 inhibitor) +/- ipilimumab (CTLA-4 inhibitor)	Metastatic pretreated dMMR/MSI-H CRC	Immune-related objective response rate PFS OS	12 months
Mettu <i>et al.</i> <sup>99</sup> (BACCI)	II	Capecitabine/bevacizumab +/- atezolizumab (PD-L1 inhibitor)	Metastatic CRC	PFS OS	Ongoing
Hoffmann-La Roche <sup>100</sup> (COTEZO IMblaze370)	III	Cobimetinib + atezolizumab (PD-L1 inhibitor) versus atezolizumab monotherapy versus regorafenib	Heavily pretreated locally advanced or metastatic CRC (> 95% MSS)	OS PFS	3 years
Diaz <i>et al.</i> <sup>101</sup> (KEYNOTE-177)	III	Pembrolizumab (PD-1 inhibitor) versus standard chemotherapy	dMMR/MSI-H stage IV CRC	PFS OS	57 months
Asan Medical Centre <sup>102</sup> (POLE-M)	III	Standard 5-FU-based adjuvant chemotherapy +/- sequential avelumab (PD-L1 inhibitor)	Resected stage III dMMR/MSI-H or POLE-mutant colonic cancer	DFS	5 years
Sinicrope <i>et al.</i> <sup>103</sup> (ATOMIC, Alliance A021502)	III	Combination chemotherapy +/- atezolizumab (anti-PD-L1) continued as monotherapy for additional 6 months	Resected stage III dMMR/MSI-H colonic carcinomas	DFS OS Adverse events	5 years
Tabernero <i>et al.</i> <sup>104</sup>	I	CEA-TCB antibody +/- atezolizumab (anti-PD-L1)	Heavily pretreated metastatic CRC (mainly MSS)	Adverse events Antitumour activity (RECIST version 1.1 criteria <sup>105</sup> ) PFS	40 months

PD-1, programmed cell death protein 1; dMMR, deficient mismatch repair; MSI-H, microsatellite instability –high; MSS, microsatellite stable; CRC, colorectal cancer; PFS, progression-free survival; CTLA-4, cytotoxic T lymphocyte-associated protein 4; OS, overall survival; PD-L1, programmed cell death protein ligand 1; POLE-M, mutated DNA polymerase  $\epsilon$ ; 5-FU, 5-fluorouracil; DFS, disease-free survival; CEA-TCB, carcinoembryonic antigen–T cell-bispecific; RECIST, Response Evaluation Criteria in Solid Tumours.

inhibitor pembrolizumab in people with unresectable or MSI-H or dMMR solid tumours. Several ongoing clinical trials are assessing checkpoint blockade agents in colorectal cancer. Patients in these trials all have advanced or metastatic disease (MSI-H and MSS) and have been heavily pretreated<sup>32,98–103</sup> (Table 1).

Meta-analysis<sup>106</sup> of eight clinical trials of immunotherapy with PD-1/PD-L1 blockade has shown that the PD-L1 expression level in tumour samples has neither prognostic nor predictive significance in determining outcomes. These were studies of advanced urothelial and head-and-neck tumours. Similar findings were reported from a study<sup>32</sup> comparing outcomes after treatment with pembrolizumab in MSI-H and MSS colorectal cancers. PD-L1 expression was detected only in MSI-H tumours, but there was no correlation between PD-L1 levels and PFS or OS.

Another approach is to stimulate immunogenicity within the tumour, for example, by the use of T cell-targeted bispecific antibodies<sup>107</sup>. Bacac and co-workers<sup>108</sup> assessed carcinoembryonic antigen–T cell-bispecific (CEA-TCB) antibody, which binds simultaneously to CD3 expressed

on T cells and CEA, a marker often overexpressed in colorectal cancer. CEA-TCB antibody activity drives T cell proliferation and cytokine release, converting a poorly immunogenic tumour microenvironment into an inflamed one<sup>108</sup>. Thus, CEA-TCB antibody can enhance the effect of immune checkpoint blockade agents, even in MSS tumours. A phase I study<sup>104</sup> assessing the effect of combination treatment with a novel CEA-TCB antibody (RO6958688) and PD-L1 inhibitor (atezolizumab) in patients with heavily pretreated metastatic colorectal cancer showed increased tumour inflammation and radiological evidence of tumour reduction in patients with both MSI-H and MSS colorectal cancer treated with higher-dose combination therapy (Table 1).

Radiotherapy may also stimulate neoantigen generation. Radiation triggers local and systemic immune effects by inducing lethal DNA damage, which increases the visibility of tumour to the host immune environment<sup>109</sup>. The abscopal effect, in which tumour regression occurs at a site distant from the local radiotherapy field, is commonly observed following radiotherapy<sup>110</sup>. Immune cell



infiltration into the tumour environment is crucial for this response and is often lacking in the presence of systemic immunosuppression<sup>111,112</sup>. Case reports have suggested significant clinical benefit in combined immunotherapy and radiotherapy, notably in melanoma<sup>113</sup>. The PACIFIC trial<sup>114</sup>, a phase III randomized trial of the PD-L1 antibody durvalumab as consolidation therapy after radiotherapy in NSCLC, showed significant improvement in PFS with durvalumab compared with placebo (16.8 *versus* 5.6 months). However, the potential for toxicity must be addressed. Combination therapy may generate both tumour-specific and non-tumour-specific antigens, which may induce autoimmune responses<sup>115</sup>. Furthermore, radiotherapy is established in the treatment of rectal cancer<sup>116</sup>, but is not suitable for colonic tumours, which represent 60–70 per cent of the colorectal disease burden<sup>117,118</sup>.

Currently, the only immunotherapeutic agents licensed for use in advanced colorectal cancer with dMMR target the programmed cell death pathway<sup>119</sup>. There is significant potential to identify subgroups of patients who may respond to specific immunotherapeutic agents targeting other immune cell-driven pathways. In mouse solid tumour models, targeting both Tim-3 and PD-1 leads to greater antitumour responses than targeting either pathway separately<sup>120</sup>. Combined Tim-3 and PD-1 blockade is currently in early-phase clinical trials in solid tumours<sup>121</sup>. Bispecific antibodies show promise in boosting the innate

immune response. In addition, the effects of neoantigen clonality in determining the immune microenvironment may provide opportunities to refine the targets employed in cancer vaccination and adoptive cell transfer, potentially making these valuable adjuncts to surgical treatment in colorectal cancer.

### Germline determinants of immunogenicity in colorectal cancer

In contrast to exploration of the role of tumour neoantigens in determining immunogenicity in colorectal cancer, the contribution of inherited, germline differences in immune gene expression to the immune landscape is relatively underexplored. A key development has been the expansion of expression quantitative trait locus (eQTL) studies. eQTLs are single-nucleotide polymorphisms (SNPs) usually found in non-coding regions of the genome, which influence gene expression. They may be *cis* (found in close proximity to the genes they affect) or *trans* (found at distance from the genes they affect, or even on separate chromosomes)<sup>122–124</sup> (Fig. 2).

Repositories of eQTL data, such as the Multiple Tissue Human Expression Resource (MuTHER) project<sup>125</sup> and the Genotype–Tissue Expression Project (GTEx)<sup>126,127</sup>, have facilitated exploration of the influence of eQTLs in determining the expression of phenotypes of interest, including complex diseases and cancer<sup>128–132</sup> (Table 2).

**Fig. 2 Schematic representation of cis- and trans-expression quantitative trait locus effects on targeted genes**

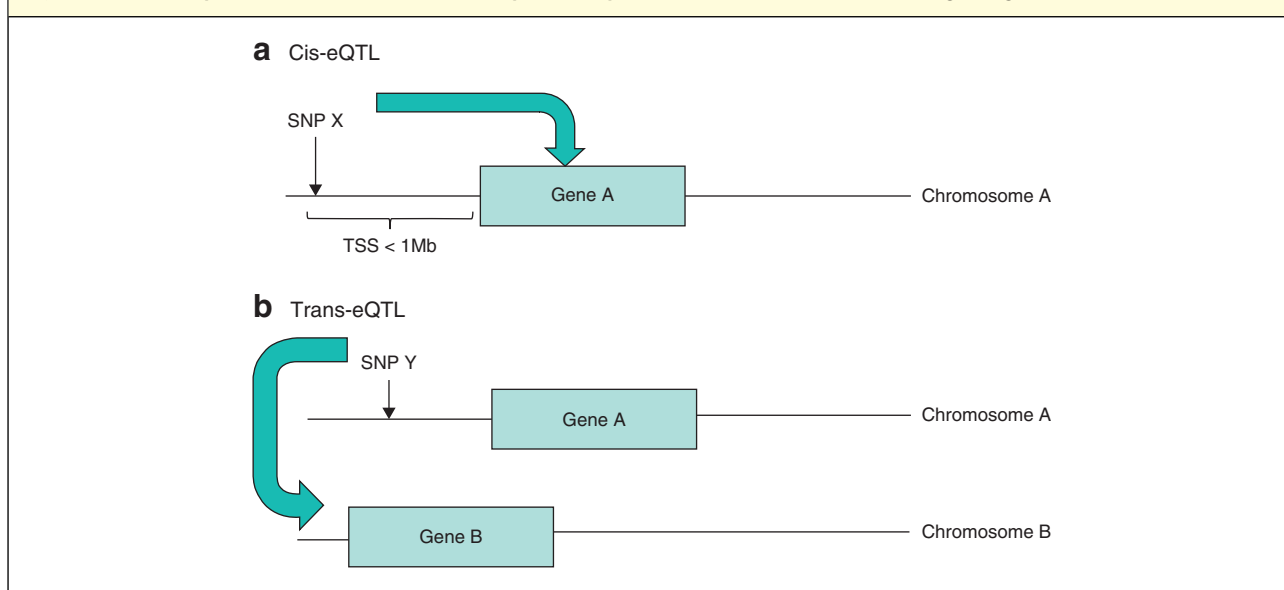

**a** Cis-expression quantitative trait locus (eQTL) single-nucleotide polymorphism (SNP) effect on gene A; **b** trans-eQTL effect on gene B on a different chromosome. TSS, transcription start site.

**Table 2** Large-scale human expression quantitative trait locus repositories

Project name	Data repository	eQTL	Tissue subtypes	Sample size
MuTHER	<a href="http://www.muther.ac.uk/Data.html">http://www.muther.ac.uk/Data.html</a>	Cis	LCL, skin, adipose	856
GTEEx	<a href="https://www.gtportal.org/home/">https://www.gtportal.org/home/</a>	Cis	Multiple	237
Childhood asthma studies <sup>128,129</sup>	<a href="http://csg.sph.umich.edu/liang/imputation/">http://csg.sph.umich.edu/liang/imputation/</a>	Cis and trans	EBVL	2642
International HapMap Project <sup>130</sup>	<a href="https://www.ncbi.nlm.nih.gov/geo/query/acc.cgi?acc=GSE6536">https://www.ncbi.nlm.nih.gov/geo/query/acc.cgi?acc=GSE6536</a>	Cis and trans	LCL	270
Gilad/Pritchard Group	<a href="http://eqtl.uchicago.edu/Home.html">http://eqtl.uchicago.edu/Home.html</a>	Cis and trans	LCL, liver, brain	
Pickrell Lab	<a href="http://gwas-browser.nygenome.org">http://gwas-browser.nygenome.org</a>	Cis and trans	Multiple	Combined sources <sup>131</sup>
Geuvadis Project	<a href="https://www.ebi.ac.uk/Tools/geuvadis-das/">https://www.ebi.ac.uk/Tools/geuvadis-das/</a>	Cis	LCL	465
Blood eQTL <sup>132</sup>	<a href="https://genenetwork.nl/bloodeqtlbrowser/">https://genenetwork.nl/bloodeqtlbrowser/</a>	Cis and trans	Peripheral blood	5311

eQTL, expression quantitative trait locus; MuTHER, Multiple Tissue Human Expression Resource Project; LCL, lymphoblastoid cell lines; GTEEx, Genotype–Tissue Expression Project; EBVL, Epstein–Barr virus-transformed cell lines.

Vogelsang *et al.*<sup>133</sup> used data from the MuTHER project to identify immune gene eQTLs and correlate these with outcomes in cutaneous melanoma. Of the 382 immunomodulatory genes selected, SNP genotyping of the 50 most significant cis-eQTLs in the MuTHER lymphoblastoid cell line database was performed and correlated with outcome. Two SNPs identified were highly correlated with OS, one affecting interleukin 19 expression and the other BATF3 expression. Landmark-Høyvik and colleagues<sup>134</sup> showed that the expression of MHC class I and II genes in breast cancer survivors was associated with SNPs in 100 genes. Comparison with a matched healthy cohort revealed specific associations with genes enriched for immune system processes. Although the predictive value of these eQTLs has not yet been explored, the detection of relevant immune genes in patients with colorectal cancer and interrogation of their biological roles will provide further targets for therapy.

### Gut microbiome in colorectal immunogenicity

Interactions between gut microbiota, the evolution of colorectal cancer and responses to therapy are complex. In animal models, specific microbes associated with colonic inflammation can drive carcinogenesis. *Bacteroides fragilis* rapidly induces colitis and colonic tumours in mice heterozygous for the adenomatous polyposis coli gene, with marked downregulation of effector T cell responses and upregulation of Treg responses<sup>135</sup>. In patients with colorectal cancer, there is a large degree of heterogeneity in gut microbiota composition, with differences between faecal and mucosal samples, and between proximal and distal tumours<sup>136</sup>. However, the gut microbiota differ significantly between patients with colorectal cancer and healthy controls<sup>136</sup>. It is uncertain whether these altered

microbiota are drivers of carcinogenesis rather than passengers, reflecting the immune responses occurring within the colonic mucosa.

Routy and colleagues<sup>137,138</sup> showed that abnormal gut microbiome composition could be responsible for non-response to anti-PD-1 immunotherapy in patients with a range of epithelial cancers, mainly NSCLC and renal cell carcinoma. Systemic antibiotic treatment, which alters the gut microbiome, just before commencing immunotherapy led to worsened PFS and OS than that in a comparable non-treated group. Differences in microbe profiles were noted, with an abundance of *Akkermansia muciphilia* and *Alistipes indistinctus* in responders to immunotherapy. Furthermore, faecal mucosal transplantation (FMT) from responders into germ-free or antibiotic-treated mouse tumour models led to significant antitumour responses, with upregulation of dendritic cell and effector T cell responses. This did not occur with FMT from non-responders<sup>137</sup>. In metastatic melanoma, microbiota in responders to immunotherapy demonstrated an abundance of *Bifidobacterium longum*, *Collinsella aerofaciens* and *Enterococcus faecium*, whereas non-responders had an abundance of *Ruminococcus obeum* and *Roseburia intestinalis*. A germ-free mouse tumour model also demonstrated similar responses to FMT from responders<sup>139</sup>. The translation of these findings into clinical studies, and into patients with colorectal cancer is an exciting potential avenue of interest.

### Overview

Advances in genetics and cancer immunology have improved understanding of the drivers of immunogenicity in cancer and potential mechanisms for treatment, particularly in cancers that are refractory to current therapies. The role of immunotherapy in colorectal cancer in particular is

expanding. Recent guidelines<sup>140,141</sup> mandate testing biopsy or resected specimens from all patients with colorectal cancer for Lynch syndrome. This involves a genomic or immunohistochemical screen for MSI, followed by further *BRAF* mutational and *MLH1* hypermethylation analysis to distinguish Lynch from non-Lynch colorectal cancer. The emphasis is on making the diagnosis of Lynch syndrome to facilitate intensive screening to improve clinical outcomes. However, screening is not universal and guidelines often limit this to patients aged less than 70 years<sup>140,141</sup>. Given the prognostic differences in MSI and MSS colorectal cancer outcomes, and the potential for expansion of the role of immunotherapy in this patient group, this information is critically relevant even in those with sporadic MSI-H colorectal cancer.

For those with MSS colorectal cancer, there are currently no clinically applicable immunogenomic tests to determine the efficacy of immunotherapy. Immunohistochemical markers such as the Immunoscore<sup>®</sup> and data from genome sequencing have shown the clear potential to identify other equally beneficial markers. In addition, adjuvant methods to boost immunogenicity show significant promise. Although many aspects of these therapies are in their infancy, the potential for the development and application of targeted treatments with greater efficacy and reduced toxicity is attractive. It is anticipated that refined and targeted immune therapies will become part of standard treatment regimens in patients with colorectal cancer at all disease stages.

## Acknowledgements

Sources of funding for research and publication: Birmingham Health Partners and Bowel Disease Research Foundation (T.O.S.); Cancer Research UK, Medical Research Council, Wellcome Trust and Illumina (A.D.B.); National Institute for Health Research (NIHR) Global Health Research, Cancer Research UK, Royal College of Surgeons of England and National Cancer Research Institute (D.G.M.); Cancer Research UK, NIHR, Merck Sharp and Dohme and British Lung Foundation (G.M.).

*Disclosure:* The authors declare no conflict of interest.

## References

- 1 Taube JM, Galon J, Sholl LM, Rodig SJ, Cottrell TR, Giraldo NA *et al.* Implications of the tumor immune microenvironment for staging and therapeutics. *Mod Pathol* 2018; **31**: 214–234.
- 2 Siska PJ, Rathmell JC. T cell metabolic fitness in antitumor immunity. *Trends Immunol* 2015; **36**: 257–264.
- 3 Valentini AM, Di Pinto F, Cariola F, Guerra V, Giannelli G, Caruso ML *et al.* PD-L1 expression in colorectal cancer defines three subsets of tumor immune microenvironments. *Oncotarget* 2018; **9**: 8584–8596.
- 4 Pardoll DM. The blockade of immune checkpoints in cancer immunotherapy. *Nat Rev Cancer* 2012; **12**: 252–264.
- 5 Sanlorenzo M, Vujic I, Posch C, Dajee A, Yen A, Kim S *et al.* Melanoma immunotherapy. *Cancer Biol Ther* 2014; **15**: 665–674.
- 6 Eggermont AMM, Crittenden M, Wargo J. Combination immunotherapy development in melanoma. *Am Soc Clin Oncol Educ Book* 2018; **38**: 197–207.
- 7 Borghaei H, Paz-Ares L, Horn L, Spigel DR, Steins M, Ready NE *et al.* Nivolumab *versus* docetaxel in advanced nonsquamous non-small-cell lung cancer. *N Engl J Med* 2015; **373**: 1627–1639.
- 8 Horn L, Spigel DR, Vokes EE, Holgado E, Ready N, Steins M *et al.* Nivolumab *versus* docetaxel in previously treated patients with advanced non-small-cell lung cancer: two-year outcomes from two randomized, open-label, phase III trials (CheckMate 017 and CheckMate 057). *J Clin Oncol* 2017; **35**: 3924–3933.
- 9 Overman MJ, McDermott R, Leach JL, Lonardi S, Lenz HJ, Morse MA *et al.* Nivolumab in patients with metastatic DNA mismatch repair-deficient or microsatellite instability-high colorectal cancer (CheckMate 142): an open-label, multicentre, phase 2 study. *Lancet Oncol* 2017; **18**: 1182–1191.
- 10 Carethers JM. Differentiating Lynch-like from Lynch syndrome. *Gastroenterology* 2014; **146**: 602–604.
- 11 Guttmacher AE, Collins FS. Welcome to the genomic era. *N Engl J Med* 2003; **349**: 996–998.
- 12 Kim H, Jen J, Vogelstein B, Hamilton SR. Clinical and pathological characteristics of sporadic colorectal carcinomas with DNA replication errors in microsatellite sequences. *Am J Pathol* 1994; **145**: 148–156.
- 13 Boland CR, Goel A. Microsatellite instability in colorectal cancer. *Gastroenterology* 2010; **138**: 2073–2087.e3.
- 14 Gryfe R, Gallinger S. Microsatellite instability, mismatch repair deficiency, and colorectal cancer. *Surgery* 2001; **130**: 17–20.
- 15 Lengauer C, Kinzler KW, Vogelstein B. Genetic instability in colorectal cancers. *Nature* 1997; **386**: 623–627.
- 16 Cohen R, Buhard O, Cervera P, Hain E, Dumont S, Bardier A *et al.* Clinical and molecular characterisation of hereditary and sporadic metastatic colorectal cancers harbouring microsatellite instability/DNA mismatch repair deficiency. *Eur J Cancer* 2017; **86**: 266–274.
- 17 Sehgal R, Sheahan K, O'Connell PR, Hanly AM, Martin ST, Winter DC. Lynch syndrome: an updated review. *Genes (Basel)* 2014; **5**: 497–507.
- 18 Kane MF, Loda M, Gaida GM, Lipman J, Mishra R, Goldman H *et al.* Methylation of the hMLH1 promoter correlates with lack of expression of hMLH1 in sporadic colon tumors and mismatch repair-defective human tumor cell lines. *Cancer Res* 1997; **57**: 808–811.

- 19 Scaltriti M, Baselga J. The epidermal growth factor receptor pathway: a model for targeted therapy. *Clin Cancer Res* 2006; **12**: 5268–5272.
- 20 Westdorp H, Fennemann FL, Weren RD, Bisseling TM, Ligtenberg MJ, Figdor CG *et al.* Opportunities for immunotherapy in microsatellite instable colorectal cancer. *Cancer Immunol Immunother* 2016; **65**: 1249–1259.
- 21 Rodríguez-Soler M, Pérez-Carbonell L, Guarinos C, Zapater P, Castillejo A, Barberá VM *et al.* Risk of cancer in cases of suspected Lynch syndrome without germline mutation. *Gastroenterology* 2013; **144**: 926–932.e1.
- 22 Umar A, Boland CR, Terdiman JP, Syngal S, de la Chapelle A, Rüschoff J *et al.* Revised Bethesda guidelines for hereditary nonpolyposis colorectal cancer (Lynch syndrome) and microsatellite instability. *J Natl Cancer Inst* 2004; **96**: 261–268.
- 23 Popat S, Hubner R, Houlston RS. Systematic review of microsatellite instability and colorectal cancer prognosis. *J Clin Oncol* 2005; **23**: 609–618.
- 24 Nordholm-Carstensen A, Krarup PM, Morton D, Harling H; Danish Colorectal Cancer Group. Mismatch repair status and synchronous metastases in colorectal cancer: a nationwide cohort study. *Int J Cancer* 2015; **137**: 2139–2148.
- 25 Lochhead P, Kuchiba A, Imamura Y, Liao X, Yamauchi M, Nishihara R *et al.* Microsatellite instability and *BRAF* mutation testing in colorectal cancer prognostication. *J Natl Cancer Inst* 2013; **105**: 1151–1156.
- 26 Timmermann B, Kerick M, Roehr C, Fischer A, Isau M, Boerno ST *et al.* Somatic mutation profiles of MSI and MSS colorectal cancer identified by whole exome next generation sequencing and bioinformatics analysis. *PLoS One* 2010; **5**: e15661.
- 27 Galon J, Costes A, Sanchez-Cabo F, Kirilovsky A, Mlecnik B, Lagorce-Pagès C *et al.* Type, density, and location of immune cells within human colorectal tumors predict clinical outcome. *Science* 2006; **313**: 1960–1964.
- 28 Parkes EE, Walker SM, Taggart LE, McCabe N, Knight LA, Wilkinson R *et al.* Activation of STING-dependent innate immune signaling by S-phase-specific DNA damage in breast cancer. *J Natl Cancer Inst* 2016; **109**.
- 29 Mackenzie KJ, Carroll P, Martin CA, Murina O, Fluteau A, Simpson DJ *et al.* cGAS surveillance of micronuclei links genome instability to innate immunity. *Nature* 2017; **548**: 461–465.
- 30 Zhang Y, Rohde LH, Wu H. Involvement of nucleotide excision and mismatch repair mechanisms in double strand break repair. *Curr Genomics* 2009; **10**: 250–258.
- 31 Llosa NJ, Cruise M, Tam A, Wicks EC, Hechenbleikner EM, Taube JM *et al.* The vigorous immune microenvironment of microsatellite instable colon cancer is balanced by multiple counter-inhibitory checkpoints. *Cancer Discov* 2015; **5**: 43–51.
- 32 Le DT, Uram JN, Wang H, Bartlett BR, Kemberling H, Eyring AD *et al.* PD-1 blockade in tumors with mismatch-repair deficiency. *N Engl J Med* 2015; **372**: 2509–2520.
- 33 Yarchoan M, Hopkins A, Jaffee EM. Tumor mutational burden and response rate to PD-1 inhibition. *N Engl J Med* 2017; **377**: 2500–2501.
- 34 Lal N, Beggs AD, Willcox BE, Middleton GW. An immunogenomic stratification of colorectal cancer: implications for development of targeted immunotherapy. *Oncoimmunology* 2015; **4**: e976052.
- 35 Lal N, White BS, Goussous G, Pickles O, Mason MJ, Beggs AD *et al.* *KRAS* mutation and consensus molecular subtypes 2 and 3 are independently associated with reduced immune infiltration and reactivity in colorectal cancer. *Clin Cancer Res* 2018; **24**: 224–233.
- 36 Smeby J, Sveen A, Merok MA, Danielsen SA, Eilertsen IA, Guren MG *et al.* CMS-dependent prognostic impact of *KRAS* and *BRAFV600E* mutations in primary colorectal cancer. *Ann Oncol* 2018; **29**: 1227–1234.
- 37 Loi S, Dushyanthen S, Beavis PA, Salgado R, Denkert C, Savas P *et al.* RAS/MAPK activation is associated with reduced tumor-infiltrating lymphocytes in triple-negative breast cancer: therapeutic cooperation between MEK and PD-1/PD-L1 immune checkpoint inhibitors. *Clin Cancer Res* 2016; **22**: 1499–1509.
- 38 Nosho K, Baba Y, Tanaka N, Shima K, Hayashi M, Meyerhardt JA *et al.* Tumour-infiltrating T-cell subsets, molecular changes in colorectal cancer, and prognosis: cohort study and literature review. *J Pathol* 2010; **222**: 350–366.
- 39 Mlecnik B, Bindea G, Angell HK, Maby P, Angelova M, Tougeron D *et al.* Integrative analyses of colorectal cancer show immunoscore is a stronger predictor of patient survival than microsatellite instability. *Immunity* 2016; **44**: 698–711.
- 40 Burkholder B, Huang RY, Burgess R, Luo S, Jones VS, Zhang W *et al.* Tumor-induced perturbations of cytokines and immune cell networks. *Biochim Biophys Acta* 2014; **1845**: 182–201.
- 41 Keir ME, Liang SC, Guleria I, Latchman YE, Qipo A, Albacker LA *et al.* Tissue expression of PD-L1 mediates peripheral T cell tolerance. *J Exp Med* 2006; **203**: 883–895.
- 42 Postow MA, Callahan MK, Wolchok JD. Immune checkpoint blockade in cancer therapy. *J Clin Oncol* 2015; **33**: 1974–1982.
- 43 Wachowska M, Muchowicz A, Golab J. Targeting epigenetic processes in photodynamic therapy-induced anticancer immunity. *Front Oncol* 2015; **5**: 176.
- 44 Allison KE, Coomber BL, Bridle BW. Metabolic reprogramming in the tumour microenvironment: a hallmark shared by cancer cells and T lymphocytes. *Immunology* 2017; **152**: 175–184.
- 45 Warburg O, Wind F, Negelein E. The metabolism of tumors in the body. *J Gen Physiol* 1927; **8**: 519–530.
- 46 Cairns RA, Harris IS, Mak TW. Regulation of cancer cell metabolism. *Nat Rev Cancer* 2011; **11**: 85–95.

- 47 Jiang Y, Li Y, Zhu B. T-cell exhaustion in the tumor microenvironment. *Cell Death Dis* 2015; **6**: e1792.
- 48 Zhang Y, Ertl HC. Starved and asphyxiated: how can CD8<sup>+</sup> T cells within a tumor microenvironment prevent tumor progression. *Front Immunol* 2016; **7**: 32.
- 49 OuYang LY, Wu XJ, Ye SB, Zhang RX, Li ZL, Liao W *et al.* Tumor-induced myeloid-derived suppressor cells promote tumor progression through oxidative metabolism in human colorectal cancer. *J Transl Med* 2015; **13**: 47.
- 50 Xu B, Yuan L, Gao Q, Yuan P, Zhao P, Yuan H *et al.* Circulating and tumor-infiltrating Tim-3 in patients with colorectal cancer. *Oncotarget* 2015; **6**: 20592–20603.
- 51 Zhou E, Huang Q, Wang J, Fang C, Yang L, Zhu M *et al.* Up-regulation of Tim-3 is associated with poor prognosis of patients with colon cancer. *Int J Clin Exp Pathol* 2015; **8**: 8018–8027.
- 52 Zheng X, Song X, Shao Y, Xu B, Hu W, Zhou Q *et al.* Prognostic role of tumor-infiltrating lymphocytes in esophagus cancer: a meta-analysis. *Cell Physiol Biochem* 2018; **45**: 720–732.
- 53 Pagès F, Kirilovsky A, Mlecnik B, Asslaber M, Tosolini M, Bindea G *et al.* *In situ* cytotoxic and memory T cells predict outcome in patients with early-stage colorectal cancer. *J Clin Oncol* 2009; **27**: 5944–5951.
- 54 Galon J, Pagès F, Marincola FM, Thurin M, Trinchieri G, Fox BA *et al.* The immune score as a new possible approach for the classification of cancer. *J Transl Med* 2012; **10**: 1.
- 55 Galon J, Mlecnik B, Bindea G, Angell HK, Berger A, Lagorce C *et al.* Towards the introduction of the ‘Immunescore’ in the classification of malignant tumours. *J Pathol* 2014; **232**: 199–209.
- 56 Galon J, Pagès F, Marincola FM, Angell HK, Thurin M, Lugli A *et al.* Cancer classification using the Immunescore: a worldwide task force. *J Transl Med* 2012; **10**: 205.
- 57 Pagès F, Mlecnik B, Marliot F, Bindea G, Ou FS, Bifulco C *et al.* International validation of the consensus Immunescore for the classification of colon cancer: a prognostic and accuracy study. *Lancet* 2018; **391**: 2128–2139.
- 58 Jobin G, Rodriguez-Suarez R, Betito K. Association between natural killer cell activity and colorectal cancer in high-risk subjects undergoing colonoscopy. *Gastroenterology* 2017; **153**: 980–987.
- 59 Trotta AM, Ottaiano A, Romano C, Nasti G, Nappi A, De Divitiis C *et al.* Prospective evaluation of cetuximab-mediated antibody-dependent cell cytotoxicity in metastatic colorectal cancer patients predicts treatment efficacy. *Cancer Immunol Res* 2016; **4**: 366–374.
- 60 Ottaiano A, Napolitano M, Capozzi M, Tafuto S, Avallone A, Scala S. Natural killer cells activity in a metastatic colorectal cancer patient with complete and long lasting response to therapy. *World J Clin Cases* 2017; **5**: 390–396.
- 61 Legitimo A, Consolini R, Failli A, Orsini G, Spisni R. Dendritic cell defects in the colorectal cancer. *Hum Vaccin Immunother* 2014; **10**: 3224–3235.
- 62 Kajihara M, Takakura K, Kanai T, Ito Z, Saito K, Takami S *et al.* Dendritic cell-based cancer immunotherapy for colorectal cancer. *World J Gastroenterol* 2016; **22**: 4275–4286.
- 63 Dierssen JW, de Miranda NF, Ferrone S, van Puijenbroek M, Cornelisse CJ, Fleuren GJ *et al.* HNPCC *versus* sporadic microsatellite-unstable colon cancers follow different routes toward loss of HLA class I expression. *BMC Cancer* 2007; **7**: 33.
- 64 Warabi M, Kitagawa M, Hirokawa K. Loss of MHC class II expression is associated with a decrease of tumor-infiltrating T cells and an increase of metastatic potential of colorectal cancer: immunohistological and histopathological analyses as compared with normal colonic mucosa and adenomas. *Pathol Res Pract* 2000; **196**: 807–815.
- 65 Johnson DB, Estrada MV, Salgado R, Sanchez V, Doxie DB, Opalenik SR *et al.* Melanoma-specific MHC-II expression represents a tumour-autonomous phenotype and predicts response to anti-PD-1/PD-L1 therapy. *Nat Commun* 2016; **7**: 10582.
- 66 Meazza R, Comes A, Orengo AM, Ferrini S, Accolla RS. Tumor rejection by gene transfer of the MHC class II transactivator in murine mammary adenocarcinoma cells. *Eur J Immunol* 2003; **33**: 1183–1192.
- 67 Mortara L, Castellani P, Meazza R, Tosi G, De Lerma Barbaro A, Procopio FA *et al.* CIITA-induced MHC class II expression in mammary adenocarcinoma leads to a Th1 polarization of the tumor microenvironment, tumor rejection, and specific antitumor memory. *Clin Cancer Res* 2006; **12**: 3435–3443.
- 68 Guinney J, Dienstmann R, Wang X, de Reyniès A, Schlicker A, Soneson C *et al.* The consensus molecular subtypes of colorectal cancer. *Nat Med* 2015; **21**: 1350–1356.
- 69 Arrington AK, Heinrich EL, Lee W, Duldulao M, Patel S, Sanchez J *et al.* Prognostic and predictive roles of *KRAS* mutation in colorectal cancer. *Int J Mol Sci* 2012; **13**: 12153–12168.
- 70 Liebmann C. Regulation of MAP kinase activity by peptide receptor signalling pathway: paradigms of multiplicity. *Cell Signal* 2001; **13**: 777–785.
- 71 Wieduwilt MJ, Moasser MM. The epidermal growth factor receptor family: biology driving targeted therapeutics. *Cell Mol Life Sci* 2008; **65**: 1566–1584.
- 72 Venderbosch S, Nagtegaal ID, Maughan TS, Smith CG, Cheadle JP, Fisher D *et al.* Mismatch repair status and *BRAF* mutation status in metastatic colorectal cancer patients: a pooled analysis of the CAIRO, CAIRO2, COIN, and FOCUS studies. *Clin Cancer Res* 2014; **20**: 5322–5330.
- 73 Grob JJ, Amonkar MM, Karaszewska B, Schachter J, Dummer R, Mackiewicz A *et al.* Comparison of dabrafenib and trametinib combination therapy with vemurafenib monotherapy on health-related quality of life in patients with unresectable or metastatic cutaneous *BRAF* Val600-mutation-positive melanoma (COMBI-v): results of

- a phase 3, open-label, randomised trial. *Lancet Oncol* 2015; **16**: 1389–1398.
- 74 Dummer R, Ascierto PA, Gogas HJ, Arance A, Mandala M, Liskay G *et al.* Encorafenib plus binimetinib *versus* vemurafenib or encorafenib in patients with *BRAF*-mutant melanoma (COLUMBUS): a multicentre, open-label, randomised phase 3 trial. *Lancet Oncol* 2018; **19**: 603–615.
  - 75 Cremolini C, Loupakis F, Antoniotti C, Lupi C, Sensi E, Lonardi S *et al.* FOLFOXIRI plus bevacizumab *versus* FOLFIRI plus bevacizumab as first-line treatment of patients with metastatic colorectal cancer: updated overall survival and molecular subgroup analyses of the open-label, phase 3 TRIBE study. *Lancet Oncol* 2015; **16**: 1306–1315.
  - 76 Wan PT, Garnett MJ, Roe SM, Lee S, Niculescu-Duvaz D, Good VM *et al.*; Cancer Genome Project. Mechanism of activation of the RAF-ERK signaling pathway by oncogenic mutations of *B-RAF*. *Cell* 2004; **116**: 855–867.
  - 77 Boussemaert L, Girault I, Malka-Mahieu H, Mateus C, Routier E, Rubington M *et al.* Secondary tumors arising in patients undergoing *BRAF* inhibitor therapy exhibit increased *BRAF*–*CRAF* heterodimerization. *Cancer Res* 2016; **76**: 1476–1484.
  - 78 Chapman PB, Hauschild A, Robert C, Haanen JB, Ascierto P, Larkin J *et al.*; BRIM-3 Study Group. Improved survival with vemurafenib in melanoma with *BRAF* V600E mutation. *N Engl J Med* 2011; **364**: 2507–2516.
  - 79 Vogelstein B, Papadopoulos N, Velculescu VE, Zhou S, Diaz LA Jr, Kinzler KW. Cancer genome landscapes. *Science* 2013; **339**: 1546–1558.
  - 80 McGranahan N, Furness AJ, Rosenthal R, Ramskov S, Lyngaa R, Saini SK *et al.* Clonal neoantigens elicit T cell immunoreactivity and sensitivity to immune checkpoint blockade. *Science* 2016; **351**: 1463–1469.
  - 81 Anagnostou V, Smith KN, Forde PM, Niknafs N, Bhattacharya R, White J *et al.* Evolution of neoantigen landscape during immune checkpoint blockade in non-small cell lung cancer. *Cancer Discov* 2017; **7**: 264–276.
  - 82 Lennerz V, Fatho M, Gentilini C, Frye RA, Lifke A, Ferel D *et al.* The response of autologous T cells to a human melanoma is dominated by mutated neoantigens. *Proc Natl Acad Sci U S A* 2005; **102**: 16 013–16 018.
  - 83 Karasaki T, Nagayama K, Kuwano H, Nitadori JI, Sato M, Anraku M *et al.* Prediction and prioritization of neoantigens: integration of RNA sequencing data with whole-exome sequencing. *Cancer Sci* 2017; **108**: 170–177.
  - 84 Vitiello A, Zanetti M. Neoantigen prediction and the need for validation. *Nat Biotechnol* 2017; **35**: 815–817.
  - 85 Lu YC, Robbins PF. Cancer immunotherapy targeting neoantigens. *Semin Immunol* 2016; **28**: 22–27.
  - 86 McLaren W, Gil L, Hunt SE, Riat HS, Ritchie GR, Thormann A *et al.* The ensemble variant effect predictor. *Genome Biol* 2016; **17**: 122.
  - 87 Andreatta M, Nielsen M. Gapped sequence alignment using artificial neural networks: application to the MHC class I system. *Bioinformatics* 2016; **32**: 511–517.
  - 88 Nielsen M, Lundegaard C, Warming P, Lauemøller SL, Lamberth K, Buus S *et al.* Reliable prediction of T-cell epitopes using neural networks with novel sequence representations. *Protein Sci* 2003; **12**: 1007–1017.
  - 89 Jensen KK, Andreatta M, Marcatili P, Buus S, Greenbaum JA, Yan Z *et al.* Improved methods for predicting peptide binding affinity to MHC class II molecules. *Immunology* 2018; **154**: 394–406.
  - 90 Schumacher TN, Schreiber RD. Neoantigens in cancer immunotherapy. *Science* 2015; **348**: 69–74.
  - 91 Rosenberg SA, Restifo NP. Adoptive cell transfer as personalized immunotherapy for human cancer. *Science* 2015; **348**: 62–68.
  - 92 Carreno BM, Magrini V, Becker-Hapak M, Kaabinejadian S, Hundal J, Petti AA *et al.* Cancer immunotherapy. A dendritic cell vaccine increases the breadth and diversity of melanoma neoantigen-specific T cells. *Science* 2015; **348**: 803–808.
  - 93 Lee HJ, Kim YA, Sim CK, Heo SH, Song IH, Park HS *et al.* Expansion of tumor-infiltrating lymphocytes and their potential for application as adoptive cell transfer therapy in human breast cancer. *Oncotarget* 2017; **8**: 113 345–113 359.
  - 94 Topalian SL, Hodi FS, Brahmer JR, Gettinger SN, Smith DC, McDermott DF *et al.* Safety, activity, and immune correlates of anti-PD-1 antibody in cancer. *N Engl J Med* 2012; **366**: 2443–2454.
  - 95 Brahmer JR, Tykodi SS, Chow LQ, Hwu WJ, Topalian SL, Hwu P *et al.* Safety and activity of anti-PD-L1 antibody in patients with advanced cancer. *N Engl J Med* 2012; **366**: 2455–2465.
  - 96 Le DT, Durham JN, Smith KN, Wang H, Bartlett BR, Aulakh LK *et al.* Mismatch repair deficiency predicts response of solid tumors to PD-1 blockade. *Science* 2017; **357**: 409–413.
  - 97 U.S. Food & Drug Administration. *FDA Grants Accelerated Approval to Pembrolizumab for First Tissue/Site Agnostic Indication*; 2017. <https://www.fda.gov/Drugs/InformationOnDrugs/ApprovedDrugs/ucm560040.htm> [accessed 26 February 2019].
  - 98 Overman MJ, Lonardi S, Wong KYM, Lenz HJ, Gelsomino F, Aglietta M *et al.* Durable clinical benefit with nivolumab plus ipilimumab in DNA mismatch repair-deficient/microsatellite instability-high metastatic colorectal cancer. *J Clin Oncol* 2018; **36**: 773–779.
  - 99 Mettu NB, Niedzwiecki D, Boland PM, Fakih M, Arrowood C, Bolch E *et al.* BACCI: a phase II randomized, double-blind, placebo-controlled study of capecitabine bevacizumab plus atezolizumab *versus* capecitabine bevacizumab plus placebo in patients with refractory metastatic colorectal cancer. *J Clin Oncol* 2018; **36**(4\_suppl): TPS873–TPS873.
  - 100 ClinicalTrials.gov. *A Study to Investigate Efficacy and Safety of Cobimetinib Plus Atezolizumab and Atezolizumab Monotherapy*

- versus Regorafenib in Participants with Metastatic Colorectal Adenocarcinoma (COTEZO IMblaze370)*; 2016. <https://clinicaltrials.gov/ct2/show/NCT02788279> [accessed 26 February 2019].
- 101 Diaz LA, Le DT, Yoshino T, Andre T, Bendell JC, Koshiji M *et al.* KEYNOTE-177: randomized phase III study of pembrolizumab *versus* investigator-choice chemotherapy for mismatch repair-deficient or microsatellite instability-high metastatic colorectal carcinoma. *J Clin Oncol* 2017; **35**(4\_suppl): TPS815–TPS815.
  - 102 ClinicalTrials.gov. *Avelumab for MSI-H or POLE Mutated Metastatic Colorectal Cancer*; 2017. <https://clinicaltrials.gov/ct2/show/NCT03150706> [accessed 26 February 2019].
  - 103 Sinicrope FA, Ou FS, Shi Q, Nixon AB, Mody K, Lévassieur A *et al.* Randomized trial of FOLFOX alone or combined with atezolizumab as adjuvant therapy for patients with stage III colon cancer and deficient DNA mismatch repair or microsatellite instability (ATOMIC, Alliance A021502). *J Clin Oncol* 2017; **35**(15\_suppl): TPS3630.
  - 104 Tabernero J, Melero I, Ros W, Argiles G, Marabelle A, Rodriguez-Ruiz ME *et al.* Phase Ia and Ib studies of the novel carcinoembryonic antigen (CEA) T-cell bispecific (CEA CD3 TCB) antibody as a single agent and in combination with atezolizumab: preliminary efficacy and safety in patients with metastatic colorectal cancer (mCRC). *J Clin Oncol* 2017; **35**(Suppl): 3002.
  - 105 Eisenhauer EA, Therasse P, Bogaerts J, Schwartz LH, Sargent D, Ford R *et al.* New response evaluation criteria in solid tumours: revised RECIST guideline (version 1.1). *Eur J Cancer* 2009; **45**: 228–247.
  - 106 Shen X, Zhao B. Efficacy of PD-1 or PD-L1 inhibitors and PD-L1 expression status in cancer: meta-analysis. *BMJ* 2018; **362**: k3529.
  - 107 Frankel SR, Baeuerle PA. Targeting T cells to tumor cells using bispecific antibodies. *Curr Opin Chem Biol* 2013; **17**: 385–392.
  - 108 Bacac M, Klein C, Umana P. CEA TCB: a novel head-to-tail 2:1 T cell bispecific antibody for treatment of CEA-positive solid tumors. *Oncimmunology* 2016; **5**: e1203498.
  - 109 Sharabi AB, Nirschl CJ, Kochel CM, Nirschl TR, Francica BJ, Velarde E *et al.* Stereotactic radiation therapy augments antigen-specific PD-1-mediated antitumor immune responses via cross-presentation of tumor antigen. *Cancer Immunol Res* 2015; **3**: 345–355.
  - 110 Liu Y, Dong Y, Kong L, Shi F, Zhu H, Yu J. Abscopal effect of radiotherapy combined with immune checkpoint inhibitors. *J Hematol Oncol* 2018; **11**: 104.
  - 111 Lee Y, Auh SL, Wang Y, Burnette B, Wang Y, Meng Y *et al.* Therapeutic effects of ablative radiation on local tumor require CD8+ T cells: changing strategies for cancer treatment. *Blood* 2009; **114**: 589–595.
  - 112 Crittenden MR, Zebertavage L, Kramer G, Bambina S, Friedman D, Trosch V *et al.* Tumor cure by radiation therapy and checkpoint inhibitors depends on pre-existing immunity. *Sci Rep* 2018; **8**: 7012.
  - 113 Postow MA, Callahan MK, Barker CA, Yamada Y, Yuan J, Kitano S *et al.* Immunologic correlates of the abscopal effect in a patient with melanoma. *N Engl J Med* 2012; **366**: 925–931.
  - 114 Antonia SJ, Villegas A, Daniel D, Vicente D, Murakami S, Hui R *et al.* Durvalumab after chemoradiotherapy in stage III non-small-cell lung cancer. *N Engl J Med* 2017; **377**: 1919–1929.
  - 115 Wang Y, Deng W, Li N, Neri S, Sharma A, Jiang W *et al.* Combining immunotherapy and radiotherapy for cancer treatment: current challenges and future directions. *Front Pharmacol* 2018; **9**: 185.
  - 116 Ma B, Gao P, Wang H, Xu Q, Song Y, Huang X *et al.* What has preoperative radio(chemo)therapy brought to localized rectal cancer patients in terms of perioperative and long-term outcomes over the past decades? A systematic review and meta-analysis based on 41 121 patients. *Int J Cancer* 2017; **141**: 1052–1065.
  - 117 Bray F, Ferlay J, Soerjomataram I, Siegel RL, Torre LA, Jemal A. Global cancer statistics 2018: GLOBOCAN estimates of incidence and mortality worldwide for 36 cancers in 185 countries. *CA Cancer J Clin* 2018; **68**: 394–424.
  - 118 Siegel RL, Miller KD, Jemal A. Cancer statistics, 2018. *CA Cancer J Clin* 2018; **68**: 7–30.
  - 119 Francisco LM, Sage PT, Sharpe AH. The PD-1 pathway in tolerance and autoimmunity. *Immunol Rev* 2010; **236**: 219–242.
  - 120 Sakuishi K, Apetoh L, Sullivan JM, Blazar BR, Kuchroo VK, Anderson AC. Targeting Tim-3 and PD-1 pathways to reverse T cell exhaustion and restore anti-tumor immunity. *J Exp Med* 2010; **207**: 2187–2194.
  - 121 Dempke WCM, Fenchel K, Uciechowski P, Dale SP. Second- and third-generation drugs for immuno-oncology treatment – the more the better? *Eur J Cancer* 2017; **74**: 55–72.
  - 122 Stranger BE, Nica AC, Forrest MS, Dimas A, Bird CP, Beazley C *et al.* Population genomics of human gene expression. *Nat Genet* 2007; **39**: 1217–1224.
  - 123 Schadt EE, Molony C, Chudin E, Hao K, Yang X, Lum PY *et al.* Mapping the genetic architecture of gene expression in human liver. *PLoS Biol* 2008; **6**: e107.
  - 124 Emilsson V, Thorleifsson G, Zhang B, Leonardson AS, Zink F, Zhu J *et al.* Genetics of gene expression and its effect on disease. *Nature* 2008; **452**: 423–428.
  - 125 Nica AC, Parts L, Glass D, Nisbet J, Barrett A, Sekowska M *et al.*; MuTHER Consortium. The architecture of gene regulatory variation across multiple human tissues: the MuTHER study. *PLoS Genet* 2011; **7**: e1002003.
  - 126 Carithers LJ, Moore HM. The Genotype–Tissue Expression (GTEx) Project. *Biopreserv Biobank* 2015; **13**: 307–308.
  - 127 Bahcall OG. Human genetics: GTEx pilot quantifies eQTL variation across tissues and individuals. *Nat Rev Genet* 2015; **16**: 375.

- 128 Dixon AL, Liang L, Moffatt MF, Chen W, Heath S, Wong KC *et al.* A genome-wide association study of global gene expression. *Nat Genet* 2007; **39**: 1202–1207.
- 129 Moffatt MF, Kabesch M, Liang L, Dixon AL, Strachan D, Heath S *et al.* Genetic variants regulating ORMDL3 expression contribute to the risk of childhood asthma. *Nature* 2007; **448**: 470–473.
- 130 International HapMap Consortium. A haplotype map of the human genome. *Nature* 2005; **437**: 1299–1320.
- 131 Pickrell JK. Joint analysis of functional genomic data and genome-wide association studies of 18 human traits. *Am J Hum Genet* 2014; **94**: 559–573.
- 132 Westra HJ, Peters MJ, Esko T, Yaghootkar H, Schurmann C, Kettunen J *et al.* Systematic identification of trans eQTLs as putative drivers of known disease associations. *Nat Genet* 2013; **45**: 1238–1243.
- 133 Vogelsang M, Martinez CN, Rendleman J, Bapodra A, Malecek K, Romanchuk A *et al.* The expression quantitative trait loci in immune pathways and their effect on cutaneous melanoma prognosis. *Clin Cancer Res* 2016; **22**: 3268–3280.
- 134 Landmark-Høyvik H, Dumeaux V, Nebdal D, Lund E, Tost J, Kamatani Y *et al.* Genome-wide association study in breast cancer survivors reveals SNPs associated with gene expression of genes belonging to MHC class I and II. *Genomics* 2013; **102**: 278–287.
- 135 Wu S, Rhee KJ, Albesiano E, Rabizadeh S, Wu X, Yen HR *et al.* A human colonic commensal promotes colon tumorigenesis via activation of T helper type 17 T cell responses. *Nat Med* 2009; **15**: 1016–1022.
- 136 Flemer B, Warren RD, Barrett MP, Cisek K, Das A, Jeffery IB *et al.* The oral microbiota in colorectal cancer is distinctive and predictive. *Gut* 2018; **67**: 1454–1463.
- 137 Routy B, Le Chatelier E, Derosa L, Duong CPM, Alou MT, Daillère R *et al.* Gut microbiome influences efficacy of PD-1-based immunotherapy against epithelial tumors. *Science* 2018; **359**: 91–97.
- 138 Elkrief A, Derosa L, Zitvogel L, Kroemer G, Routy B. The intimate relationship between gut microbiota and cancer immunotherapy. *Gut Microbes* 2018: 1–5.
- 139 Matson V, Fessler J, Bao R, Chongsuwat T, Zha Y, Alegre ML *et al.* The commensal microbiome is associated with anti-PD-1 efficacy in metastatic melanoma patients. *Science* 2018; **359**: 104–108.
- 140 Vasen HF, Blanco I, Aktan-Collan K, Gopie JP, Alonso A, Aretz S *et al.*; Mallorca group. Revised guidelines for the clinical management of Lynch syndrome (HNPCC): recommendations by a group of European experts. *Gut* 2013; **62**: 812–823.
- 141 National Institute for Health and Care Excellence. *Molecular Testing Strategies for Lynch Syndrome in People with Colorectal Cancer*; 2017. <https://www.nice.org.uk/guidance/dg27/chapter/4-Evidence> [accessed 25 February 2019].