

Dual-band filtering antenna using dual-mode patch resonators

Ogbodo, Eugene A; Aly, Mostafa G; Ali, Amira El-Tokhy; Wu, Yun; Wang, Yi

DOI:

[10.1002/mop.31396](https://doi.org/10.1002/mop.31396)

License:

Other (please specify with Rights Statement)

Document Version

Peer reviewed version

Citation for published version (Harvard):

Ogbodo, EA, Aly, MG, Ali, AE-T, Wu, Y & Wang, Y 2018, 'Dual-band filtering antenna using dual-mode patch resonators', *Microwave and Optical Technology Letters*, vol. 60, no. 10, pp. 2564-2569.
<https://doi.org/10.1002/mop.31396>

[Link to publication on Research at Birmingham portal](#)

Publisher Rights Statement:

Checked for eligibility: 05/12/2018

This is the peer reviewed version of the following article: Ogbodo EA, Aly MG, Ali AE, Wu Y, Wang Y. Dual-band filtering antenna using dual-mode patch resonators. *Microw Opt Technol Lett*. 2018;60:2564–2569., which has been published in final form at: <https://doi.org/10.1002/mop.31396>. This article may be used for non-commercial purposes in accordance with Wiley Terms and Conditions for Use of Self-Archived Versions.

General rights

Unless a licence is specified above, all rights (including copyright and moral rights) in this document are retained by the authors and/or the copyright holders. The express permission of the copyright holder must be obtained for any use of this material other than for purposes permitted by law.

- Users may freely distribute the URL that is used to identify this publication.
- Users may download and/or print one copy of the publication from the University of Birmingham research portal for the purpose of private study or non-commercial research.
- User may use extracts from the document in line with the concept of 'fair dealing' under the Copyright, Designs and Patents Act 1988 (?)
- Users may not further distribute the material nor use it for the purposes of commercial gain.

Where a licence is displayed above, please note the terms and conditions of the licence govern your use of this document.

When citing, please reference the published version.

Take down policy

While the University of Birmingham exercises care and attention in making items available there are rare occasions when an item has been uploaded in error or has been deemed to be commercially or otherwise sensitive.

If you believe that this is the case for this document, please contact UBIRA@lists.bham.ac.uk providing details and we will remove access to the work immediately and investigate.



Dual-Band Filtering Antenna Using Dual-mode Patch Resonators

Journal:	<i>Microwave and Optical Technology Letters</i>
Manuscript ID	MOP-18-0194
Wiley - Manuscript type:	Research Article
Date Submitted by the Author:	14-Feb-2018
Complete List of Authors:	Ogbodo, Eugene; University of Greenwich Faculty of Engineering and Science, Engineering Science Wu, Yun; University of Greenwich Faculty of Engineering and Science, Engineering Science Wang, Yi; University of Greenwich Faculty of Engineering and Science, Engineering Science; University of Greenwich
Keywords:	Filter, Antenna, Filtering-antenna, Filter synthesis.

SCHOLARONE™
Manuscripts

Dual-Band Filtering Antenna Using Dual-mode Patch Resonators

Eugene A. Ogbodo*, Mostafa G. Aly, Amira El-Tokhy Ali, Yun Wu, and Yi Wang

*Department of Engineering Science, University of Greenwich
Kent, ME4 4TB, United Kingdom*

*e.a.ogbodo@greenwich.ac.uk

Abstract— This paper proposes the integration of a dual-band bandpass filter and antenna using a filter synthesis method. A dual-mode perturbed patch resonator and a dual-mode patch antenna are used in the implementation. The two patches are placed back-to-back to share a common ground. To increase the degree of freedom in controlling the channel bandwidths and to avoid radiation interference, a slot coupling technique is used to couple both patches. The patch resonator performs the signal splitting and combining function while the patch antenna contributes to the filtering poles and performs the radiating function. Good agreements have been achieved between the measurements of the prototype device and the simulations.

I. INTRODUCTION

Filters and antennas are major components in the front-end of many wireless systems. Conventionally, the designs of these devices use different approaches and often by specialists in their own areas. The input and/or output ports of these devices are assumed to have an interface of 50 Ohm [1-3]. It is also assumed that by maintaining the 50 Ohm interface, the impedance matching would be maintained after cascaded connection. Fig. 1(a) presents the conventional cascade of a filter and an antenna. In practice, the connection between devices introduces losses from interconnection and mismatches, especially when the components are of different bandwidths. A deteriorated performance may be warranted. To overcome the degradation and make the circuit more compact, the integration and co-design of these separate components is a solution [4-8]. This process involves the elimination of the 50 Ohm interface between the antenna and the filter. The integration of these devices reduces the complexity of the system by the elimination of some feeding/matching circuits [9-10]. It is also worth mentioning that the feed networks of the antennas are effectively replaced with filters. Proper integration could also make the antenna function as a resonating pole to the filter. Fig. 1(b) shows such an alternative and integrated filter-antenna system.

Using the filter synthesis method, this paper presents a design of a dual-band bandpass filtering antenna using a dual-mode dual-polarisation antenna and a dual-mode patch resonator. This is different from previous works [11-13]. In [12], a low gain bidirectional dual-band filtering antenna was demonstrated. Two separate patches were used in [11], whereas in [13] the two bands share the same polarisation. Here, a four-pole filtering response is realised with two poles

on each channel. The polarisations at the two channels in this work are orthogonal to each other.

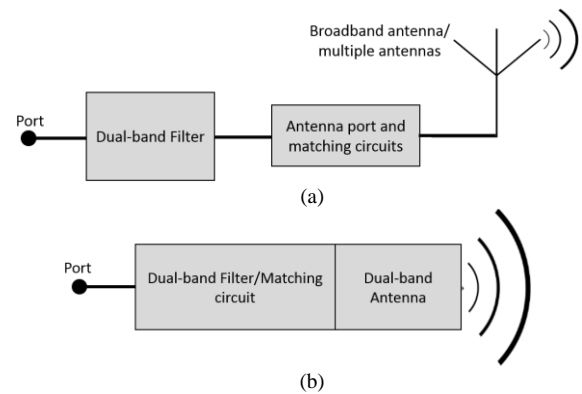

Fig. 1 Filter and antenna in a front-end: (a) Conventional; (b) Proposed

II. DESIGN

A. Layout

Fig. 2 presents the proposed resonator based design in the form of the coupling topology of the dual-band bandpass filtering antenna. The dual mode resonator performs the signal splitting and combining function, designed for 1.8 GHz and 2.1 GHz. Fig. 3(a) shows the front view of the design with a dual-mode patch resonator and the feedline. The perturbed corner creates the two resonant modes at 1.8 GHz and 2.1 GHz respectively [14]. The dual mode antenna performs the radiating functions and contributes to resonating poles of the dual-band filter. The two modes of the patch resonators are coupled with the two modes of the patch antenna respectively to form the dual-band filtering antenna. The coupling is achieved using coupling slots, while the resonator and the antenna are placed in a back-to-back position with a common ground. Fig. 3(b) shows the side view of the device. Two slots in the common ground plane are used to couple the dual-mode resonator to the dual-mode patch antenna. The coupling slot technique is used to realise the required coupling but avoid interference between the antenna and the resonator. Each of the two substrates used is with a relative permittivity of 3.55 and a thickness of 1.524 mm. Fig 3(c) shows the back view with the orthogonal mode patch antenna.

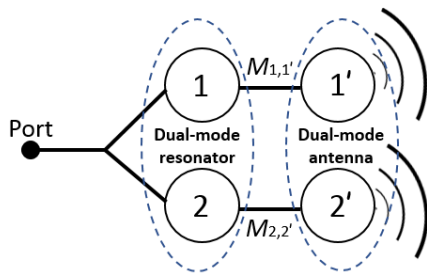

Fig. 2 Dual-band bandpass filtering antenna coupling topology

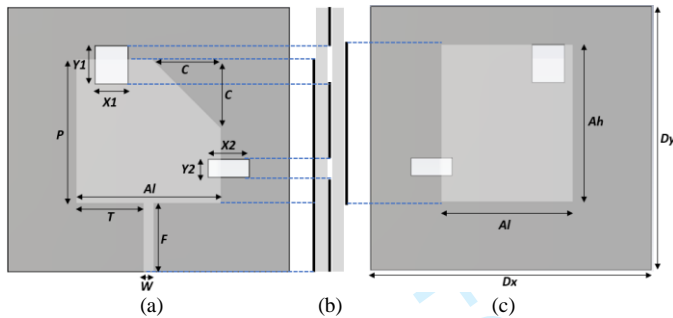

Fig. 3 Dual-band bandpass filtering antenna (a) front view; (b) side view; (c) back view

The stack configuration makes the circuit compact. Also, it provides more degree of freedom to control the mutual couplings between the patch resonator and the patch antenna. CST EM simulation is used for the simulation and optimisation. Table 1 presents the achieved design parameters after optimisation.

Table 1: Design parameters (mm)

P	C	F	W	Ah	Al	T
41.6	20	20	2.9	45.5	38	19.35
$Y1$	$Y2$	$X1$	$X2$	Dx	Dy	
11	5	9.5	12	84.1	76.6	

B. Resonator and antenna configuration

A half-wavelength square patch resonator, resonating at f_0 is perturbed into the dual resonances at f_1 (1.8 GHz) and f_2 (2.1 GHz) by cutting one corner as shown in Fig. 4 [14]. Fig 4 presents the current distribution of the patch resonator at 1.8 and 2.1 GHz respectively. The patch antenna takes a rectangular shape and possesses two orthogonal modes at different frequencies depending on the feeding position used. They generate one horizontal and one vertical linear polarisations. Fig 5 shows the current distribution of the patch antenna at 1.8 and 2.1 GHz respectively.

The filtering characteristics of the filter-antenna are preserved by making the radiation quality factor of the patch antenna equal to the external quality factor at the filter input. This results in the antenna's radiated power (gain response) to be similar to that of the insertion loss response of the filter with minimum insertion loss response in the passband (high

gain) and high rejection in the off-band (low gain). In this design, the antenna is used to produce the second resonant poles of the dual-band filter.

C. Coupling

The coupling topology presented in Fig. 2 contains two coupling paths to the antenna. The filtering response for the low and high passbands are to have 4% fractional bandwidth (FBW) each. This response is designed to meet the two-pole Chebyshev ripple factor of 0.043 dB with a lowpass prototype derived from [15-16] with $g_0 = g_3 = 1.2210$, $g_1 = 0.6648$, and $g_2 = 0.5445$. The g -values are used in obtaining the coupling coefficients M_{ij} and Q_{ex} as well as Q_{rad} used for the physical dimensioning of the resonators. Using the general filter synthesis method, the M_{ij} , Q_{ex} and Q_{rad} were derived from (1) and (2).

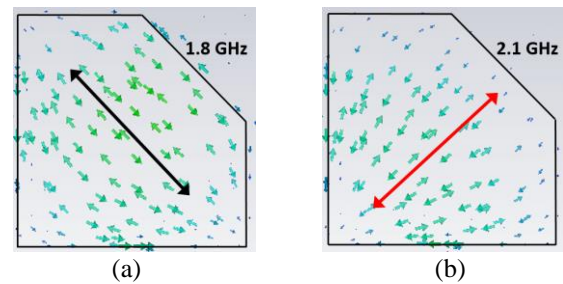

Fig 4 Patch resonator current distribution at (a) 1.8 GHz; (b) 2.1 GHz

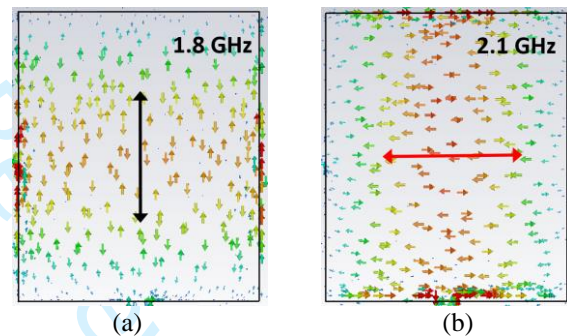

Fig 5 Patch antenna current distribution at (a) 1.8 GHz; (b) 2.1 GHz

$$M_{1,1} = M_{2,2} = \frac{FBW}{\sqrt{g_1 g_2}} = 0.044 \quad (1)$$

$$Q_{ex(L)} = Q_{ex(H)} = Q_{rad(L)} = Q_{rad(H)} = \frac{g_1 g_0}{FBW} = 20.29 \quad (2)$$

where $Q_{ex(L)}$ and $Q_{ex(H)}$ are the external Q -factors from the common port to the low and high channel respectively. $Q_{rad(L)}$ and $Q_{rad(H)}$ are the radiation Q -factors from the antenna to the low and high channel respectively.

The corresponding coupling coefficients between the patch resonator and the patch antenna can be evaluated using (3).

$$M_{ij} = \frac{f_j^2 - f_i^2}{f_j^2 + f_i^2} \quad (3)$$

where f_i and f_j are the two resonant frequencies of the second-order coupled patch resonator and antenna for each channel.

To achieve the Q_{ex} from the common port, a coupled feed line is used as shown in Fig. 6. Port-2 and port-3 were weakly coupled to the patch resonator. The width, length, and tapping distance (T) of the feed line were adjusted to achieve the required Q_{ex} using (4). The Q_{rad} is achieved by weakly coupling the feed lines to the patch antenna and extracting the radiation factor by adjusting the size of the patch and the positions of the feed lines.

$$Q_{ex(L)/(H)} = Q_{rad(L)/(H)} = \frac{f_{1(L)/(H)}}{\Delta f_{1(L)/(H)}} \quad (4)$$

where $f_{1(L)/(H)}$ and $\Delta f_{1(L)/(H)}$ are the centre frequencies and the 3 dB bandwidths of the resonance curves corresponding to the low and high channel. Fig. 6 presents a graph of the typical responses for the Q_{ex} at 1.8 GHz and 2.1 GHz.

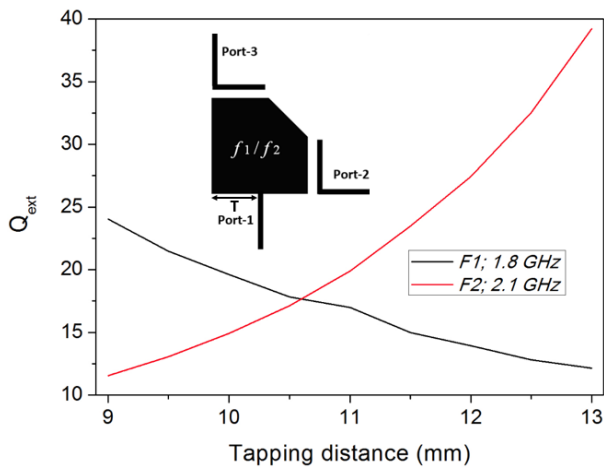

Fig. 6. Typical response of Q_{ex} factor at 1.8 and 2.1 GHz.

III. RESULTS

After extracting the coupling coefficients and $Q_{ex/rad}$, the dual-band bandpass filtering antenna is assembled. Fig. 7(a) compares the simulated S-parameter response of the proposed design with the measured response. It can be seen from the comparison that there is a frequency shift to the right by approximately 20 MHz on the low band and 8 MHz on the high band. This is believed to be a result of fabrication tolerance as well as imperfection in the assembly of the two substrates. Fig. 7(b) presents the simulated gain of the filtering antenna with 4.9 dBi at 1.8 GHz and 5.1 dBi at 2.1 GHz. Fig. 8 and 9 presents the measured farfield radiation patterns for co- and cross-polarisations at 1.8 and 2.1 GHz, respectively.

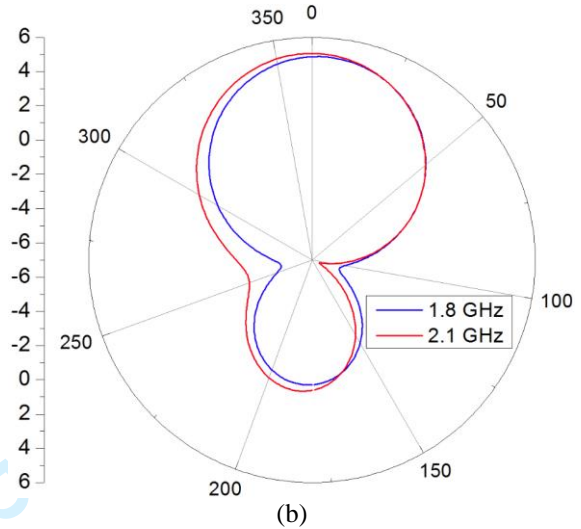
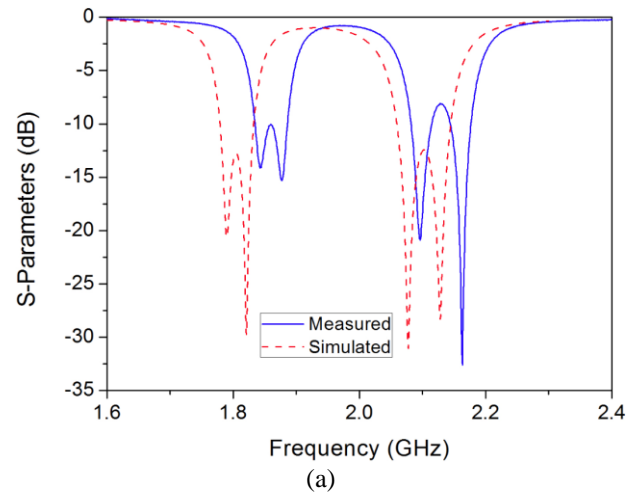

Fig. 7 (a) Simulated S-parameter response in comparison with measurement; (b) Simulated gain at 1.8 GHz and 2.1 GHz

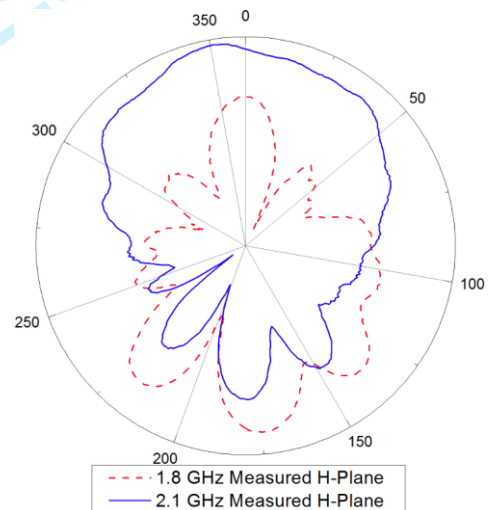

Fig. 8 Measured farfield radiation patterns on the H-plane at 1.8 GHz (Co-pol) and 2.1 GHz (cross-pol).

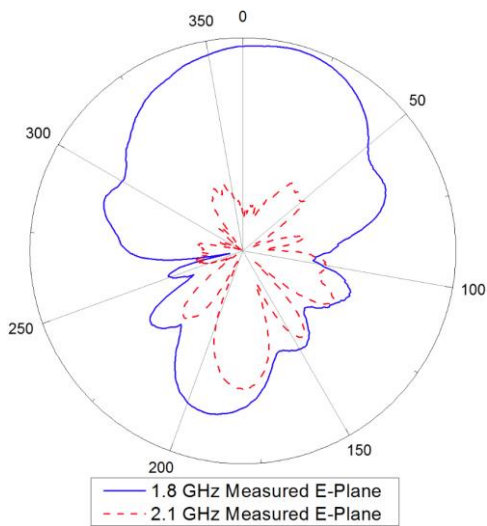

Fig. 9 Measured farfield radiation patterns on the E-plane at 1.8 GHz (cross-pol) and 2.1 GHz (co-pol).

The bandwidths of the two operating bands of the filtering antenna can be tuned by varying the lengths and widths of the coupling slots. By increasing the size of the coupling slots, the coupling strength between the resonator and the antenna can be increased. There by leading to wider bandwidths in the filtering response. If the size of the coupling slots is reduced, the coupling strength will be weakened. Leading to narrower bandwidths in the filtering response. Fig. 10 compares the bandwidths of the filtering response by varying the lengths of the coupling slots at X1 and Y2.

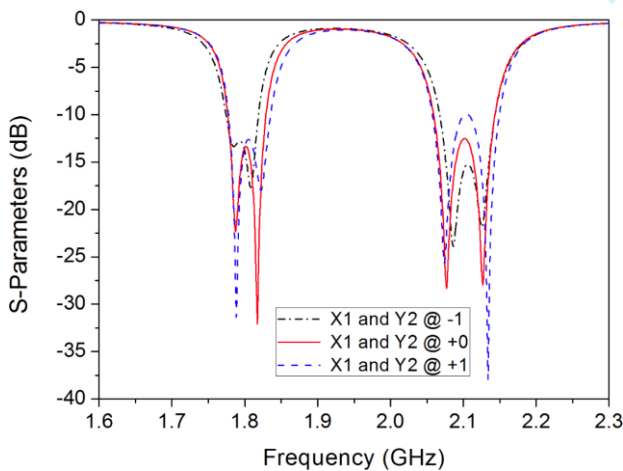

Fig. 10 Bandwidth Variation at different coupling strengths.

IV. CONCLUSIONS

This work has demonstrated a technique of integrating a dual-polarisation antenna with a dual-band bandpass filter. The integration process followed the general filter synthesis procedure; this made the design process simple to implement as the antenna is treated as a resonator. Compared with the conventional cascade designs, the presented design is more compact in size with improved frequency selectivity. The bandwidths of the response can be controlled by adjusting the

coupling slots between the antenna and the resonator. Besides, the patch resonant junction and the coupling slot structure succeeded in easing the implementation of external couplings at the common ports. This design operates orthogonal polarisations in the two bands, making it suitable for application where polarisation diversity is required.

REFERENCES

- [1] E. A. Ogbodo, Y. Wu and Y. Wang, "Dual-Path Dual-Band Filters Based On Patch Resonators," International Workshop on Electromagnetism (iWEM), London, United Kingdom, 2017.
- [2] E. A. Ogbodo, Y. Wu and Y. Wang, "Microstrip diplexers with dual-mode patch resonant junctions," 2016 46th European Microwave Conference (EuMC), London, United Kingdom, 2016, pp. 1155-1158.
- [3] K. Xu, F. Liu, L. Peng, W. S. Zhao, L. Ran and G. Wang, "Multimode and Wideband Printed Loop Antenna Based on Degraded Split-Ring Resonators," IEEE Access, vol. 5, pp. 15561-15570, 2017.
- [4] C. X. Mao, S. Gao, Z. P. Wang, Y. Wang, F. Qin, B. Sanz-Izquierdo, Q. X. Chu, "Integrated filtering-antenna with controllable frequency bandwidth," 2015 9th European Conference on Antennas and Propagation (EuCAP), Lisbon, 2015, pp. 1-4.
- [5] C. Mao, S. Gao and Y. Wang, "Stub-loaded resonator-fed filtering patch antenna with improved bandwidth," 2016 46th European Microwave Conference (EuMC), London, 2016, pp. 317-320.
- [6] C. X. Mao, S. Gao, Y. Wang, F. Qin and Q. X. Chu, "Compact Highly Integrated Planar Duplex Antenna for Wireless Communications," IEEE Transactions on Microwave Theory and Techniques, vol. 64, no. 7, pp. 2006-2013, July 2016.
- [7] A. Eltokhy, Y. Wang, "Integrated Filtering Planar Dipole Antenna Using Edge Coupled Feed", Loughborough Antennas and Propagation Conference, 14-15 November 2016.
- [8] H. Tang, J. X. Chen, H. Chu, G. Q. Zhang, Y. J. Yang and Z. H. Bao, "Integration Design of Filtering Antenna With Load-Insensitive Multilayer Balun Filter," IEEE Transactions on Components, Packaging and Manufacturing Technology, vol. 6, no. 9, pp. 1408-1416, Sept. 2016.
- [9] G. Mansour, M. J. Lancaster, P. S. Hall, P. Gardner and E. Nguocharoenlap, "Design of Filtering Microstrip Antenna Using Filter Synthesis Approach," Progress in Electromagnetics Research (PIER), vol. 145, 2014, pp. 59-67.
- [10] F. Queudet, I. Pele, B. Froppier, Y. Mahe, and S. Toutain, "Integration of Pass-Band Filters in Patch Antennas," in Proc. 32nd Eur. Microw. Conf., 2002, pp. 685-688.
- [11] Y. Zhang, X. Y. Zhang and B. Li, "Dual-band filtering antenna with controllable frequencies and bandwidths," 2016 IEEE 5th Asia-Pacific Conference on Antennas and Propagation (APCAP), Kaohsiung, 2016, pp. 185-186.
- [12] J. H. Yen, N. C. Liu, K. H. Chen and J. H. Tarn, "A compact planar dual-band filtering antenna," 2017 IEEE International Conference on Computational Electromagnetics (ICCEM), Kumamoto, 2017, pp. 367-369.
- [13] C. Mao, S. Gao, Y. Wang, B. Sanz-Izquierdo, Z. Wang, F. Qin, Q. Chu, J. Li, G. Wei, J. Xu, "Dual-Band Patch Antenna with Filtering Performance and Harmonic Suppression", IEEE Trans. Antennas and Propag., vol. 64, no. 9, pp. 4074-4077, Sept. 2016
- [14] E. A. Ogbodo, Y. Wang, and P. B. Rapajic, "Bandpass filters with mixed hairpin and patch resonators," Progress In Electromagnetics Research C, Vol. 59, 101-106, 2015.
- [15] J.-S. Hong "Microstrip Filters for RF/Microwave Applications," John Wiley & Sons, Inc. 2011.
- [16] D. M. Pozar, Microwave Engineering. 3rd ed. New York: Wiley, 2005.