

Optimising resistive charge-division strip detectors for low energy charged-particle spectroscopy

Smith, R.; Bishop, J.; Kokalova Wheldon, Tzanka; Wheldon, Carl; Freer, Martin; Curtis, Neil; Haider, Z.; Parker, D. J.

DOI:

[10.1016/j.nima.2018.05.052](https://doi.org/10.1016/j.nima.2018.05.052)

License:

Creative Commons: Attribution-NonCommercial-NoDerivs (CC BY-NC-ND)

Document Version

Peer reviewed version

Citation for published version (Harvard):

Smith, R, Bishop, J, Kokalova Wheldon, T, Wheldon, C, Freer, M, Curtis, N, Haider, Z & Parker, DJ 2018, 'Optimising resistive charge-division strip detectors for low energy charged-particle spectroscopy', *Nuclear Instruments & Methods in Physics Research. Section A. Accelerators, Spectrometers, Detectors*, vol. 901, pp. 14-20. <https://doi.org/10.1016/j.nima.2018.05.052>

[Link to publication on Research at Birmingham portal](#)

General rights

Unless a licence is specified above, all rights (including copyright and moral rights) in this document are retained by the authors and/or the copyright holders. The express permission of the copyright holder must be obtained for any use of this material other than for purposes permitted by law.

- Users may freely distribute the URL that is used to identify this publication.
- Users may download and/or print one copy of the publication from the University of Birmingham research portal for the purpose of private study or non-commercial research.
- User may use extracts from the document in line with the concept of 'fair dealing' under the Copyright, Designs and Patents Act 1988 (?)
- Users may not further distribute the material nor use it for the purposes of commercial gain.

Where a licence is displayed above, please note the terms and conditions of the licence govern your use of this document.

When citing, please reference the published version.

Take down policy

While the University of Birmingham exercises care and attention in making items available there are rare occasions when an item has been uploaded in error or has been deemed to be commercially or otherwise sensitive.

If you believe that this is the case for this document, please contact UBIRA@lists.bham.ac.uk providing details and we will remove access to the work immediately and investigate.

Accepted Manuscript

Optimizing resistive charge-division strip detectors for low energy charged-particle spectroscopy

R. Smith, J. Bishop, Tz. Kokalova, C. Wheldon, M. Freer, N. Curtis, Z. Haider, D.J. Parker

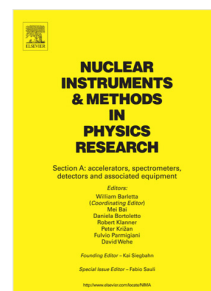

PII: S0168-9002(18)30671-5
DOI: <https://doi.org/10.1016/j.nima.2018.05.052>
Reference: NIMA 60836

To appear in: *Nuclear Inst. and Methods in Physics Research, A*

Received date: 26 April 2018

Accepted date: 24 May 2018

Please cite this article as: R. Smith, J. Bishop, T. Kokalova, C. Wheldon, M. Freer, N. Curtis, Z. Haider, D.J. Parker, Optimizing resistive charge-division strip detectors for low energy charged-particle spectroscopy, *Nuclear Inst. and Methods in Physics Research, A* (2018), <https://doi.org/10.1016/j.nima.2018.05.052>

This is a PDF file of an unedited manuscript that has been accepted for publication. As a service to our customers we are providing this early version of the manuscript. The manuscript will undergo copyediting, typesetting, and review of the resulting proof before it is published in its final form. Please note that during the production process errors may be discovered which could affect the content, and all legal disclaimers that apply to the journal pertain.

Optimizing resistive charge-division strip detectors for low energy charged-particle spectroscopy

R. Smith^{*1}, J. Bishop¹, Tz. Kokalova¹, C. Wheldon¹, M. Freer¹, N. Curtis¹, Z. Haider¹,
D. J. Parker¹

¹*School of Physics and Astronomy, University of Birmingham, Edgbaston, B15 2TT*

Abstract

Two novel approaches to improving the signal-to-background ratio (SBR) for silicon resistive charge-division strip detectors (RSDs), when performing low energy charged-particle spectroscopy, are presented. Firstly, the normally-unutilized rear contact of the detector was used to veto events where the charge collected by this rear face did not match the sum of the charges collected by the strips on the front. Secondly, leading edge discriminator time walk was used to determine complementary information about the hit position along a strip. Using this alongside the position extracted from the charge division allowed clearer identification of true events over background, leading to an improved SBR. These methods were tested by measuring radiation from a triple- α source and then the $^{12}\text{C}(^4\text{He},\alpha)\alpha\alpha\alpha$ breakup reaction at 40 MeV beam energy. The first method was found to improve the SBR by a factor of 4.0(2). The second method gave a SBR improvement of factor of 3.7(4). When both methods are applied together, a total improvement by a factor of 5.7(3) was measured.

Keywords: Charged-particle spectroscopy, semiconductor strip detectors

PACS: 29.40.Gx, 25.55.-e, 29.30.Ep

1. Introduction

Position-sensitive silicon strip detectors (PSDs) are essential for modern nuclear physics experiments involving the measurement of charged particles [1, 2]. In many cases, it is crucial to know both the position (direction) of incidence and the energy of a particle in order to determine the full kinematics of the reaction being measured. Such detectors typically come in two forms, double-sided silicon strip detectors (DSSDs) and resistive charge-division strip detectors (RSDs), which are shown schematically in Figs. 1 and 2, respectively.

Intrinsically, DSSDs and RSDs work in a similar way [3]. The front and rear faces consist of p -type and n -type semiconductor layers respectively, with a reverse bias applied across an electrode layer on each side. The resulting depletion region provides the detection medium and electron-hole pairs, excited by an incident charged particle, are collected by the electrodes on each detector face. The collected charge is proportional to the energy deposited by the particle.

^{*}Current address: Sheffield Hallam University

Email address: Robin.Smith@shu.ac.uk (R. Smith^{*})

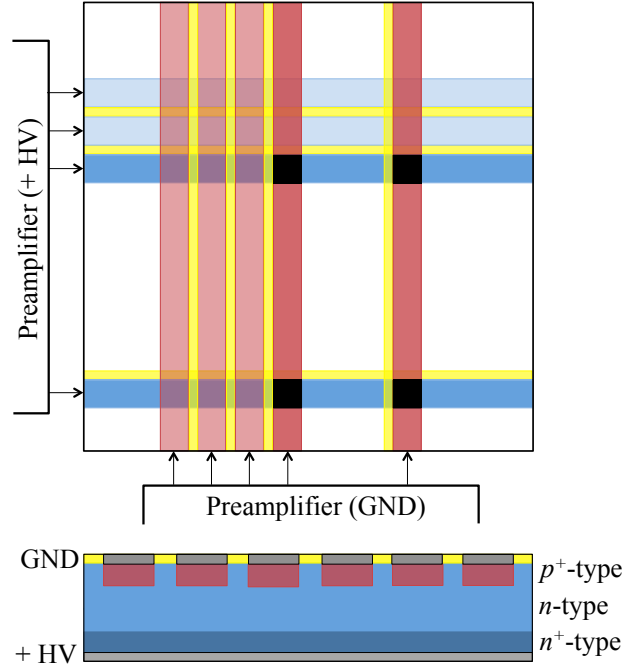

Figure 1: (color online) Schematic diagram of a double-sided silicon strip detector. The upper image shows the face of the detector and the lower image shows the cross section through the detector. When two particles hit the detector, four strips collect charge (two vertical on the front and two horizontal on the rear), which are highlighted in a darker shade. The crossing points in black mark the possible hit points. If the particles are sufficiently close in energy it is not possible to determine which two points are correct.

21 The DSSD electrodes are segmented into horizontal strips (rear) and vertical strips (front),
 22 which are built from low-resistance aluminium and isolated by a thin SiO₂ inter-strip region.
 23 Each strip has a separate readout. This means that by matching the charge collected on a single
 24 front strip with that of a single rear strip (within the detector resolution) the 2D position of a hit
 25 can be determined by their crossing point. The position resolution is therefore defined by the
 26 width of each strip. When multiple particles hit the detector simultaneously, the signals collected
 27 by the front and rear strips are separately ordered in energy. Front and rear strips corresponding
 28 to the same particle will measure a similar energy. These detectors are ideal for high multiplicity
 29 events since they permit large solid angle coverage while minimising pile-up [4].

30 However, problems arise when the energies of the detected particles are very similar. In
 31 this case, energy-matching strips on the front and rear faces can produce a large number of
 32 possible crossing points (scaling with the square of the multiplicity). This can result in the
 33 incorrect assignments of the hit positions for the detected particles. For example, this crossing
 34 point ambiguity remains the largest source of background in determining the breakup branching
 35 ratio of the Hoyle state, which is of interest from a nuclear structure and astrophysical perspective
 36 [5, 6, 7]. Due to the proximity of the Hoyle state to the 3 α decay threshold, the α particles emitted
 37 during the breakup have similar energies.

38 An RSD can provide a platform to more accurately measure the kinematics of these types of

39 reactions, due to the way in which the position of a hit is determined. Like the DSSD, the front
 40 face of an RSD is split into a number of vertical strips, but each carry a $\sim k\Omega$ resistance, and a
 41 signal is taken from each end. The rear face of the RSD is not segmented and is used in biasing
 42 the detector. Due to the strip resistance, the collected signal is linearly attenuated by an amount
 43 depending on the distance from the hit point to the ends of each strip. The position of a hit along
 44 a strip is calculated by combining the signals recorded at each end as [8]

$$f = A \left(\frac{Q_H - Q_L}{Q_H + Q_L} \right). \quad (1)$$

45 The signals collected at the *high* and *low* ends of a strip are labelled as Q_H and Q_L , f is
 46 the fractional position along the strip ($-1 \leq f \leq 1$) and A is a constant to account for the two
 47 $1\text{ k}\Omega$ resistors in series with the strip (see Fig. 2). This method removes the ambiguity regarding
 48 multiple crossing points, which is a feature of DSSDs, and leads to clearer measurements of
 49 coincident particles with similar energies, if they strike separate strips. The charge division
 50 method has been shown to give superior position resolution compared to the DSSD strip width
 51 [9] but this is strongly dependent on the noise environment and the energies of the detected
 52 particles [10]. For high energy particles, a position resolution of 0.1 mm has previously been
 53 obtained. In this study, for low energy particles, a resolution of several mm was observed.

54 However, problems arise when an incident particle has a low energy or if it impacts the
 55 detector at the extreme ends of a strip. For example, consider the case where a particle strikes the
 56 strip shown in Fig. 2 at point 1. Due to the differences in resistance between the two paths taken,
 57 signal Q_H is largest and signal Q_L is highly attenuated. Depending on the energy of the initial
 58 hit, the signal Q_L may have a similar amplitude to the baseline electronic noise of the system.
 59 The same will occur when measuring a low energy particle anywhere along the strip. In order to
 60 record such events, the discriminator thresholds must be lowered towards the level of the noise,
 61 which inevitably leads to a higher chance of triggering on noise and recording background. In the
 62 past, these detectors were most commonly used for higher energy charged-particle spectroscopy,
 63 where typical thresholds of 3 MeV were applied. More modern strip detectors can operate with
 64 lower thresholds [11]. Nonetheless, these still significantly exceed the detection thresholds for
 65 DSSDs which are often set well below 1 MeV. Furthermore, since the active area of the detector
 66 is separated into just 16 channels, these detectors are more susceptible to pile-up. Despite these
 67 pitfalls, for the reasons previously discussed, the use of RSDs is advantageous under certain
 68 circumstances.

69 In this paper we present two methods of improving the performance of RSDs for charged
 70 particle spectroscopy. Both are implemented in the experimental hardware and require varying
 71 degrees of analysis in post-processing software. The first method utilises the energy signal from
 72 the rear contact of the detector. The total charge collected by the rear face of the detector was
 73 measured and compared with the total charge collected by the front face (strips). Secondly, it was
 74 shown that by utilising leading-edge discriminator time walk, it was possible to determine the
 75 position of a detection along a strip. Using this information in conjunction with the position deter-
 76 mined from the charge division permits a reduction of background contributions. Background
 77 reduction using timing is typically implemented using constant fraction discriminators (CFDs),
 78 which give more accurate time measurements. However, we demonstrate that due to the mode
 79 of operation of RSDs, leading edge discriminators can be used instead. Therefore, the presented
 80 methods may be useful in reducing the cost of electronic components in silicon detector arrays.

81 The following section provides a detailed description of each background reduction method

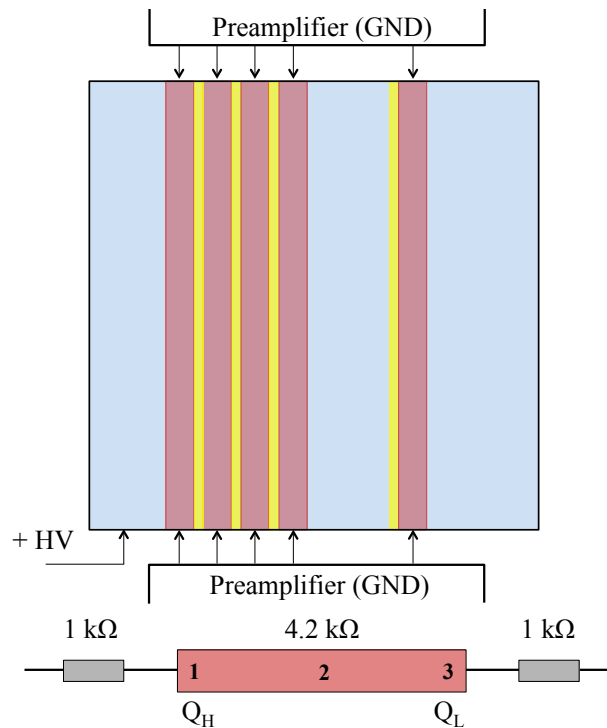

Figure 2: (color online) Schematic diagram of a *Hamamatsu* resistive charge-division strip detector. The upper image shows the face of the detector and the lower image illustrates the charge division mechanism along a single strip. The large rear contact covers the whole detector area and is used to apply the reverse bias. The front strips are held at ground and energy signals are taken from each end. The charges collected at the *high* and *low* ends of the strip are labelled Q_H and Q_L . The hit positions labelled as 1, 2 and 3 are discussed in the text.

82 and their implementation in the experimental hardware. Section 3 then presents the results of
 83 these techniques when applied to measuring radiation from a triple- α source and when measuring
 84 the $^{12}\text{C}(^4\text{He},\alpha)\alpha\alpha\alpha$ breakup reaction.

85 2. Experimental method

86 Under investigation in this study is the *Hamamatsu* 16-strip RSD [Hamamatsu Photonics
 87 Ltd] [12]. This has an active area of $5 \times 5 \text{ cm}^2$ and a thickness of $500 \mu\text{m}$. Although the
 88 *Hamamatsu* detector is no longer in commercial production, the *Micron X1* detector [Micron
 89 Semiconductor Ltd] operates in the same way and is currently implemented in the *TIARA* array,
 90 which has recently been commissioned for use at the Texas A&M Cyclotron Institute [11, 13].
 91 The research outcomes from this paper can, in principle, be applied to any detector which utilises
 92 resistive charge division in one dimension.

93 The two background reduction methods were implemented into the front-end electronics
 94 as shown in Fig. 3. The complete set-up utilised a total of five Mesytec MPR preamplifiers,
 95 seven CAEN N568B spectroscopy amplifiers, five CAEN V895 leading edge discriminators, one
 96 CAEN V775 time-to-digital converter (TDC) and four Silena VME 9418 ADCs. Figure 3 shows
 97 the integration of the *Hamamatsu* RSD into the experimental set-up, which was sufficient to

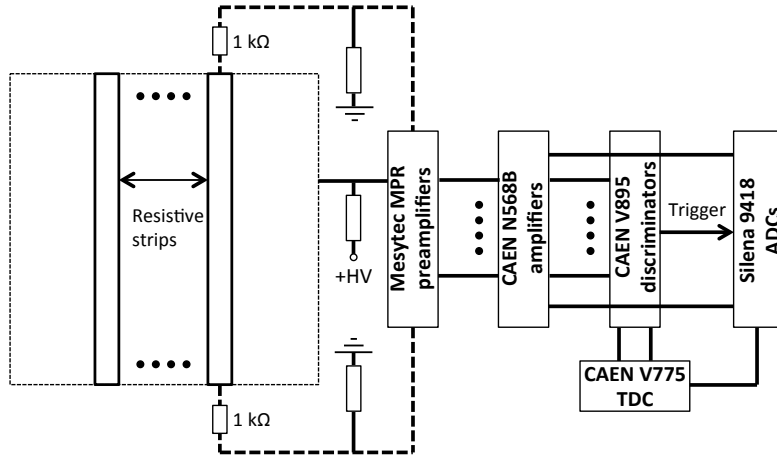

Figure 3: Block diagram of the front-end electronics. The dots signify multiple channels. The triggering logic and the inputs to the TDC are discussed in the text.

98 measure radiation from an α source. In order to measure the $^{12}\text{C}(^4\text{He},\alpha)\alpha\alpha\alpha$ breakup reaction
 99 at 40 MeV bombarding energy, an extra DSSD telescope (64 channels) was introduced. When
 100 measuring this reaction, the ADC trigger required that three or more detector channels fired in
 101 coincidence, across the whole detector array. This condition was implemented across the daisy-
 102 chained V895 discriminators and required no external logic circuit. When measuring radiation
 103 from the triple- α source, a singles trigger was implemented. Micron *WI* detectors of 500 and
 104 $65\ \mu\text{m}$ thickness were used in the DSSD telescope together with a single RSD. Respec-
 105 tively, the telescope and RSD were placed at distances of 9.8 and 8.3 cm from a ^{12}C target and at
 106 centre angles of -90° and $+30^\circ$ with respect to the beam axis.

107 The layout of the detectors inside the vacuum chamber to measure this reaction is shown
 108 in Fig. 4. The α particle from the beam is scattered into the DSSD telescope. The placement
 109 of the detectors maximises the probability that all three α particles resulting from the breakup
 110 of the recoiling ^{12}C (if it is in the near-threshold Hoyle state at 7.65 MeV) hit the single RSD.
 111 This provides complete reaction kinematics. The target was fixed normal to the target plane at
 112 40° to the beam axis. This reduced the energy losses of the α particles before they hit the RSD.
 113 Experimental measurements were performed at the University of Birmingham MC40 cyclotron
 114 facility. The ^4He beam was in a $Q = 2^+$ charge state and data were acquired at a beam current
 115 of 3 nA for three hours. Radiation from the triple- α calibration source was measured for two
 116 hours.

117 The first technique was simple to apply in the hardware; the rear contact of the detector was
 118 biased via a preamplifier, rather than directly from the power supply, in order for the charge col-
 119 lected by this contact to be analysed. From here, this signal, along with those from the strips, was
 120 amplified, discriminated and passed to the ADC before being read-out for analysis in software.
 121 Due to the detection mechanism described in section 1, on average, the same number of electrons
 122 must be collected by the rear contact as the number of holes collected by the front strips. This
 123 condition applies regardless of the hit multiplicity. Provided each detector is correctly calibrated
 124 in energy (using a mixed ^{239}Pu , ^{241}Am and ^{244}Cm source), demanding that the same energy is
 125 collected by the rear contact as the sum of the energies on the front strips, provides a way to
 126 veto events which include triggers from noise. The results of applying this method are given in

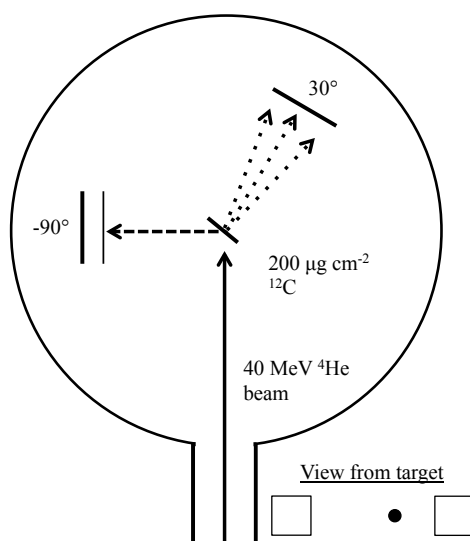

Figure 4: Chamber diagram marking the detector angles with respect to the beam direction. The solid line marks the beam direction, the dashed line marks the path of the scattered beam, and the dotted lines represent the α particles emitted during the breakup of ^{12}C .

127 section 3.1.

128 In order to apply the second background reduction method, both the high and low signals
 129 from every resistive detector strip were amplified and passed to leading edge discriminators.
 130 Each discriminator channel was set to a similar level of around 2.5 MeV. The differential ECL
 131 outputs from the discriminators were then inputted to the TDC as start signals. When measuring
 132 the $^{12}\text{C}(^4\text{He},\alpha)\alpha\alpha\alpha$ breakup reaction, a delayed *or* signal from the rear detector of the separate
 133 DSSD telescope was chosen as the common stop, since it provides an external reference time.
 134 Setting all TDC channels to have a common stop signal meant that the absolute time difference
 135 between the high and low signals, for a given strip, could be calculated. This method was not
 136 applied when measuring α radiation from a source, since each particle only strikes the RSD and
 137 no external reference signal was available for a stop.

138 In previous work, the timing characteristics of two-dimensional resistive detectors were analysed
 139 and a relationship between the hit position and the timing output was identified [14]. This
 140 was qualitatively attributed to a large charge collection time on the resistive detector layer. In
 141 the present study, the TDC was used to measure the time walk arising from the leading edge
 142 discriminators and determine the hit position of a particle along a strip. Time walk corresponds
 143 to the situation shown in Fig. 5, where two pulses with identical shape and time of occurrence,
 144 but different amplitudes, will cross a constant discriminator threshold at different times [15]. If a
 145 particle hits a resistive strip, the pulses recorded at each end of the strip arrive at approximately
 146 the same time. Once integrated by the preamplifier, the pulses possess different amplitudes due
 147 to the resistance of the strip. These pulses are amplified and examined by leading edge discriminators.
 148 Since the resulting time walk depends on the amplitude of each pulse, it can be related
 149 to the charge division and, hence, to the position of a hit along a detector strip. Due to the nearly
 150 Gaussian pulse shapes (using a $1\ \mu\text{s}$ shaping time), the relationship between time walk and hit
 151 position is slightly non-linear and depends on the pulse heights relative to the threshold.

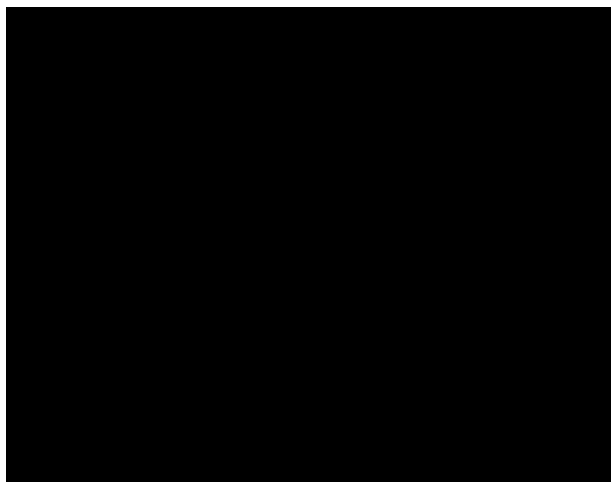

Figure 5: Illustration of the time-walk effect, Δt , of leading edge discrimination.

152 Alone, this method tells us no more about the position of a hit than when using the standard
153 charge division. However, when the two methods are used simultaneously, it is possible to check
154 for consistency between the positions calculated by each. For example, given a particular hit
155 position and, therefore, a particular charge division, there is a defined discriminator time walk
156 which must also be measured (see Fig. 5). If the discriminator triggers on the noise, or the high
157 and low signals correspond to particles associated with different events (random coincidences),
158 the time difference between the high and low signals will be uncorrelated. Removing events
159 where the time difference between the pulses is uncorrelated with the charge division was found
160 to improve the overall signal-to-background ratio (SBR) without a notable drop in efficiency.
161 A typical experiment utilising timing information will use CFDs and demand that all measured
162 pulses lie within a narrow time window. This ensures that all signals in an event correspond to
163 the same nuclear reaction (minimising random coincidences) and do not include uncorrelated
164 triggers on the baseline noise. This paper demonstrates that, due to the RSD mechanism, CFDs
165 are not necessary for timing measurements when using these detectors.

166 3. Analysis and results

167 Background reduction was quantified in two ways. When measuring radiation from the α
168 source, it was simple to examine any background contributions to the energy spectrum. Since
169 the spectrum of discrete energies is known, any noise will manifest as a background to the three
170 features, which arise from the α -decay of the source isotopes. The same cannot be said when
171 measuring the breakup of ^{12}C since, for any given event, the measured α particles may possess a
172 range of energies.

173 Instead, the *sum energy* of each event was used to gauge the background contributions.
174 Due to energy conservation, the sum of the energies of the four final state particles from the
175 $^{12}\text{C}(^4\text{He},\alpha)\alpha\alpha\alpha$ reaction minus the breakup Q value (-7.27 MeV) must equal the 40 MeV beam
176 energy, within the experimental resolution. Events which do not meet this condition are identified
177 as background, likely arising from triggers on noise or due to random coincidences with

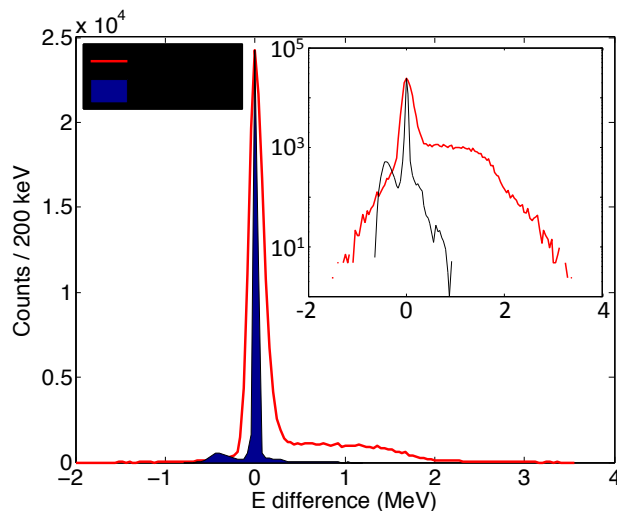

Figure 6: (color online) Difference in energy between the front strips and the rear detector contact. The inset shows the same data on a logarithmic scale. The filled histogram shows the multiplicity-1 α source measurements. The thick (red) line depicts the multiplicity-3 data acquired when measuring the ^{12}C breakup reaction. Most events are centred around an energy difference of zero (within the experimental energy resolution). See text for details.

178 particles associated with separate events. Particles striking particularly close to the inter-strip
 179 region will cause some charge sharing between the strips, and these events may also manifest as
 180 a background to the sum energy peak. The area of the sum energy peak when compared with the
 181 background was used to calculate the SBR. In the data analysis, only complete kinematics events
 182 are considered; a single α particle hit in the DSSD telescope was demanded in coincidence with
 183 three strips on the RSD.

184 This particular breakup reaction and detector arrangement was chosen because of its unam-
 185 biguous kinematic signature. Contaminant reactions $^{12}\text{C}(^4\text{He}, ^8\text{Be})^8\text{Be}$ and $^{12}\text{C}(^4\text{He}, ^{16}\text{O}^*)$ have
 186 the same 4α final state but most often result in a different particle distribution across the detector
 187 array to that shown in Fig. 4. These reactions have the same -7.27 MeV breakup Q value and so
 188 are distinguishable from noise in the sum energy spectrum. The large 90° angle of the telescope
 189 detectors minimises the contributions of direct beam scattering into the telescope causing false
 190 coincidences.

191 3.1. Front and rear contact energy matching

192 Figure 6 shows the difference between the total energy collected by the front strips minus the
 193 energy collected by the rear contact, plotted as a histogram for all events. The shaded histogram
 194 depicts the data acquired when measuring the α source (43973 events). The thick red line shows
 195 the $^{12}\text{C}(^4\text{He}, \alpha)\alpha\alpha\alpha$ reaction data (70656 events). The peaks have been scaled to have the same
 196 amplitude for a visual comparison. The peaks centred on zero in Fig. 6 demonstrate that for the
 197 majority of events, the energies collected by the front strips equals that of the rear contact. The
 198 width of the peaks is due to the detector energy resolution ($\text{FWHM} \approx 120$ keV for the RSD).

199 For both data sets, substantial data reside outside of this main peak and are identified as
 200 contributions from sources of background. A software gate was applied in order to select the
 201 data which reside inside these peaks. Data within 3σ of the peak centroid were taken for further

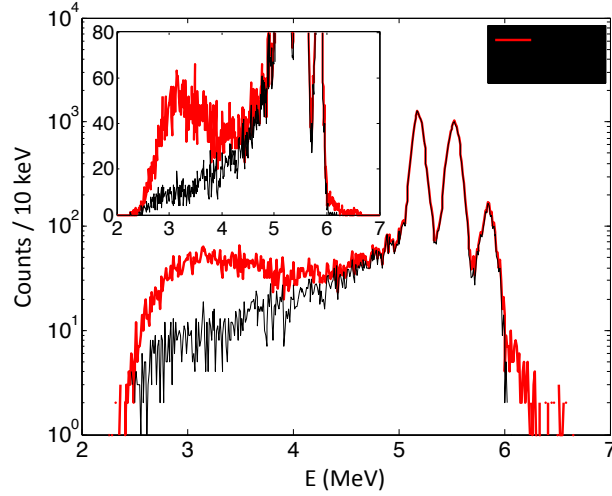

Figure 7: (color online) The measured α -source spectrum before (thick red line) and after (thin black line) the energy matching condition was applied. The main plot has a logarithmic y-axis and the inset shows the same data plotted with a linear y scaling.

202 analysis. Figure 7 shows the measured spectrum of α particle energies before and after this
 203 software gate was applied. The thin, black histogram (after the gate was applied) shows a much
 204 smaller contribution at lower energies, when compared with the thick, red histogram (before the
 205 gate was applied). These events could be due to triggers on the noise, or due to incomplete charge
 206 collection, when a particle strikes the inter-strip region. A total of 12% of events were rejected.

207 Figure 8 shows the sum energy peak for full kinematics breakup events before and after the
 208 software gate was applied to the plot shown in figure 6. The width of these peaks is due to the
 209 detector energy resolution (≈ 60 keV for the DSSDs and ≈ 120 keV for the RSD when measuring a
 210 triple- α source), the energy losses of the particles and the beam in the $200 \mu\text{g}/\text{cm}^2$ target, and the
 211 beam energy spread. This was verified by Monte-Carlo simulations of the reaction and detector
 212 geometry. The Monte-Carlo code is discussed in Refs. [16, 17]. The background beneath the sum
 213 energy peak is reduced after the gate is applied. In both cases, it can be seen that the background
 214 contributions are reduced by around one order of magnitude in some places. Based on the ratio
 215 of the area of the sum energy peak to that of the background area (phenomenologically modelled
 216 as a quartic polynomial to reproduce the correct shape) an improvement of the SBR from 8.8(2)
 217 to 35.2(16) was found. This corresponds to an improvement by a factor of 4.0(2).

218 3.2. Time walk

219 None of the TDC channels were calibrated, however, it was ensured that consistent wire
 220 lengths and delays were used throughout the electronics chain in order for pulses correspond-
 221 ing to a single reaction to enter the TDC at approximately the same time. The maximum TDC
 222 time range of $1.2 \mu\text{s}$ was used. The the charge propagation time from one end of the strip to the
 223 other is about 50 ns, thus, this has a negligible effect here. Each TDC output was recorded to
 224 disk. Figure 9 shows the difference in time between signals recorded at each end of a strip (in
 225 arbitrary TDC units) plotted against the calculated position of a detector hit based on the charge
 226 division. As expected, the time difference due to time walk varies approximately linearly with

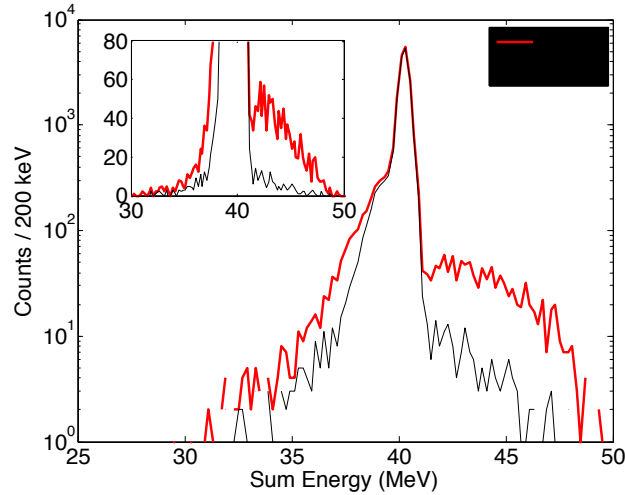

Figure 8: (color online) The measured sum energy spectrum before (thick red line) and after (thin black line) the energy matching condition was applied. The main plot has a logarithmic y-axis scale and the inset has a linear y-axis scale.

227 the detector hit position. Towards the end of each strip, some non-linearity is observed since
 228 this corresponds to a situation where one of the pulses heights is much nearer to the discrimina-
 229 tor threshold and, thus, the time difference is more sensitive to the Gaussian pulse shape. This
 230 behaviour is reproduced when calculations of leading edge triggering on Gaussian pulse shapes
 231 were performed. Along with the data points which lie along the expected diagonal bands, each
 232 plot shows a roughly uniform background of points with no clear correlation between the time
 233 walk and charge division. These points are identified as background contributions.

234
 235 Plots corresponding to different cuts in strip energy are shown in Fig. 9. The TDC time dif-
 236 ference is more sensitive to the position (charge division) for low energy pulses, which manifests
 237 as a steeper gradient. With reference to Fig. 5, due to the Gaussian pulse shape, a small change
 238 in the amplitude of the lower peak will result in a relatively large change in the time walk. This
 239 is because this signals peak closer to the discriminator thresholds. On the other hand, for higher
 240 energy detections, the discriminator threshold is low compared to both the high and low signals,
 241 and a weaker dependence of the time walk on the hit position is observed. This effect manifests
 242 as a shallowing of the gradients of the plots shown in Fig. 9 as the energy is increased.

243 The plots of Fig. 9 were constructed for a number of different energy cuts on the experimental
 244 data, and on a strip-by-strip basis. Assuming a linear relationship between time difference and
 245 position, a linear function was fit to the scatter plots using the `polyfit` least squares fitting
 246 algorithm [Matlab 2012a]. The gradient of the resulting fit, for a single detector strip, as a
 247 function of energy is given by the points with error bars in Fig. 10. The blue line shows the
 248 expected behaviour from calculations of the leading edge discrimination process on Gaussian
 249 pulses. Since the time units given by the TDC are not calibrated, a linear scaling in the vertical
 250 direction was applied in order for the predicted behaviour to best fit the experimental data.

251 Only experimental data points that lay within the diagonal bands shown in Fig. 9 were
 252 selected in the analysis software. In order to achieve this, it was required that the gradient of
 253 each band (assumed to be linear) was known as a function of energy, for each detector strip. To

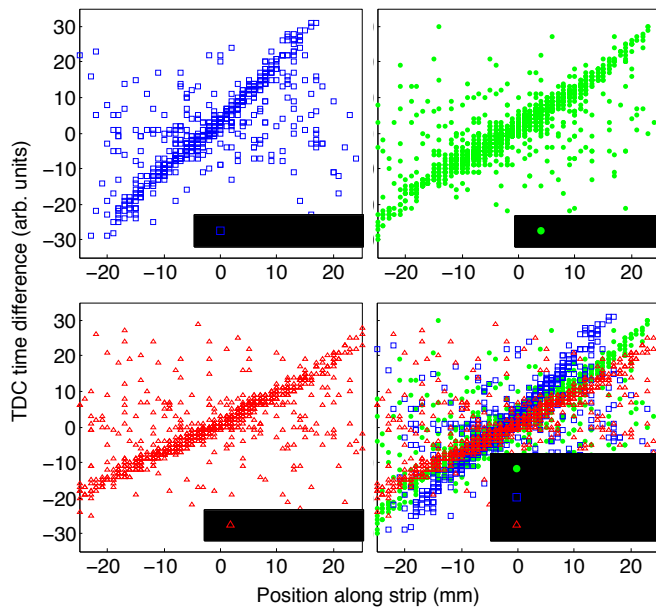

Figure 9: (color online) Position of a hit calculated from the resistive charge division vs the trigger time difference between the pulses at each end of the strip. The data show some non-linearity towards the ends of the strips since this corresponds to the situation where one of the pulse heights is near to the discriminator level. See text for details.

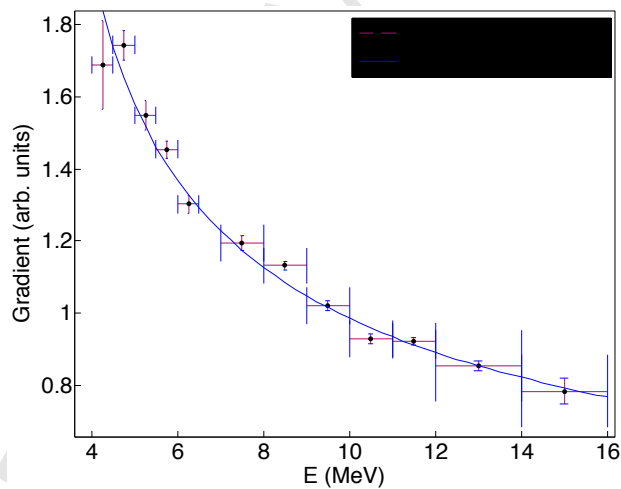

Figure 10: (color online) Gradient of the position vs TDC time difference plots, for different detected energies. The points with error bars show the experimental data. More data exist at lower energies and so these points have smaller energy bin widths. The (blue) line shows the predictions of time walk. Since the time difference is in arbitrary units, the line has been scaled vertically to best fit the experimental data.

254 simplify this process, as an approximation, the data shown in Fig. 10 were phenomenologically
 255 modelled as an exponential of the form

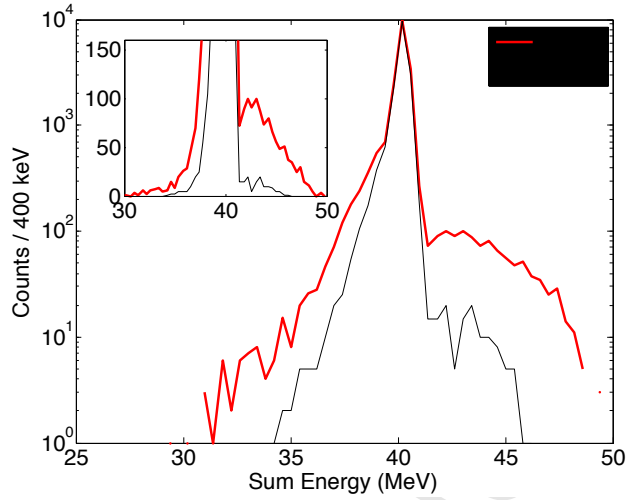

Figure 11: (color online) The measured sum energy spectrum before (thick red line) and after (thin black line) the time walk condition was applied. The main plot has a logarithmic y-axis scale and the inset has a linear y-axis scale.

$$m = \alpha + \beta e^{-\gamma E}, \quad (2)$$

256 where m is the gradient of the band at a particular energy E , and α , β and γ are fit parameters to
 257 be determined. With this relationship known for each detector strip, it was possible to predict,
 258 for a given calculated hit position, what the expected time walk should be. Data that lie within
 259 the typical width of each band (FWHM found to be ≈ 7 TDC units) were selected for further
 260 analysis. Data outside this region were assumed to be events that include triggers by noise.
 261 Figure 11 shows the sum energy spectrum before and after this TDC cut was applied in the
 262 analysis software. Based on the ratio of the area of the sum energy peak to that of the background
 263 area (modelled as a quartic polynomial) an improvement of the SBR from 8.8(2) to 29.2(28) was
 264 found. This leads to an improvement by a factor of 3.7(4). When both background reduction
 265 methods were applied together, a SBR of 50.0(24) was measured, giving a total improvement
 266 factor of 5.7(3).

267 4. Conclusions

268 Two background reduction methods have been developed for resistive charge-division strip
 269 detectors. Despite both providing a similar improvement in the recorded SBR, the authors ad-
 270 vocate the first method of front and rear contact energy matching for practical use at the current
 271 time. It was simple to apply in the experimental hardware and required very little analysis in
 272 post-processing. In contrast, a 32-channel TDC is required in order to apply the second method,
 273 along with substantial analysis in software. Nonetheless, this timing method was proven to be an
 274 effective way of suppressing background contributions, and demonstrates that more costly CFDs
 275 are not required for timing when using RSDs.

276 The authors encourage further investigation into these two methods in the future. Their rel-
 277 ative effectiveness should be evaluated for energies lower than 2.5 MeV. This was prohibited by

278 the set-up employed in this experiment due to the reaction kinematics of the ^{12}C breakup. Al-
279 though both methods show a similar improvement in the SBR for the current measurements, it
280 is possible that this changes as the energies and thresholds are lowered. Further, the presented
281 methods could be applied to the more modern Micron X1 detector since this is currently used in
282 research.

283 5. Acknowledgements

284 The authors gratefully acknowledge all of the staff at the Birmingham MC40 cyclotron for
285 providing the ^4He beam. This work was funded by the United Kingdom Science and Technology
286 Facilities Council (STFC) under grant number ST/L005751/1.

287 6. References

- 288 [1] E. H. M. Heijne, Nucl. Instrum. Methods. A 591 (2008) 6-13.
289 [2] A. Longoni, G. Lutz, A. Schwarz, L. Struder, T. Davinson, A.C. Shotter, E.W. Macdonald, S.V. Springham, P.
290 Jobanputra, A.J. Stephens, S.L. Thomas, Nucl. Instrum. Methods. A 288.1, (1990) 245-249.
291 [3] G. Lutz, Nucl. Instrum. Methods. A 367.1 (1995) 21-33.
292 [4] H. O. U. Fynbo and C. Aa. Diget, Hyperfine Interactions 223:1 (2014) 103.
293 [5] M. Freer et al., Phys. Rev. C 49, R1751 (1994).
294 [6] M. Itoh et al., Phys. Rev. Lett. 113, 102501 (2014).
295 [7] R. Smith et al., Phys. Rev. Lett. 119, 132502 (2017).
296 [8] P. J. Leask, Ph.D. thesis, University of Birmingham (2000).
297 [9] W. N. Catford and R. C. Lemmon and C. N. Timis and M. Labiche and L. Caballero and R. Chapman, AIP
298 Conference Proceedings, 704 (2004) 185-194.
299 [10] A. Robinson, University of Surrey internal report, (2006).
300 [11] M. Labiche, et al. Nucl. Instrum. Methods. A 614.3 (2010) 439-448.
301 [12] Hamamatsu Photonics UK LTD, Welwyn Garden City, Hertfordshire <<http://www.hamamatsu.com>>.
302 [13] Micron Semiconductor LTD, Lancing, Sussex, UK <<http://www.micronsemiconductor.co.uk>>.
303 [14] C.E. Wu, Y.L. Ye, D.X. Jiang, T. Zheng, H. Hua, Z.H. Li, X.Q. Li, Y.C. Ge, G.L. Zhang, D.Y. Pang, J. Wang, J.L.
304 Lou, Nucl. Instrum. Methods. A 555 1-2 (2005) 266-269.
305 [15] G. F. Knoll, Radiation detection and measurement. John Wiley & Sons, (2010) 660.
306 [16] N. Curtis, N. M. Clarke, B. R. Fulton, S. J. Hall, M. J. Leddy, A. S. J. Murphy, J. S. Pople, R. P. Ward, W. N.
307 Catford, G. J. Gyapong, S. M. Singer, S. P. G. Chappell, S. P. Fox, C. D. Jones, D. L. Watson, W. D. M. Rae, and
308 P. M. Simmons, Phys. Rev. C 51, 1554 (1995).
309 [17] N. Curtis, A. S. J. Murphy, N. M. Clarke, M. Freer, B. R. Fulton, S. J. Hall, M. J. Leddy, J. S. Pople, G. Tungate,
310 R. P. Ward, W. N. Catford, G. J. Gyapong, S. M. Singer, S. P. G. Chappell, S. P. Fox, C. D. Jones, D. L. Watson, W.
311 D. M. Rae, P. M. Simmons, and P. H. Regan, Phys. Rev. C 53, 1804 (1996).