

Theoretical analysis on performance enhancement of stand-alone liquid air energy storage from perspective of energy storage and heat transfer

She, Xiaohui; Li, Yongliang; Peng, Xiaodong; Ding, Yulong

DOI:

[10.1016/j.egypro.2017.12.236](https://doi.org/10.1016/j.egypro.2017.12.236)

License:

Creative Commons: Attribution-NonCommercial-NoDerivs (CC BY-NC-ND)

Document Version

Publisher's PDF, also known as Version of record

Citation for published version (Harvard):

She, X, Li, Y, Peng, X & Ding, Y 2018, 'Theoretical analysis on performance enhancement of stand-alone liquid air energy storage from perspective of energy storage and heat transfer', *Energy Procedia*, vol. 142, pp. 3498-3504. <https://doi.org/10.1016/j.egypro.2017.12.236>

[Link to publication on Research at Birmingham portal](#)

Publisher Rights Statement:

Checked for eligibility:15/03/2018

<https://www.sciencedirect.com/science/article/pii/S1876610217359702?via%3Dihub>

<https://doi.org/10.1016/j.egypro.2017.12.236>

General rights

Unless a licence is specified above, all rights (including copyright and moral rights) in this document are retained by the authors and/or the copyright holders. The express permission of the copyright holder must be obtained for any use of this material other than for purposes permitted by law.

- Users may freely distribute the URL that is used to identify this publication.
- Users may download and/or print one copy of the publication from the University of Birmingham research portal for the purpose of private study or non-commercial research.
- User may use extracts from the document in line with the concept of 'fair dealing' under the Copyright, Designs and Patents Act 1988 (?)
- Users may not further distribute the material nor use it for the purposes of commercial gain.

Where a licence is displayed above, please note the terms and conditions of the licence govern your use of this document.

When citing, please reference the published version.

Take down policy

While the University of Birmingham exercises care and attention in making items available there are rare occasions when an item has been uploaded in error or has been deemed to be commercially or otherwise sensitive.

If you believe that this is the case for this document, please contact UBIRA@lists.bham.ac.uk providing details and we will remove access to the work immediately and investigate.



9th International Conference on Applied Energy, ICAE2017, 21-24 August 2017, Cardiff, UK

Theoretical analysis on performance enhancement of stand-alone liquid air energy storage from perspective of energy storage and heat transfer

Xiaohui She^a, Yongliang Li^a, Xiaodong Peng^a, Yulong Ding^{a,*}

^a*School of Chemical Engineering, University of Birmingham, Birmingham B15 2TT, UK*

Abstract

Liquid air energy storage (LAES) is a powerful technology for balancing power supply and demand for a low carbon network. However, its round trip efficiency is relatively lower compared with other large-scale energy storage technologies. In this paper, a stand-alone LAES is studied to provide guidelines for improving its round trip efficiency, from the perspective of energy storage and heat transfer. Storage exergy efficiencies of tanks (η_{st}) and heat transfer thermal efficiencies of heat exchangers (η_{HE}) are considered. Simulation results show that, among the storage tanks, the liquid air tank plays the most important role: when η_{st} increases from 0.7 to 1, η_{RTE} increases dramatically from 0.18 to 0.51; the M-cold tank determines if the stand-alone LAES could work. To improve η_{st} , first, good thermal insulation materials should cover the tanks; second, measures need to be taken to mitigate the mix of energy with different grades in the tanks, such as multi-stage energy storage; thirdly, reducing the number of tanks by looking for a liquid that has large temperature scales from -190 to 20 °C. For the heat exchangers, η_{HE} of HE #2 has the most significant effect on η_{RTE} ; for Cooler or Heater, η_{HE} does not affect η_{RTE} as η_{HE} is above 0.65, which indicates that almost 35% of the stored air compression heat is excess, which could be used for other purposes to improve the round trip efficiency.

© 2017 The Authors. Published by Elsevier Ltd.

Peer-review under responsibility of the scientific committee of the 9th International Conference on Applied Energy.

Keywords: Liquid air energy storage; exergy efficiency; round trip efficiency; air compression

1. Introduction

The concentration of carbon dioxide in the atmosphere has passed the dangerous threshold of 400ppm. Decarbonising the energy sector is a matter of urgency. Renewable energy is a good option and many renewable power

* Corresponding author.

E-mail address: y.ding@bham.ac.uk

plants were installed. The share of renewable energy in global energy consumption was 19% in 2015, and it is possible to achieve a 100% renewable energy future by 2050 [1]. However, renewable energy is intermittent and electric energy storage is needed to balance energy supply and demand. Among the large-scale energy storage technologies, liquid air energy storage (LAES) attracts much attention recently [2-11], which has the potential to overcome the disadvantages of pumped-hydro and compressed air energy storage.

Some researchers focused on the stand-alone LAES [5-8]. Morgan et al. [5, 6] presented analysis and results from the design and testing of novel LAES concept at pilot scale. Fundamental analysis of the LAES cycle was described to determine the theoretical cycle performance and in particular the value of cold recycle. What's more, the material and configuration of the cold thermal store was discussed in particular with reference to scale and measures to mitigate losses due to the irregular and intermittent duty cycle. Sciacovelli et al. [7] proposed a dynamic model for the packed bed cold thermal storage for LAES. It was found that, due to dynamic cycling charge/discharge, packed beds can bring an undesired 25% increase in the energy expenditure needed to liquefy air. Guizzi et al. [8] presented a thermodynamic analysis of a cryogenic energy storage system, based on air liquefaction and storage in an insulated vessel, aiming to assess the efficiency of such a system and to identify if and how it can achieve an acceptable round-trip efficiency (in the order of 50-60%).

Studies on integration of LAES with other technologies were made [9-11]. Li et al. [9] proposed a novel solution by integrating nuclear power generation with LAES technology to achieve an effective time shift of the electrical power output. Simulation results showed that the round trip efficiency of the LAES was higher than 70%. Antonelli et al. [10] modeled different process schemes for hybrid LAES plants, including the natural gas combustion, organic Rankine cycle, and Brayton cycle. Equivalent round-trip efficiencies, higher than 80%, had been calculated.

As shown above, the current research on LAES is mainly on process optimization or system integration, while seldom research is done from the perspective of energy storage and heat transfer efficiency. Considering that it is unavoidably to dissipate heat or cold to the environment during energy storage in tanks and heat transfer in heat exchangers, but it is still not clear how it affects the system round trip efficiency. In this paper, sensitivity studies of the round trip efficiency of LAES on energy storage and heat transfer efficiencies are made, aiming to provide guidelines for reducing energy losses, and further improving the system efficiency.

2. System description

The stand-alone liquid air energy storage (LAES) is shown in Fig. 1, which is composed of an air charging cycle and an air discharging cycle. During off-peak times, the air charging cycle starts to work: ambient air after purified enters the air compressor and is compressed to high pressure (above critical pressure), where air compression heat is stored in the hot tank; then, the high pressure air is gradually cooled down by the cold energy stored in the cold tanks and the low temperature return air; finally, the high pressure air expands to ambient pressure in the cryo-turbine, part of which is liquefied and stored in the liquid air tank. In peak times, the air discharging cycle starts to work: the liquid air is pumped to high pressure (above critical pressure), and releases cold energy to cold storage media; after that, it is heated by the hot fluid stored in the hot tank, and then enters the air turbine to generate electricity.

3. System performance indexes

In the stand-alone LAES, the round trip efficiency, η_{RTE} , is a key parameter to evaluate the system performance and is defined as the ratio of output power in the air discharging cycle (W_{out}) to input power in the air charging cycle (W_{in}),

$$\eta_{RTE} = \frac{W_{out}}{W_{in}} = \frac{W_{air,tur} - W_{cryo-pump}}{W_{air,com} - W_{cryo-tur}} \quad (1)$$

where, the power generation of air turbine is denoted by $W_{air,tur}$; the power consumption of cryo-pump is $W_{cryo-pump}$; the power consumption of air compressor is denoted by $W_{air,com}$; $W_{cryo-tur}$ is the power generation of cryo-turbine.

During energy storage in tanks, energy grade will decay, which results from two reasons: one is the existence of energy gradients in tanks; the other is the heat dissipation to the environment. Therefore, storage exergy efficiency, η_{st} , is used to evaluate the performance of storage, and is defined as the ratio of output exergy (Ex_{out}) to input exergy (Ex_{in}) of tanks,

$$\eta_{st} = \frac{Ex_{out}}{Ex_{in}} \tag{2}$$

$$Ex = m \cdot [(H - H_{amb}) - T_{amb} \cdot (S - S_{amb})] \tag{3}$$

where, the mass of storage medium in tanks is denoted by m ; H and S are the specific enthalpy and entropy of storage medium, respectively; T_{amb} is the ambient temperature.

During heat transfer in heat exchangers, cold or heat from one fluid cannot be totally transferred to other fluids in general, one part of which will be transferred to environment. Here, heat transfer thermal efficiency, η_{HE} , is used to evaluate the performance of heat transfer,

$$\eta_{HE} = \frac{Q_{out}}{Q_{in}} \tag{4}$$

where, Q_{in} is the cold or heat released by one fluid, and Q_{out} is that received by other fluids.

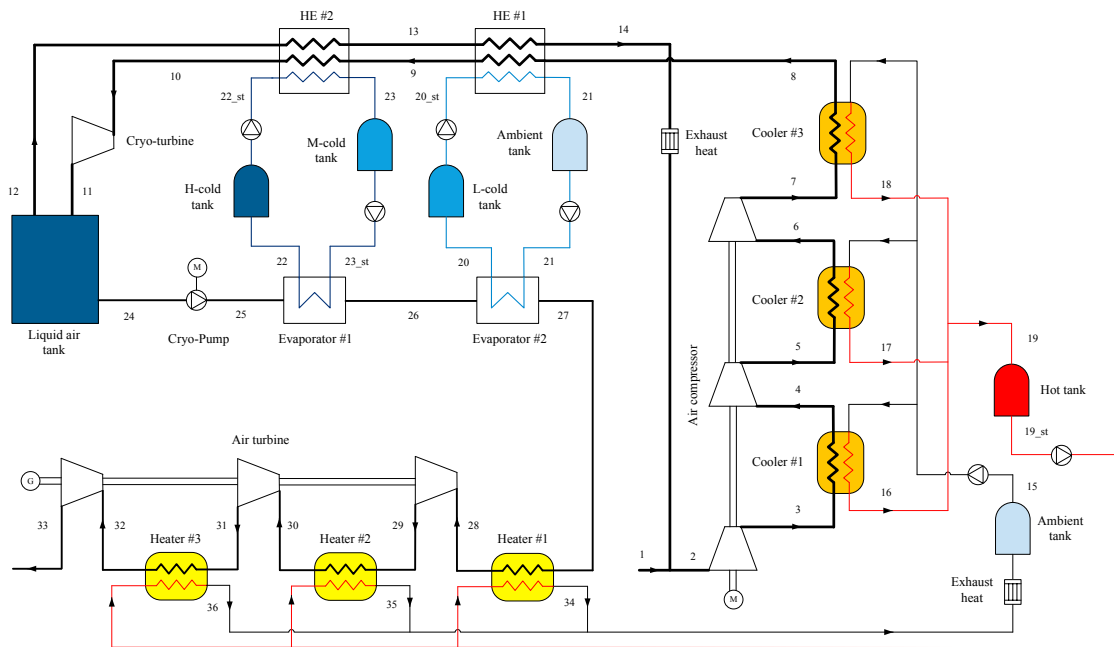

Fig. 1. Schematic diagram of the stand-alone liquid air energy storage.

4. Results and discussion

For the stand-alone LAES, various storage exergy efficiency (η_{st}) and heat transfer thermal efficiency (η_{HE}) are considered to study how the efficiencies affect the round trip efficiency. Working parameters and assumptions are shown in Table 1. Table 2 shows main stream parameters of the stand-alone LAES, where η_{st} and η_{HE} are set to be 1.0.

Table 1. Assumptions and working parameters of the stand-alone liquid air energy storage.

Parameters	Values
Rated output power (MW)	200
Discharging pressure (MPa)	12
Charging time (h)	8
Charging pressure (MPa)	10
Ambient temperature (K)	293
Ambient pressure (kPa)	101
Air compressor efficiency	0.89
Air turbine efficiency	0.9
Cryo-turbine efficiency	0.8
Cryo-pump efficiency	0.7
Pintch point in evaporators (K)	2
Pintch point in other heat exchangers (K)	5

Table 2. Main stream parameters of the stand-alone liquid air energy storage.

Points	Mass flow (kg/s)	Pressure (MPa)	Temperature (K)	Fluid
1	145.6	0.1	293	Air
8	231	10	304.3	Air
9	231	10	223.8	Air
10	231	10	126.1	Air
11	231	0.1	79.5	Air
12	85.4	0.1	81.7	Air
13	85.4	0.1	217.8	Air
14	85.4	0.1	295.4	Air
15	478.2	0.1	293	Dowtherm G
19	478.2	0.1	459.1	Dowtherm G
20	263.3	0.1	207.3	Methanol
21	82.9	0.1	293	Methanol
22	462	0.1	87.7	Propane
23	145.4	0.1	214	Propane
24	462	0.1	78.9	Air
25	462	12	84.7	Air
26	462	12	204.8	Air
27	462	12	287.7	Air
28	462	12	453.7	Air
33	462	0.1	305	Air

4.1 Effect of storage exergy efficiency on the stand-alone LAES

Fig. 2 shows the effect of the storage exergy efficiency (η_{st}) of different tanks on the round trip efficiency (η_{RTE}) of the stand-alone LAES. As shown, η_{RTE} is most sensitive to η_{st} of the liquid air tank: when η_{st} increases from 0.7 to 1, η_{RTE} increases dramatically from 0.18 to 0.51, which indicates that the liquid air tank should be thermally insulated as much as possible to avoid heat dissipation to the environment. η_{st} of the H-cold tank has large effect on η_{RTE} : with the increase of η_{st} , η_{RTE} increases significantly from 0.37 to 0.511. η_{st} of the L-cold tank and Hot tank has less effect

on the round trip efficiency: for the Hot tank, η_{RTE} increases gradually from 0.47 to 0.51; for the L-cold tank, η_{RTE} increases generally from 0.45 to 0.49, keeps almost constant at around 0.49, and then increases gradually to 0.51, which results from the properties of the cold storage medium (methanol). In addition, it should be noted that, for the M-cold tank, the stand-alone LAES cannot work as η_{st} is lower than 0.95, which is because the liquid propane stored in the M-cold tank will become gas.

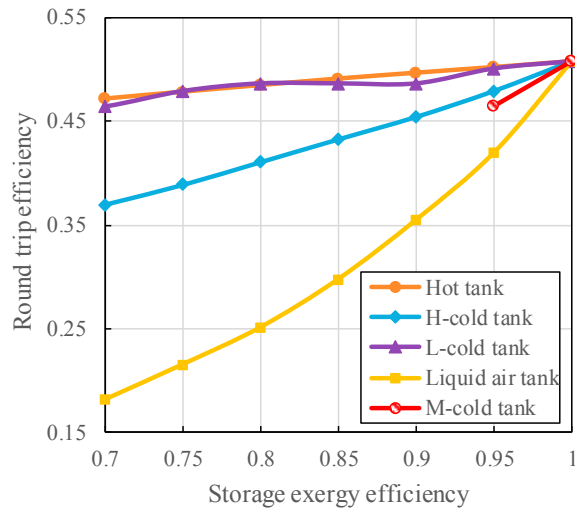

Fig. 2. Effect of storage exergy efficiency on the stand-alone LAES.

4.2. Effect of heat transfer thermal efficiency on the stand-alone LAES

Fig. 3 shows the effect of the heat transfer thermal efficiency (η_{HE}) of key components on the round trip efficiency (η_{RTE}) of the stand-alone LAES. η_{HE} of HE #2 has the most significant effect on η_{RTE} : as η_{HE} increases from 0.6 to 1, η_{RTE} rises dramatically from 0.2 to 0.51, which indicates that thermal insulation of HE #2 should be paid the most attention to. η_{HE} of Evaporator #1 has large effect on η_{RTE} , which increases significantly from 0.33 to 0.51 with the increase of η_{HE} . HE #1 and Evaporator #2 have less influence on η_{RTE} , compared with HE #2 and Evaporator #1. η_{HE} of the Cooler or Heater has no effect on η_{RTE} as it increases above 0.65, which means thermal insulation of the Cooler or Heater is not very important, and it also indicates that the amount of air compression heat stored in the Hot tank exceeds the demand for heating the air before turbines, almost 35% of which is excess and could be used for other purposes to improve the round trip efficiency.

4.3. Potential and methods to improve the round trip efficiency of the stand-alone LAES

Based on the above analyses, it is clear that both the storage exergy efficiency and heat transfer thermal efficiency are crucial for the round trip efficiency of the stand-alone LAES. To improve the storage exergy efficiency, some measures should be taken:

- First, all the storage tanks should be covered with good thermal insulation materials, especially the liquid air tank, H-cold tank and the M-cold tank;
- Second, reducing the number of cold storage tanks, except the liquid air tank, is beneficial to the storage exergy efficiency. One way is to look for a liquid that can match the large temperature scale from -190 to 30 °C, which will be discussed in detail in the following paper;
- Thirdly, multi-stage energy storage, as shown in Fig. 4, would be helpful to reduce the temperature gradients in tanks, and hence improve the storage exergy efficiency.

To improve the heat transfer thermal efficiency, the only way is to make the heat exchangers well insulated. In addition, the above analyses of the Cooler or Heater indicate that almost 35% of air compression heat is excess under

studied conditions. Hence, the use of excess air compression heat will significantly improve the round trip efficiency of the stand-alone LAES:

- One way is to drive an organic Rankine cycle to generate additional electricity in the air discharging cycle;
- Another way is to generate cold energy to help liquefy the gas air in the air charging cycle.

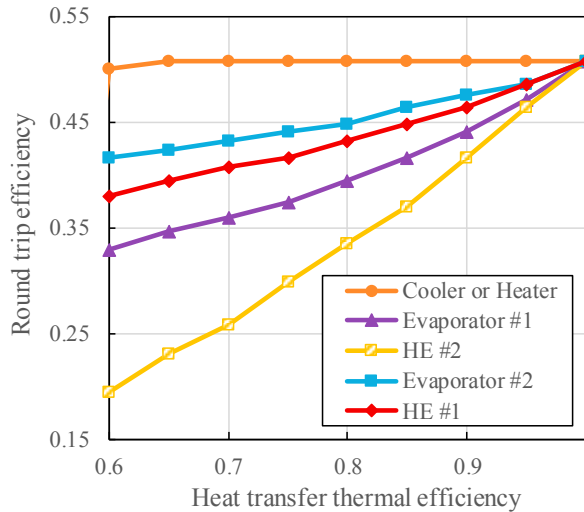

Fig. 3. Effect of heat transfer thermal efficiency on the stand-alone LAES.

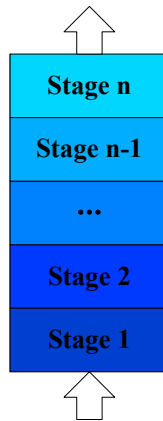

Fig. 4. Multi-stage energy storage to reduce the exergy losses.

5. Conclusions

In this paper, a stand-alone liquid air energy storage system (LAES) is studied to provide guidelines for improving its round trip efficiency, from the perspective of energy storage and heat transfer efficiencies. During energy storage in tanks, it is unavoidably to dissipate heat or cold to the environment, which degrades the stored energy and affects the system round trip efficiency. What’s more, the temperature gradients in tanks, especially the packed beds, will also decrease the energy level. During heat transfer in heat exchangers, part of heat or cold will be transferred to the environment even though the heat exchangers are covered by thermal insulation materials, which reduces the amount of useful heat or cold energy. Storage exergy efficiencies of tanks (η_{st}), including the Liquid air tank, H-cold tank, L-cold tank and the Hot tank, and heat transfer thermal efficiencies of key components (η_{HE}) are considered.

Among the tanks, the liquid air tank plays the most important role, and should be thermally insulated as much as possible: when η_{st} of the liquid air tank increases from 0.7 to 1, η_{RTE} increases dramatically from 0.18 to 0.51. η_{st} of the M-cold tank determines if the stand-alone LAES could work, and should be paid more attention. The L-cold tank and Hot tank have less effect on the round trip efficiency. To improve the η_{st} , on the one hand, good thermal insulation materials should cover the tanks; on the other hand, measures need to be taken to relieve the mix of energy with different grades in tanks, such as the multi-stage energy storage technologies. What's more, reducing the number of tanks will also play key roles.

For the heat exchangers, η_{HE} of HE #2 has the most significant effect on η_{RTE} , and thermal insulation of HE #2 should be made carefully. The importance of thermal insulation of Evaporator #1, HE #2 and Evaporator #2 decreases gradually. For Cooler or Heater, η_{HE} does not affect η_{RTE} as η_{HE} is above 0.65, which indicates that almost 35% of air compression heat stored in the Hot tank is excess under studied conditions. The use of excess air compression heat will be crucial for improving round trip efficiency of the stand-alone LAES: one way is to drive an organic Rankine cycle to generate additional electricity in the air discharging cycle; another way is to generate cold energy to help liquefying the gas air in the air charging cycle.

Acknowledgements

This work was partially supported by EPSRC project of UK (EP/N032888/1).

References

- [1] www.ren21.net Renewables 2017 Global Status Report
- [2] Liquid air in the energy and transport systems. The Centre for Low Carbon Futures; 2013. <http://bit.ly/liquid-air-full-report-2013>.
- [3] Chino K, Araki H. Evaluation of energy storage method using liquid air. Heat Transfer-Asian Research 2000;29:347-57.
- [4] Araki H, Nakabaru M, Chino K. Simulation of heat transfer in the cool storage unit of a liquid-air energy storage system. Heat Transfer-Asian Research 2002;31:284-96.
- [5] Morgan R, Nelmes S, Gibson Emma, Brett G. Liquid air energy storage-analysis and first results from a pilot scale demonstration plant. Appl Energy 2015;137:845-53.
- [6] Morgan R, Nelmes S, Gibson E, Brett G. An analysis of a large-scale liquid air energy storage system. Energy 2015;168(2):1-10.
- [7] Sciacovelli A, Vecchi A, Ding YL. Liquid air energy storage (LAES) with packed bed cold thermal storage-From component to system level performance through dynamic modelling. Applied Energy 2017;190:84-98.
- [8] Guizzi GL, Manno M, Tolomei LM, Vitali RM. Thermodynamic analysis of a liquid air energy storage system. Energy, 2015, 93:1639-1647.
- [9] Li YL, Cao H, Wang S, et al. Load shifting of nuclear power plants using cryogenic energy storage technology. Applied Energy 2014; 113(1):1710-1716.
- [10] Antonelli M, Barsali S, Desideri U, et al. Liquid air energy storage: Potential and challenges of hybrid power plants. Applied Energy 2017; 194:522-529.
- [11] Ameal B, T'Joel C, Kerpel KD, et al. Thermodynamic analysis of energy storage with a liquid air Rankine cycle. Applied Thermal Engineering 2013;52(1):130-140.