

Fuel Cell Technology

Al-Mufachi, Naser; Steinberger-Wilckens, Robert

License:

None: All rights reserved

Document Version

Publisher's PDF, also known as Version of record

Citation for published version (Harvard):

Al-Mufachi, N & Steinberger-Wilckens, R 2017, Fuel Cell Technology. in *The Role of Hydrogen and Fuel Cells in Delivering Energy Security for the UK*. H2FC SUPERGEN Hub White Papers, H2FC SUPERGEN, London, pp. 54-71. <<http://www.h2fcsupergen.com/our-work/whitepapers/>>

[Link to publication on Research at Birmingham portal](#)

General rights

Unless a licence is specified above, all rights (including copyright and moral rights) in this document are retained by the authors and/or the copyright holders. The express permission of the copyright holder must be obtained for any use of this material other than for purposes permitted by law.

- Users may freely distribute the URL that is used to identify this publication.
- Users may download and/or print one copy of the publication from the University of Birmingham research portal for the purpose of private study or non-commercial research.
- User may use extracts from the document in line with the concept of 'fair dealing' under the Copyright, Designs and Patents Act 1988 (?)
- Users may not further distribute the material nor use it for the purposes of commercial gain.

Where a licence is displayed above, please note the terms and conditions of the licence govern your use of this document.

When citing, please reference the published version.

Take down policy

While the University of Birmingham exercises care and attention in making items available there are rare occasions when an item has been uploaded in error or has been deemed to be commercially or otherwise sensitive.

If you believe that this is the case for this document, please contact UBIRA@lists.bham.ac.uk providing details and we will remove access to the work immediately and investigate.

CHAPTER 4

FUEL CELL

TECHNOLOGY

Naser Al-Mufachi and Robert Steinberger-Wilckens –
University of Birmingham

4.1 FUEL CELL BACKGROUND AND HISTORY

Welsh scientist and barrister, Sir William Robert Grove (1811–1896), was credited for the development of the first ever hydrogen fuel cell [91]. During his early years, he studied chemistry at Oxford and practiced patent law. In 1838, Grove was renowned for developing a modified version of a wet-cell battery. Grove deduced that if water could be split into hydrogen and oxygen molecules using electricity then the reverse reaction of combining hydrogen and oxygen molecules would generate electricity. From this hypothesis, Grove constructed a device capable of combining hydrogen and oxygen molecules to produce electricity. This gas battery prototype became known as the fuel cell.

Ludwig Mond (1839–1909) alongside his PhD student and assistant Carl Langer performed experiments with a hydrogen fuel cell which produced 6 A per ft² at 0.73 V [92]. Mond and Langer discovered several issues when using liquid electrolytes. Mond was quoted as saying “we have only succeeded by using an electrolyte in a quasi-solid form soaked up by a porous non-conducting material, in a similar way as has been done in the so-called dry piles and batteries.” Mond made use of an earthenware plate that was saturated with dilute sulphuric acid.

The founder of the field of physical chemistry, Friedrich Wilhelm Ostwald (1853–1932), determined the relationship between the different fuel cell components empirically, which includes the electrodes, electrolyte, oxidising and reducing agent, anions and cations. An electrode is a material that can conduct electricity, an electrolyte is a medium capable of conducting ions; an oxidising agent is an element/compound that accepts electrons from other species in a reaction, a reducing agent is an element/compound that loses electrons to other species in a reaction; anions are negatively charged ions, and cations are positively charged ions. It was the works by Ostwald that helped spearhead and inspire future research into fuel cells research [93]. Throughout the first half of the twentieth century, Emil Baur (1873–1944) conducted extensive research into the area of high temperature fuel cells using a molten silver electrolyte with the aid of his students at Braunschweig, Germany, and Zürich, Switzerland.

Francis Thomas Bacon (1904–1992) pioneered research into high pressure fuel cells. Bacon successfully developed a fuel cell that incorporated nickel gauze electrodes and operated at pressures as high as 200 bar. Bacon’s research continued throughout World War II as he attempted to design and manufacture a fuel cell for use in the Royal Navy submarines. In 1958, Bacon went on to develop the alkali fuel cell that featured a stack of 10” diameter electrodes for Britain’s National Research Development Corporation. Bacon’s work garnered the interest of Pratt and Whitney which resulted in the technology being licensed and used in the Apollo space missions. A variation of the Bacon cell is still in use today in several spacecraft.

Globally, research activities are focussed on overcoming the engineering related problems that still prevent the full commercialisation of fuel cells. These problems include the initial high cost of fuel cell manufacture, the lack of infrastructure for delivery of hydrogen, and the industry's lack of knowledge and experience with this technology [94]. In order to address these issues, manufacturers must first find ways to reduce fuel cell production costs. Then, according to the field of application, a fuel cell type must be selected for which the new infrastructures can be developed. The establishment of infrastructure will require amendments in policy which address, for example, standardisation, safety codes, and regulations for fuel cell manufacture and fuel distribution. Finally, the energy industry must become aware, educated and familiarised with fuel cell technology as a means of power generation. This will occur over time as energy companies begin to adopt increasing capacity of high-efficiency and low-carbon power generating technologies and synthetic natural gas (non-fossil methane) for power generation.

Research on fuel cells is ongoing for two main reasons. The first reason is that fuel cells are an emerging technology alternative to the conventional fossil fuel based technologies and as such require significant research and development in order to facilitate commercialisation. The second reason involves the understanding of how fuel cells can change the energy supply to electric devices in the future.

Currently, one of the biggest drawbacks of fuel cells is that they are relatively more expensive than other methods of power generation; however, with economies of scale this is set to reduce. Also, considering the full cost of operation, it is rarely appreciated that the total operating costs of fuel cells might be lower, due to their increased efficiency compared to conventional technology, especially in comparison to vehicle internal combustion engines [95]. In the past, fuel cells were limited to niche applications such as powering space capsules for NASA during the 1960s. Due to the progress in R&D, manufacturing costs have declined substantially allowing for a more varied and diverse application of fuel cells. In the year 2000, fuel cell cost was far in excess of \$10,000/kW_{el} (system), although, according to research analysts a cost target of around \$400/kW_{el} must be achieved before they can be commercialised.

There are several main advantages that fuel cells offer: namely their simple design, generally high efficiency, silent operation and virtually zero emissions [96]. The electrical efficiency of a fuel cell ranges from 35 to 60%, but when used in a combined heat and power (CHP) configuration the total efficiency (electricity and heat supply) can increase to over 85% [94]. These efficiencies are a marked improvement on the 40% achieved by internal combustion engines (ICEs) in their best point (18 to 20% in real driving cycles). Fuel cells are a relatively simple design and contain no moving parts (apart from blowers and pumps in the system) meaning these devices have high durability. Depending on the fuel cell type and fuel used, the emissions tend to fall well below current standards.

Fuel cells are capable of supplying power outputs that range between 1 W_{el} up to several 10 MW_{el} (the largest installation currently being 59 MW_{el}), making them suitable for many power applications. They can be used to power small scale electronic devices such as mobile phones and personal computers. In the 1 kW_{el} –100 kW_{el} range, fuel cells are able to power both civilian and military vehicles in addition to public transportation and can also be used for auxiliary power unit (APU) applications on-board of various vehicles, from trucks to aircraft, rail and ships. Moreover, fuel cells can be used for larger scale applications which operate in the 1–100 MW_{el} range such as producing grid quality power for distribution [96].

Vehicle and public transportation applications are one of the most important application fields of fuel cells. Companies such as Toyota and Hyundai are implementing fuel cell systems into their commercial products. Conversion to a fuel cell powered vehicle would significantly reduce the number of moving parts and improve longevity. In comparison to conventional batteries, fuel cells produce higher power densities and do not require recharging as fuel is continuously flowed through the device. Due to the relatively higher power densities, fuel cells can be made smaller in order to produce the equivalent power output of commercial batteries and enable considerable savings in space and weight. Fuel cells can operate in conjunction with turbine power plants to help boost efficiency. By using the heat generated by the fuel cell and transferring this energy to a turbine power cycle (equivalent to a combined cycle gas turbine, CCGT), the overall system efficiency can be increased up to 80%.

4.2 FUEL CELL BASICS AND TYPES

A fuel cell is a device wherein a fuel, typically hydrogen, and oxygen are electrochemically combined to produce electricity, water and heat. A fuel cell differs from a battery in that the reactants are continuously supplied and replenished after consumption. Fuel cells are not limited by the internal capacity of a battery and produce electricity from an external fuel sources. The modular design of fuel cells alongside their ability to efficiently and cleanly generate electricity makes them ideal for a wide range of applications and markets [97, 98], as mentioned above. Currently, there exist a wide range of fuel cell types which are made distinct by the fuels used, electrolyte material and operating temperatures. However, all fuel cell types have in common the anode, electrolyte and cathode components that form the ‘membrane electrode assembly’ (MEA), or simply ‘the cell’.

Low temperature fuel cells include polymer electrolyte fuel cells (PEFCs), direct methanol fuel cells (DMFCs) and alkaline fuel cells (AFCs) operating between 50 and 100°C. Intermediate and high temperature PEFC (IT- and HT-PEFC) and phosphoric acid fuel cells (PAFCs) operate in the temperature range of 120 to 200°C with less constrictions on the quality of the hydrogen fuels. High temperature fuel cells such as the molten carbonate fuel cells (MCFCs), and solid oxide fuel cells (SOFCs) operate

at higher temperatures between 600 and 900°C. The main difference between low temperature and higher temperature fuel cells is the direction of ion conduction. In most low temperature fuel cells, (apart from the AFC) the fuel is oxidised (electrons are lost) at the anode and the ions subsequently travel through the electrolyte to be reduced (electrons are gained) at the cathode. In high temperature fuel cells the oxidant is reduced at the cathode to generate ions which migrate through the electrolyte to oxidise the fuel at the anode. In both cases, the flow of electrons remains unchanged. In general, high temperature fuel cells exhibit higher efficiencies and are less sensitive to fuel impurities relative to the low temperature fuel cells. Table 4.1 compares the six main types of fuel cell indicating the electrolyte used, operating temperatures, efficiency, fuel and oxidant.

Table 4.1 Overview of fuel cell types.

Fuel cell	Electrolyte and ionic transport	Operating temperature (°C)	Efficiency (%)	Fuel	Oxidising agent
PEFC	Polymer electrolyte, proton H ⁺	50–100	45–55	H ₂ (hydrogen)	O ₂ (oxygen), air
DMFC	Polymer electrolyte, proton H ⁺	40–130	20–35	CH ₃ OH (methanol)	O ₂ , air
AFC	Potassium hydroxide (KOH) solution, hydroxyl ion OH ⁻	40–90	50–60	H ₂	O ₂
PAFC	Phosphoric acid, proton H ⁺	160–220	55	Natural gas, biogas, H ₂	O ₂ , air
MCFC	Molten mixture of alkali metal carbonates, carbonate ion CO ₃ ²⁻	550–650	55	Natural gas, biogas, coal gas, H ₂	O ₂ , air
SOFC	Oxide ion conducting ceramic, O ₂ ⁻	600–950	~50–60	Natural gas, biogas, coal gas, H ₂	O ₂ , air

4.2.1 Polymer electrolyte fuel cell (PEFC)

Stringent operating conditions of pure hydrogen are required for PEFCs since this type of fuel cell can be contaminated by carbon monoxide (CO). A PEFC makes use of a solid, proton conducting polymer electrolyte such as Nafion® [98, 99] and platinum catalysts in the electrodes. The platinum catalysts currently make up the largest proportion of cost in fuel cell production and can only use ultra-pure hydrogen (99.999%) in order to avoid contamination. Figure 4.1 shows a diagram of a typical PEFC.

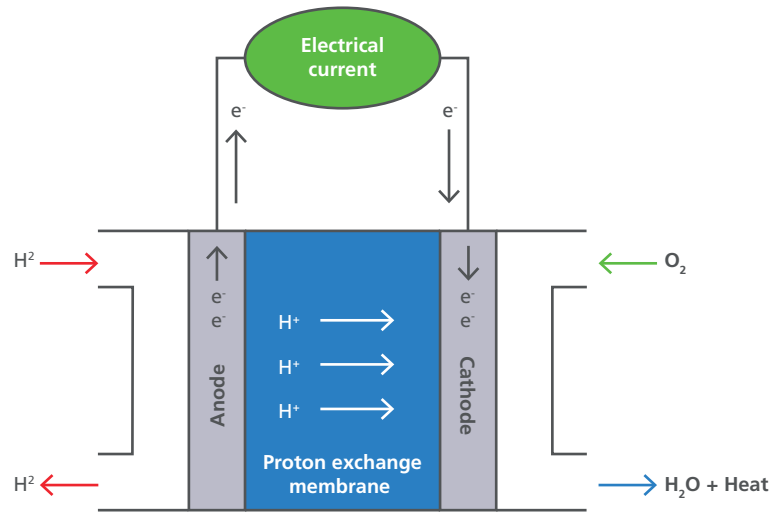
Figure 4.1 Basic fuel cell diagram for a PEFC.

Hydrogen (H₂) is supplied to the anode and is subsequently ionised to produce a proton (H⁺) and an electron (e⁻). The hydrogen ion H⁺ (proton) migrates through the proton exchange membrane (for instance Nafion®) across to the cathode while the electron e⁻ moves through an external circuit to deliver electricity. When two electrons reach the cathode they recombine with two protons H⁺ which go on to react with oxygen (O₂) from the air supply to form water. This reaction releases heat and is therefore called ‘exothermic’. The anode and cathode reactions are shown in Equation 4.1 and Equation 4.2, respectively, with the overall PEFC reaction shown in Equation 4.3. Equation 4.1 demonstrates what is commonly known as the hydrogen oxidation reaction (HOR) and Equation 4.2 shows the oxygen reduction reaction (ORR).

Anode	$2\text{H}_2 \rightarrow 4\text{H}^+ + 4\text{e}^-$	Equation 4.1
Cathode	$\text{O}_2 + 4\text{H}^+ + 4\text{e}^- \rightarrow 2\text{H}_2\text{O}$	Equation 4.2
Overall	$2\text{H}_2 + \text{O}_2 \rightarrow 2\text{H}_2\text{O}$	Equation 4.3

The PEFC typically operates at temperatures between 50 to 100°C and hydrogen pressures between 100–300 kPa [83, 100, 101] with an electrical efficiency ranging from 45 to 55% and benefits from not being limited by the Carnot efficiency associated with thermal conversion of fuels, such as in internal combustion engines (ICEs) [102]. The excess heat produced during the fuel cell reaction can be reused to further increase the efficiency to above 90% through CHP use. PEFCs are often used in vehicle applications and to power mobile devices due to their relatively low operating temperatures, rapid start-up times, low weight, and compact design.

One of the main drawbacks of the PEFC is contamination of the platinum catalyst with impurities such as carbon monoxide. Many further challenges still remain including the cost of platinum, and durability under fluctuating load conditions. Companies Johnson Matthey and Intelligent Energy are two British firms active in the area of commercialising PEFC catalysts and systems, respectively.

4.2.2 Direct methanol fuel cell (DMFC)

A variation of the PEFC is the DMFC which uses methanol (CH₃OH) directly at the anode instead of hydrogen. This type of fuel cell is between 20 and 35% (electrical) efficient due to the slow rate of methanol oxidation reaction at the anode (fuel electrode). One drawback is that methanol can be absorbed into the proton exchange membrane and be transported to the cathode, thus reducing the power delivered; however, the advantage is that liquid fuels have a higher energy density per volume than gaseous fuels. Figure 4.2 shows the operating diagram of a typical DMFC.

Figure 4.2 Basic fuel cell diagram for a DMFC.

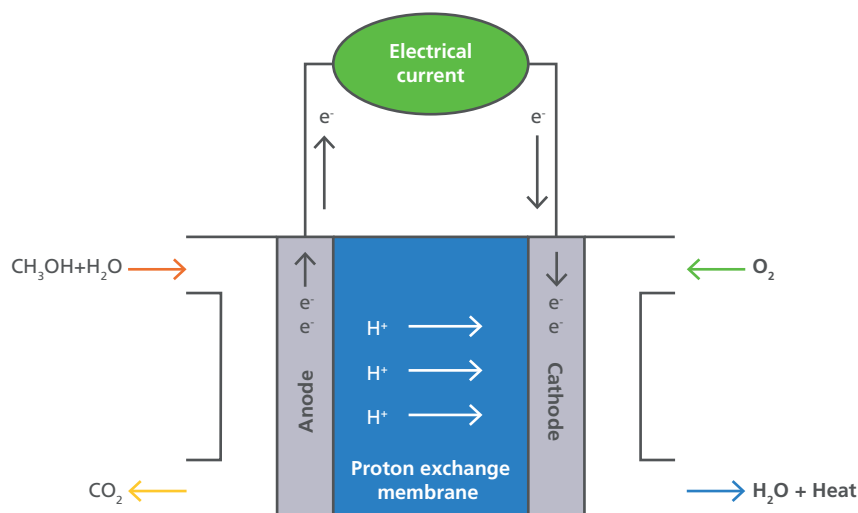

The anode and cathode reactions are shown in Equation 4.4 and Equation 4.5, respectively, with the overall DMFC reaction shown in Equation 4.6. It is evident from these reactions that CO₂ is produced, however, methanol can be produced from biomass in a similar way to ethanol hence making the overall fuel life cycle carbon-neutral.

Anode	$2\text{CH}_3\text{OH} + 2\text{H}_2\text{O} \rightarrow 2\text{CO}_2 + 12\text{H}^+ + 12\text{e}^-$	Equation 4.4
Cathode	$3\text{O}_2 + 12\text{H}^+ + 12\text{e}^- \rightarrow 6\text{H}_2\text{O}$	Equation 4.5
Overall	$2\text{CH}_3\text{OH} + 3\text{O}_2 \rightarrow 2\text{CO}_2 + 4\text{H}_2\text{O}$	Equation 4.6

4.2.3 Alkaline fuel cell (AFC)

AFCs use an electrolyte based on a strong alkali such as sodium or potassium hydroxide. In this type of fuel cell, hydrogen and hydroxide ions (OH^-) moving through the electrolyte react to form water (H_2O) and in the process release electrons into the external circuit. At the cathode, oxygen (O_2) and H_2O combine with the electrons from the external circuit to produce the OH^- ions. Figure 4.3 shows a diagram of a typical AFC.

Figure 4.3 Basic fuel cell diagram for an AFC.

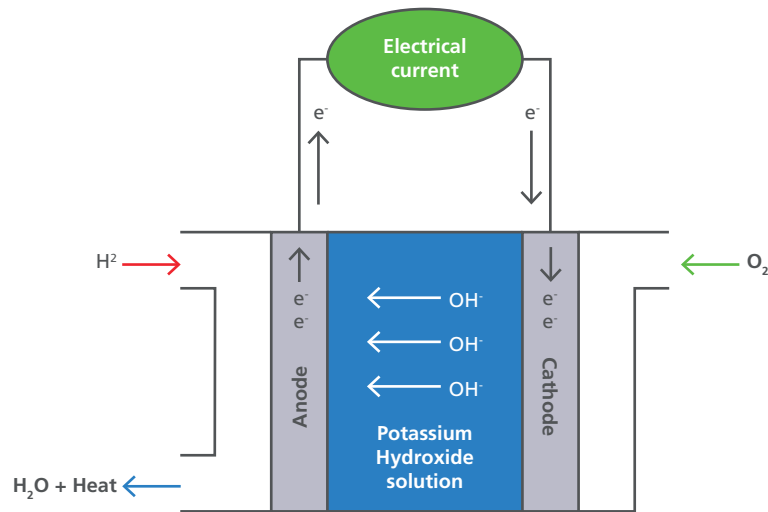

The anode and cathode reactions are shown in Equation 4.7 and Equation 4.8, respectively, with Equation 4.9 demonstrating the overall AFC reaction.

Anode	$2\text{H}_2 \rightarrow 4\text{OH}^- + 4e^-$	Equation 4.7
Cathode	$\text{O}_2 + 2\text{H}_2\text{O} + 4e^- \rightarrow 4\text{OH}^-$	Equation 4.8
Overall	$2\text{H}_2 + \text{O}_2 \rightarrow 2\text{H}_2\text{O}$	Equation 4.9

The AFC has one of the higher electrical efficiencies of all fuel cell types ranging between 50–60% (operating on pure oxygen, not air) and were used by NASA during the Apollo missions and on board their space shuttles [98]. A major drawback of AFCs is that the electrolyte reacts with the carbon dioxide (CO_2) in the air feed to form an insoluble carbonate meaning that only pure H_2 and O_2 can be used with this device. This is the reason for the very high electrical efficiency. AFCs were being phased out in favour of PEFCs but have gained new attention due to the use of cheaper nickel catalysts in place of platinum. One major company working in the field, AFC Energy, resides in the UK.

There are three main types of AFCs: mobile electrolyte, static electrolyte, and dissolved fuels alkaline fuel cells. In mobile electrolyte AFCs, the KOH solution is circulated around the fuel cell which facilitates the replenishment of the electrolyte. In the static electrolyte AFCs, the electrolyte is contained in a matrix material between the electrodes. In this version of the AFC, it is difficult to replace

the electrolyte in the event of becoming carbonated; hence it is necessary to use a pure oxygen feed at the cathode. The dissolved electrolyte AFC is fairly uncommon and features an electrolyte mixed with the fuel which in this case is either ammonia (NH₃) or hydrazine (N₂H₄) [98]. Nevertheless, the two latter examples show the high versatility of fuel cells in transforming practically any fuel that contains hydrogen in one form or the other into electrical and thermal energy, either directly or with an intermediate step (reforming, cf. Chapter 3).

4.2.4 Phosphoric acid fuel cell (PAFC)

The PAFC was originally known as the acid fuel cell due to using a sulphuric acid electrolyte. However, sulphuric acid has a relatively high vapour pressure and undergoes reduction between 80 to 100°C. As a result, phosphoric acid was used instead at concentrations greater than 95% which is also known as pyrophosphoric acid (H₄P₂O₇). The electrolyte is held in a silicon carbide (SiC) porous matrix via capillary forces. Phosphoric acid freezes at 42°C, hence PAFCs are constantly operated between 160 to 220°C throughout the lifetime of the cell. Unlike the PEFC and AFC, the PAFC is more tolerant to impurity levels (1–3%) of CO and CO₂. Figure 4.4 shows a diagram of a typical PAFC.

Figure 4.4 Basic fuel cell diagram for a PAFC.

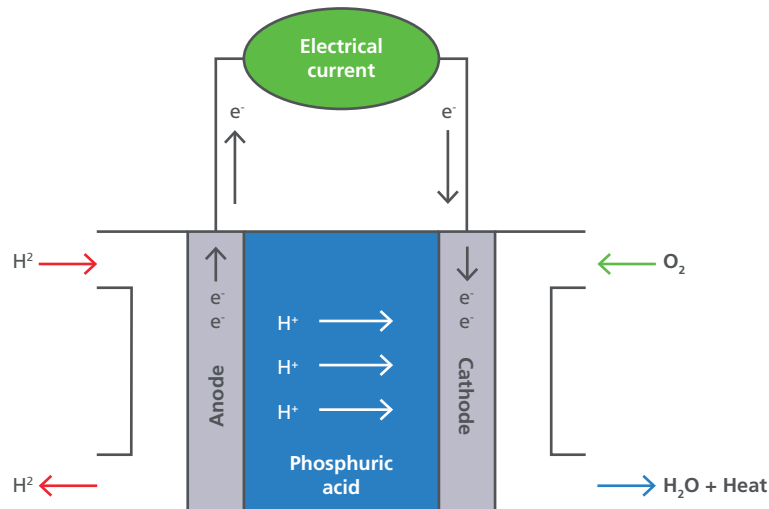

The anode and cathode reactions are shown in Equation 4.10 and Equation 4.11 with the overall PAFC reaction shown in Equation 4.12.

Anode	$2\text{H}_2 \rightarrow 4\text{H}^+ + 4\text{e}^-$	Equation 4.10
Cathode	$\text{O}_2 + 4\text{H}^+ + 4\text{e}^- \rightarrow 2\text{H}_2\text{O}$	Equation 4.11
Overall	$2\text{H}_2 + \text{O}_2 \rightarrow 2\text{H}_2\text{O}$	Equation 4.12

This type of fuel cell was the first to establish itself on the markets and has accumulated more than 1 million operational hours over the many decades. The primary application for PAFCs was as backup power units, and in combined heat and power systems in the region of 200 to 400 kW_{el}. Although PEFC seem to have taken over

most of the market, PAFC are still built by Fuji in Japan and employed as medium sized CHP units.

4.2.5 Molten carbonate fuel cell (MCFC)

The operating temperature for MCFCs range between 550 and 650°C. They are referred to as one of the two high temperature fuel cells, and have an electrical efficiency of typically 55%. The electrolyte used by this type of fuel cell is a carbonate ion-conducting mixture of sodium and potassium carbonates which are in the liquid phase at the operating temperature and contained in a ceramic matrix of lithium aluminium oxide (LiOAlO_2) by capillary forces. MCFCs are able to use hydrocarbon fuels as well as H_2 since this type of fuel cell is fully tolerant to CO and CO_2 . The MCFC electrolyte uses carbonate ions (CO_3^{2-}) for charge transport and so it is necessary to feed CO_2 to the cathode in order to produce the carbonate ions and maintain a stoichiometric supply. At temperatures above 600°C, carbon-containing fuels such as simple hydrocarbons can directly be transformed (reformed) within the fuel cell to deliver hydrogen and CO which are then oxidised by the oxygen carried by the carbonate ions. Recycling of the CO_2 that is produced at the anode back to the cathode is a common way of supplying the necessary CO_2 to the cathode. Figure 4.5 shows hydrogen operation of an MCFC, in which case there is a need for an external CO_2 feed to compensate for any losses of CO_2 from the internal cycle. Use of hydrogen fuels is therefore not so straight forward, whereas the use of methane (CH_4) results in CO_2 being formed at the anode side which can then be re-used by being added to the cathode gas stream. Figure 4.5 shows a diagram of a typical MCFC.

Figure 4.5 Basic fuel cell diagram for an MCFC.

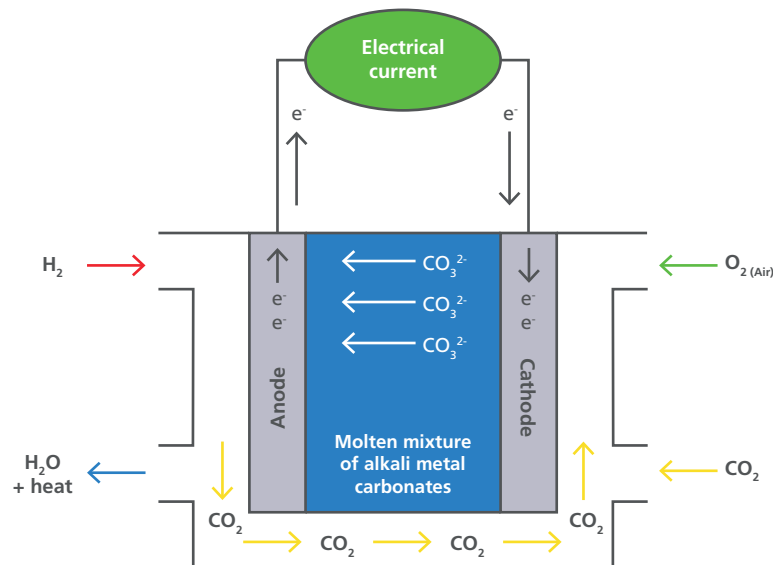

The anode and cathode reactions for hydrogen operation are shown in Equation 4.13 and Equation 4.14, respectively, and the overall MCFC reaction is shown in Equation 4.15.

Anode	$2\text{H}_2 + 2\text{CO}_3^{2-} \rightarrow 2\text{H}_2\text{O} + 2\text{CO}_2 + 4\text{e}^-$	Equation 4.13
Cathode	$\text{O}_2 + 2\text{CO}_2 + 4\text{e}^- \rightarrow 2\text{CO}_3^{2-}$	Equation 4.14
Overall	$2\text{H}_2 + \text{O}_2 \rightarrow 2\text{H}_2\text{O}$	Equation 4.15

4.2.6 Solid oxide fuel cell (SOFC)

SOFCs operate at high temperatures between 600 and 950°C and are made distinct by the solid-phase oxygen ion-conducting electrolyte [97–99]. The electrolyte is typically fabricated from ceramics such as yttrium or scandia-stabilised zirconia (YSZ or ceria, CeO₂). Similar to the MCFC, the SOFC is fully tolerant to CO and CO₂ and is capable of oxidising short-chained hydrocarbons (methane, propane, but also ethanol) directly at the anode. At temperatures above 600°C, natural gas can be supplied directly to the SOFC as a fuel. In some instances, natural gas will need some level of catalysed pre-reforming when the content of propane and butane added to increase the heating value of natural gas in winter is too high. Most SOFCs incorporate a nickel catalyst and thus can internally convert methane (CH₄) into H₂, CO and CO₂ at temperatures above 600°C, removing the need for external reforming equipment.

Natural gas mainly consists of methane and is deemed a clean fuel [102] but besides producing carbon dioxide when burnt in itself is a greenhouse gas. Converting methane to hydrogen allows the possibility to capture the CO₂ from the reforming for processing in a CCS scheme and avoids CH₄ leakages from the natural gas grid since the gas distributed would then be hydrogen. The relative abundance of natural gas would make the SOFC an ideal candidate for rapid commercialisation and qualify it as a transitional technology bridging the conversion from natural gas to methane (synthetic natural gas, SNG) and hydrogen infrastructures. A further advantage of the SOFC is the high electrical efficiency (>55%) [97, 103–105].

Another benefit of SOFCs is that they do not contain any moving parts or corrosive electrolytes. Therefore, they are more durable and are a more reliable power generation system that requires less maintenance. The SOFC manufacturing process is well established and originates from the production of electronic ceramic components. Furthermore, SOFCs do not require expensive catalysts to operate and are able to use a range of fuels such as methane, natural gas, biogas, sewage and landfill gas, syn-gas from coal or biomass gasification which eliminates the need for the costly reforming of methane for the production of hydrogen. In addition, SOFCs have the added advantage of low noise emissions. Moreover, the high operating temperature results in high-grade exhaust heat which can give a wider choice of combined heat and power options. Figure 4.6 shows a diagram of a typical SOFC. It is possible to enhance the total system efficiency to above 90% through CHP schemes when using the reaction heat for heating purposes or for steam generation. Electrical efficiencies up to 80% are possible in conjunction with micro turbines that would use the high temperature exhaust gases of the SOFC

to produce steam for a steam turbine cycle. Such efficiencies have not been achieved by any other combination of technologies.

Figure 4.6 Basic fuel cell diagram for an SOFC.

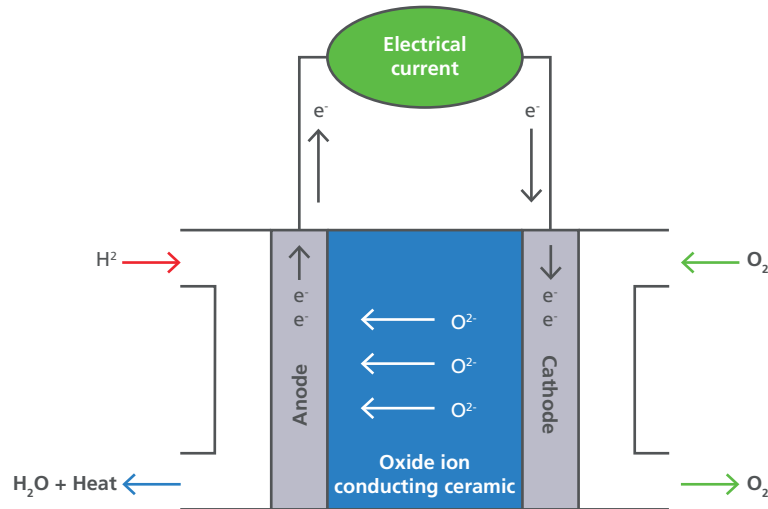

The anode and cathode reactions for hydrogen operation are shown in Equation 4.16 and Equation 4.17, respectively, with the overall SOFC reaction shown in Equation 4.18.

Anode	$2\text{H}_2 + 2\text{O}^{2-} \rightarrow 2\text{H}_2\text{O} + 4\text{e}^-$	Equation 4.16
Cathode	$\text{O}_2 + 4\text{e}^- \rightarrow 2\text{O}^{2-}$	Equation 4.17
Overall	$2\text{H}_2 + \text{O}_2 \rightarrow 2\text{H}_2\text{O}$	Equation 4.18

4.3 APPLICATIONS OF FUEL CELLS

Fuel cell applications can be broadly categorised into three areas:

- Transport,
- Portable, and
- Stationary applications.

Fuel cells will especially attract interest and gain first (niche) market access in application fields where they can offer decisive advantages and marketing value ('added value') above the incumbent, largely fossil technologies [106].

4.3.1 Transport

Fuel cells for transport applications are employed on electric or hybrid vehicles to supply on-board electric power. They form part of the power train and provide propulsive power to a vehicle either directly or indirectly (i.e. as range extenders) via the vehicle battery. In practically all cases the fuel cell employed in vehicles will be a PEFC. These vehicles will be fuelled by high-purity hydrogen (see Section 4.2.1). Once natural gas, liquefied natural gas (LNG), or synthetic natural gas (SNG) become more popular on larger vehicles (where hydrogen will not supply sufficient range),

high temperature fuel cells could be more widely employed in transport due to their ability to directly convert these fuels without additional processing.

Types of vehicles where fuel cells can offer specific advantages include:

- Forklift trucks and airport baggage trucks,
- Two- and three-wheeler vehicles such as scooters,
- Light duty vehicles (LDVs) such as cars and vans,
- Buses and trucks,
- Trains and trams,
- Ferries and smaller boats, and unmanned undersea vehicles (UUVs),
- Manned light aircraft,
- Airliners, and Unmanned aerial vehicles (UAVs).

Up until recently, fuel cell LDVs have experienced little popularity, however this is set to change as car manufacturers have started first rollout of commercial fuel cell electric vehicles (FCEV) in 2016/17, namely Hyundai and Toyota, with several others to follow suit. Initially, countries which have the most developed hydrogen refuelling infrastructure such as Japan, Germany and the USA, will be expected to have the largest number of fuel cell vehicles on the road. Rollout will spread outside of these countries once the market and fuel infrastructures become more established over time.

The fuel cell bus sector is growing on yearly basis, with more prototypes being launched onto the scene. Europe, Japan, Canada, and the USA have demonstrated successful deployments of these vehicles, yet the high capital cost presents a large hurdle for commercialisation. However, it is anticipated that the cost of fuel cell buses will be comparable to that of diesel-hybrid buses by 2020. Again, the investment premium has to be balanced with the savings in everyday operation with both fuel and maintenance/repair costs being lower than with conventional ICE buses.

To date, 'niche' transport is made up of several sub-applications with varying levels of commercial success. Materials handling vehicles make up over 90% of niche transport shipments where PEFC dominate. So far, this market has shown a lot of success in the USA. Unmanned aerial vehicles (UAVs), e-bikes and trains are under development for mass deployment in the near future.

Auxiliary Power Units (APU) are electricity generators on vehicles that will not supply energy for propulsion but on-board electricity for the various electric loads. On long-haul lorries these are the so-called 'hotel loads' for anything from heating, air-conditioning, entertainment (TV), up to preparing meals. When parked, many countries prohibit running the main engine of lorries so that other means of providing electricity are required. Similar problems exist for ships moored in harbours and aircraft at gates at airports. Ports will want to reduce the operation of main engines due to the considerable pollution from the emissions of the engines being run under very inefficient operating conditions. Supplying electricity from fuel cells offers substantial increases in efficiency, low to no emissions, low noise, no vibration,

and the potential use of the water generated for other functions on the vehicle (e.g. toilet water).

4.3.2 Portable

Portable fuel cells can be defined as fuel cells which are either built-in to electric devices or tools, or charge products that are designed to be moved (carried) around. Portable fuel cells can be used to power the following:

- Military equipment such as soldier power and skid mounted fuel cell generators,
- Portable products including torches and trimmers,
- Small personal electronics like mp3 players, cameras and mobile phones,
- Large personal electronics such as laptops, printers and radios, and
- Demonstration kits and toys.

Fuel cells are being designed in different sizes ranging between 5 and 500 W_{el} in order to power the wide variety of portable products. A fuel cell that has an output of less than 1 W_{el} is defined as a micro fuel cell the likes of which are being sold commercially for small personal electronics, phone chargers, demonstration kits, and toys applications. Large personal electronics such as laptops operate at up to 25 W meaning much larger fuel cells are required for this application. DMFC are popular for portable applications and have experienced successful deployment throughout the European leisure market selling over 50,000 units on a commercial basis without any funding. Portable PEFCs and DMFCs are set to either replace or considerably augment battery technology in some application areas, such as motor homes.

4.3.3 Stationary

Stationary fuel cells are units which typically generate electricity (and heat) for use in buildings and homes. This type of application includes combined heat and power (CHP), uninterruptible power systems (UPS) and primary (decentralised) power units (see next section for distributed and peak shaving generation). MCFC and SOFC can be employed to support the electricity grid in the form of 'distributed generation' (see further discussion in Chapter 6). This avoids or defers building additional central balancing power, for instance to compensate for large load fluctuations (often caused by industry, e.g. steel mills), upgrading grids when load is added (e.g. new residential developments), and for balancing fluctuations from renewable electricity generation. Within the confines of an industrial estate or large building block, distributed generation can also avoid excessive payments for peaks in power demand (so-called peak shaving).

Large stationary units typically generate power in the MW_{el} range for primary power applications. The aim is to develop these types of units to reduce peak demand on the grid and support areas with weak electricity grid infrastructure. In addition, these units can also be used to provide grid expansion nodes. PAFCs, MCFCs and SOFCs are common choices for large stationary applications. These types of fuel cells are mostly manufactured in the USA and Japan. When the (waste) heat generated in the electrochemical processes – which would otherwise be rejected to the environment via cooling radiators – is captured and put to use in a heating system, these systems

qualify as combined heat and power (CHP) units. Generally (with a system electrical efficiency typically in the range of 50%) this will be about half of the fuel energy fed into the system. At electric power ratings of around 1 to 2 kW_{el}, these systems are termed micro-CHP. Fuel cell micro-CHP systems offer the highest electrical efficiency of any CHP technology, >60% to AC power for some variants, nearly a factor of 2 above many conventional thermal power stations [107], while also enabling local use of waste heat without the need for distributed heating networks. Even with the use of natural gas, fuel cell micro-CHPs systems can enable well above 30% immediate reduction in CO₂ emissions [108, 109].

High temperature off-heat from MCFC and SOFC can be used for a variety of applications, including steam generation and coupling with a steam turbine to exploit the exhaust energy content. In industry, steam generation can be of value, as will be the coupling with absorption and adsorption cooling systems to deliver cold from heat. The high purity of carbon dioxide in exhaust streams from MCFC and SOFC fed with natural gas and especially pure methane (SNG) allows facile carbon capture and the use of the carbon dioxide for instance in greenhouse vegetable growing or food industry. Fuel cell systems operating on internal reforming can be operated to produce an excess of hydrogen so that from their exhaust stream hydrogen could be separated out, in this way offering an additional flexibility of the use of the fuel cell installation as a device for hydrogen co-production.

PEFCs and SOFCs are commonly used as CHP units which range between 0.5 and 10 kW_{el}. Historically, PAFC exploited this market first with typical installed capacities of 300 kW_{el} but are today hardly present as commercial products. The heat generated by these units can be used to supply hot water which improves the overall efficiency of the system up to 80 to 95%. By the end of 2016, more than 50,000 such residential CHP units with 0.7 kW_{el} had been deployed throughout Japan. Residential CHP units have also been deployed in South Korea, Germany, and across the EU, but like in Japan, purchases have relied upon government subsidies or demonstration projects. The current low volume of production means the units are still overly expensive. This will be further addressed in Chapter 8. The company Ceres Power, developing small SOFC systems, is one example for UK industry involvement in this sector.

4.3.4 Uninterruptible power

Uninterruptible Power Supply (UPS) units provide guaranteed power supply in the event of grid failure. This sector can be divided into five categories:

- Off-line short run-time systems for use in telecommunication base stations,
- Off-line extended run-time systems for use in critical communication base stations such as Terrestrial Trunked Radio (Tetra) networks,
- Off-line extended run-time rack mountable systems for use in data centres,
- On-line rack mountable systems for use in data centres, and
- Off-line systems for use in residential homes.

The first three categories are the most developed. Selection of fuels depends on the region, for example LPG and natural gas are more prevalent in Asia, hydrogen is

widely available in the USA, hydrogen and methanol are being trialled in Europe. Due to the high cost of maintaining UPS systems based on batteries and diesel generators, fuel cells meet a first competitive market opportunity here.

4.3.5 Special markets and applications

Fuel cells are also known to be employed in other fringe applications, as for example fire protection and emergency energy supply. 400 kW_{el} PAFC units are being employed to deliver the cathode off-gas which is reduced in oxygen content (the oxygen having been consumed to form water) to about 15 to 16% to feed the ventilation systems of data server buildings. These buildings are extremely critical to protect since the value of the data stored is immense. At the same time, fire protection is difficult because the use of water within the building is not favoured since it will destroy the equipment it is supposedly meant to protect. The oxygen-depleted air is sufficient for breathing (equivalent to working at 2,500 m altitude) whilst building materials will not be flammable anymore under these conditions. As mentioned above, fuel cells will in the future provide electricity on-board electric vehicles to substantially expand their range. As will be further discussed in Chapter 6, these fuel cells could also be employed to provide electricity to a building or to electric tools. FCEV could be considered as power generators on wheels that will provide electricity as long as the content of the hydrogen tank lasts (which would be several hours at maximum power). Once this concept has been embraced in its full implications, it will be realised that this opens up several opportunities current vehicle technology does not offer (describing an 'enabling' technology):

- Supply of electricity to houses in case of grid failure (UPS), as Toyota is already offering as a standard option for their FCEV in Japan, or
- Operation of FC hybrid vehicles (with battery and fuel cell system) as grid balancing storage and generation systems when parked and connected to a charging station.

Whilst the first option is rather obvious, the second builds on the possibility to use battery electric vehicle (BEV) that are parked and charging as two-way storage for the electricity grids. This has already been explored in several concept studies. The addition of a fuel cell allows for additional electric power to be integrated into the grid to cover peak load, compensate for fluctuations from renewable electricity from wind and solar, or generally deliver balancing and support power to the grid operator. The total generating capacity of a UK LDV fleet completely converted to FCEV could well be in the order of 600 GW_{el}. Clearly, regulation and suitable, incentivising tariffs are needed here and will be discussed in Chapter 8.

4.4 ALTERNATIVE FUELS FOR FUEL CELLS

Fuels cells are generally perceived to operate with pure hydrogen. Although hydrogen is considered to being an energy carrier of the future, there are a number of problems related to hydrogen generation and storage that must be overcome before it can be implemented on a wide scale. One of the biggest problems is that, at the present time, an estimated 97% of hydrogen is produced by reforming hydrocarbons [42]. Even with highly optimised large-scale production, between 15 and 25% of the fuel

value of the hydrocarbons is lost during this process, resulting in an overall (lifecycle) carbon footprint higher than that of direct natural gas use. Though this is compensated for by the higher electrical efficiency of fuel cells, production of hydrogen from fossil sources is clearly not ideal.

Since the high temperature fuel cells MCFC and SOFC use nickel anodes this allows direct use of simple hydrocarbons (e.g. methane or propane) and carbon monoxide. These fuel cells therefore can also operate on other gases than pure hydrogen. Such fuels include processed (pre-reformed) bio diesel, jet fuel, and alcohols [110, 111]. Methane contributes in excess of 95% to natural gas, making it an ideal fuel for SOFCs, enabling them to bridge the transition from fossil to renewable gaseous fuels.

Using methane as a fuel has led to the development of new anode materials for internal conversion to CO_2 and H_2O which evades the need for external reformation or production of hydrogen. Elimination of the reforming step decreases system complexity, increases the electrical efficiency, and avoids the necessity to dilute fuels with steam. Hence direct internal reforming (DIR) is the preferred route for using hydrocarbon fuels in fuel cells.

Hydrogen can be bound into a variety of compounds, including of course methane and methanol, but also ammonia (NH_3), borates, or even hydrogen sulphide (H_2S). All these can be split again at relatively mild temperatures on catalysts, making them potential fuels for fuel cells. This considerably widens the application of fuel cells in small scale applications. A UK company is developing such fuel – fuel cell combinations with borate and ammonia salts for small scale, telecommunication applications in Africa and India. The lack of hydrogen infrastructure is overcome by employing an easy-to-use, cheap, and abundant solid fuel that easily releases hydrogen.

4.5 CONCLUSIONS

Fuel cell technology has been in existence since the early 19th century and has seen substantial development over the course of time from being used on the Apollo space missions to powering today's commercial road vehicles like the Toyota Mirai. Fuel cells have a wide range of applications, depending on their physical properties (temperature of operation, weight, size, efficiency) and fuel: ranging from high-purity hydrogen up to natural gas and ethanol, to name but a few of the options. In recent times, fuel cells have become highly versatile as their usage covers transport, portable and stationary applications.

In general fuel cells offer considerably higher electrical efficiencies compared to the incumbent, mostly fossil fuelled technologies. Fuel cell micro-CHP competes with micro-internal combustion engines and Stirling engines with electrical efficiencies of 35 and 12%, respectively. In comparison, the equivalent fuel cell systems deliver electricity at 50 to 60% net electrical efficiency. This is largely true independent of electric power rating. Fuel cell systems between 1 kW_{el} and 10 MW_{el} will have similarly high electrical efficiencies. Owing to the integration of such systems at or

close to 'point of use' the waste heat can be integrated into building heating systems or industrial process heat delivery, in the case of high temperature fuel cells including steam generation, air conditioning, and refrigeration.

The flexibility of using different fuels with fuel cell systems (hydrogen, natural gas, methane, methanol, ethanol, propane, LPG etc.) makes a strong case for their adoption in diversifying the heating and electricity fuel base in the UK. Natural gas could be used more efficiently in the short term, with biomass-based gases replacing in the medium term, followed by hydrogen and synthetic natural gas (SNG) in a future pipeline network, as proposed by the UK HFC Roadmap [112].