

The influence of oil-based friction modifier quantity on tram braking distance and noise

Galas, Radovan; Omasta, Milan; Klapka, Milan; Kaewunruen, Sakdirat; Krupka, Ivan; Hartl, Martin

DOI:

[10.24874/ti.2017.39.02.06](https://doi.org/10.24874/ti.2017.39.02.06)

License:

Creative Commons: Attribution-NonCommercial (CC BY-NC)

Document Version

Publisher's PDF, also known as Version of record

Citation for published version (Harvard):

Galas, R, Omasta, M, Klapka, M, Kaewunruen, S, Krupka, I & Hartl, M 2017, 'The influence of oil-based friction modifier quantity on tram braking distance and noise', *Tribology in Industry*, vol. 39, no. 2, pp. 198-206. <https://doi.org/10.24874/ti.2017.39.02.06>

[Link to publication on Research at Birmingham portal](#)

Publisher Rights Statement:

Checked for eligibility: 04/07/2017

General rights

Unless a licence is specified above, all rights (including copyright and moral rights) in this document are retained by the authors and/or the copyright holders. The express permission of the copyright holder must be obtained for any use of this material other than for purposes permitted by law.

- Users may freely distribute the URL that is used to identify this publication.
- Users may download and/or print one copy of the publication from the University of Birmingham research portal for the purpose of private study or non-commercial research.
- User may use extracts from the document in line with the concept of 'fair dealing' under the Copyright, Designs and Patents Act 1988 (?)
- Users may not further distribute the material nor use it for the purposes of commercial gain.

Where a licence is displayed above, please note the terms and conditions of the licence govern your use of this document.

When citing, please reference the published version.

Take down policy

While the University of Birmingham exercises care and attention in making items available there are rare occasions when an item has been uploaded in error or has been deemed to be commercially or otherwise sensitive.

If you believe that this is the case for this document, please contact UBIRA@lists.bham.ac.uk providing details and we will remove access to the work immediately and investigate.

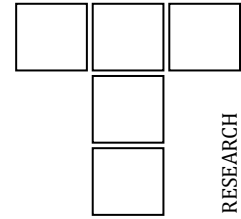
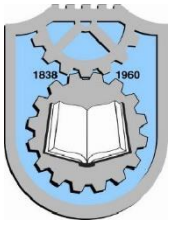

Case Study: the Influence of Oil-based Friction Modifier Quantity on Tram Braking Distance and Noise

R. Galas^a, M. Omasta^a, M. Klapka^a, S. Kaewunruen^b, I. Krupka^a, M. Hartl^a

^aBrno University of Technology, Technická 2896/2 Brno, Czech Republic,

^bUniversity of Birmingham, Edgbaston Birmingham B15 2TT, United Kingdom.

Keywords:

Adhesion
Braking distance
Friction modifier
Noise
Wheel-rail contact

ABSTRACT

In the present study, the twin disc machine and the light rail system was employed in order to investigate the ability of oil-based friction modifier (FM) to optimize adhesion and to reduce noise. The risks associated with poor adhesion conditions after the application of FM were evaluated. Both laboratory and field experiments showed that if the contact is overdosed by FM, the poor adhesion, which results in the extension of braking distance, can occur. In contrast, the smaller quantities do not cause critical adhesion but the effect of FM on the noise reduction is negligible. This study indicates that it can be quite difficult to achieve a reasonable noise reduction without a significant impact on braking distance of tram when the oil-based FM is applied. The field experiments also showed that the carry distance of FM is rather limited, approximately 100 m.

Corresponding author:

Galas Radovan
Brno University of Technology,
Technická 2896/2 Brno,
Czech Republic.
E-mail: galas@fme.vutbr.cz

© 2017 Published by Faculty of Engineering

1. INTRODUCTION

In the last decade, friction modifiers (FMs) have been used in order to control friction in wheel-rail contact. The solid FM was already employed in Vancouver, Canada by the end of the eighties because the new track was corrugated a few months after its opening [1]. This investigation showed that the application of solid FMs can suppressed roll-slip oscillation which is a one of the initiation mechanisms of corrugation [1]. Subsequently, the liquid version of FM (water-based FM) was developed in 1996. Eadie et al. [2] reported that the water-based FM can reduce both squeal and flanging noise. Then, other authors showed by field tests that the water-

based FMs are able to delay or completely avoid the corrugation formation for different wheel-rail systems [3-5]. Tomeoka [6] and Suda [7] reported on-board friction control systems for trains where FMs were sprayed on the top of the inner rail at curves. Their findings have shown that both lateral and tangential forces as well as lateral force fluctuation were reduced after the application of FM [7]. The positive influence of water-based FM on wear and, in particular, on rolling contact fatigue was described in [8] where coal trains were used.

Beside the noise and corrugation reduction, the effect of FMs on adhesion has been studied in recent years [9-11]. Areiza et al. [9] measured

the coefficient of friction (COF) on the rail using a hand-pushed tribometer when oil-based FMs were manually applied on the top of rail. It was observed that FMs can cause a low COF, even lower or the same as in the case of flange lubricants. Similar findings were reported for the laboratory investigations where commercial oil-based FMs and a ball-on-disc apparatus were used [10]. Moreover, Lundberg et al. [11] reported that too much FM results in an unacceptably low friction coefficient (0.13-0.16), also for water-based FMs. All these studies pointed out that FM can be risky in terms of critical adhesion which can result in an unacceptably long braking distance.

An application of FMs seems to be a suitable approach to the reduction of noise, vibrations and corrugation which represent one of the most important problems of railway transportation, especially in urban areas. However, the recently published articles [9-11] indicate that oil-based FMs can have a negative impact on traction or braking. With respect to these articles, the aim of this case study is to clarify the hypothesis that oil-based FMs are able to optimize adhesion and reduce noise emitted by the contact without a serious risk of adhesion loss. For this purpose, the laboratory experiments using twin-disc machine was carried out at first. Subsequently, FM was used in a real track in Brno (Czech Republic). This track is characterized by corrugation and unpleasant noise which represent the typical problems in curves [12]. The conclusions of this article can bring important findings both for safety of rail transportation and for railway owners.

2. MATERIAL AND METHODS

2.1 Twin-disc machine

The used twin-disc machine is schematically depicted in Fig. 1. The wheel-rail contact is simulated using a pair of discs with a diameter of 40 mm. Both discs are made from the bearing steel 100CrMn6 with hardness of 60 HRC and initial roughness of Ra 0.4 μm. The upper disc representing the wheel is cylindrical whereas the lower disc is rounded with a radius of 50 mm. This contact configuration leads to the elliptical contact area (according to the Hertz theory, see Fig. 1b) which is typical for the real

wheel-rail contact. Each disc is independently driven by an AC motor with shaft encoder; thus, the slide-to-roll ratio (SRR) in the contact can be accurately set and controlled according to the following equation:

$$SRR = 2 \cdot \frac{u_1 \cdot r_1 - u_2 \cdot r_2}{u_1 \cdot r_1 + u_2 \cdot r_2} \quad (1)$$

where u_1 and u_2 are the entrainment speeds of discs and r_1 and r_2 are the disc diameters. The mean speed can be controlled over the range of 0 to 2 m/s.

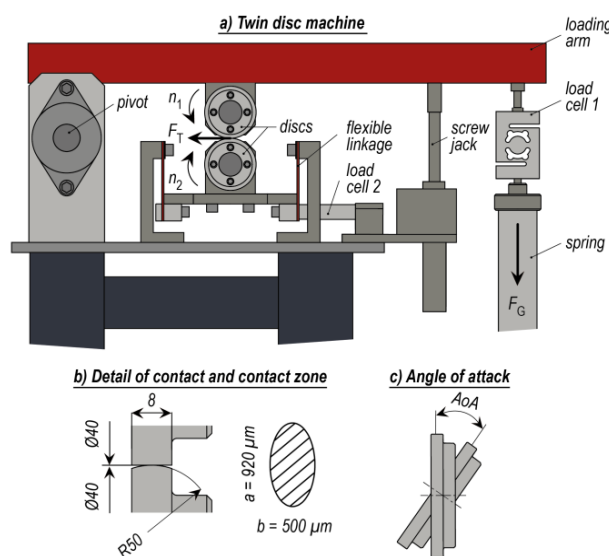

Fig. 1. (a) Twin-disc machine, (b) detail of contact and (c) AoA.

The required contact pressure is realized by the spring-screw loading system which is located, as well as the load cell for normal force, at the end of the loading arm, see Fig. 1a. Quick unloading of the contact is ensured by an AC motor-driven screw jack. The lower disc is mounted on the steel plate which is suspended on the flexible linkages. These linkages allow for a transfer of friction force from the contact to the load cell for friction force. Based on these data, the adhesion coefficient is evaluated:

$$\mu = \frac{F_T}{F_N} \quad (2)$$

where F_T and F_N are the friction and normal force respectively. Beside the friction and normal forces, temperature and air humidity can be measured and controlled using the environmental chamber. Moreover, the support of the lower disc enables to set a different angle of attack (AoA); thus, the passage of a vehicle through a curve is simulated, see Fig. 1c. AoA can be adjusted in the range from -10° to 10° .

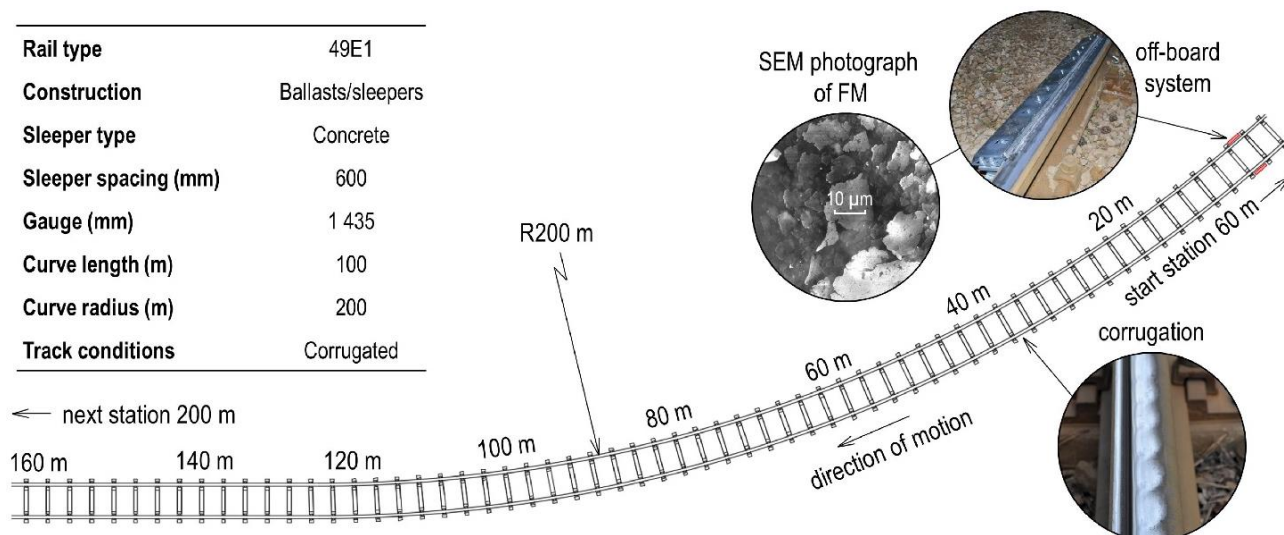

Fig. 2. Testing curve of light rail and technical details.

2.2 Wheel-rail system

The employed wheel-rail system is a light rail in Brno, Czech Republic. For testing purposes, a curve with a radius of 200 m (parallel tracks with rail profile 49E1) was employed because of unpleasant railway noise and corrugation of both rails, see Fig. 2 where the complete track characteristics can be viewed. The off-board system for FM application is located near the curve and simultaneously far enough from the next station where the trams need to decelerate. The tram with four driven and braked wheel axles with axle load of 4 t was used. It should be noted that no adhesion control system was applied during tests.

2.3 Off-board system and friction modifier

The used wayside lubrication system is depicted in Fig. 3. This system allows to apply FM with lubricant viscosity class from NLGI-0 to NLGI-2. FM is applied on the top of the rail using the application strip and the high-pressure pumping device with working pressure of 250 bar. The entire lubrication process is activated by the vehicle-presence sensor which detects the individual tram axles. Based on the signal from this sensor, the control unit applies a dosage of FM. This system enables to set a duration of dosage and also a specific number of axles to pass before the system is activated. It should be emphasized that application bars (strips) are on both rails, see Fig. 3.

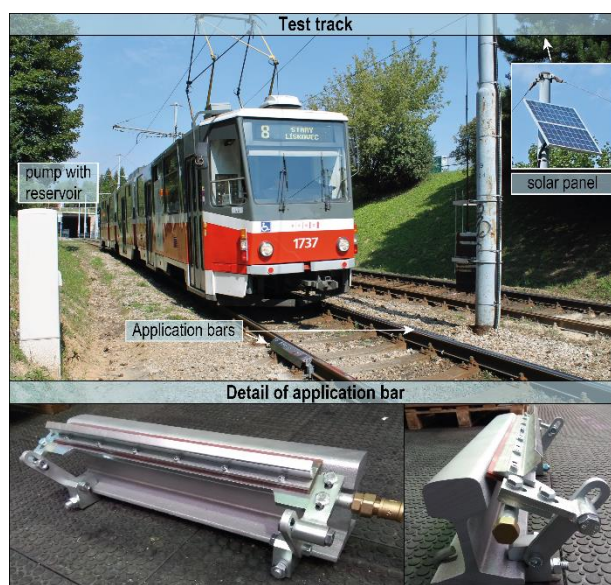

Fig. 3. Detail of new-developed off-board system.

In this study, the oil-based FM with NLGI number 1 was utilized. This FM contains plant oil, thickener, and Cu and Zn flakes with the predominant size in the range of 4-10 as was described in [10]. This range of particles is typical for the so-called High Positive Friction modifier (HPF) providing the intermediate level of adhesion and positive friction characteristic. This FM was chosen based on the suitable friction behaviour, particularly N-shape behaviour, which was found in the previous authors' study [10]. Another reason is the fact that this FM is already commonly used in Europe.

2.4 Experimental procedure

Laboratory tests

During laboratory experiments, the adhesion coefficient and level of noise were evaluated. All tests were carried out under the following conditions: contact pressure $p_h = 0.8$ GPa, mean speed $u_m = 1$ m/s, SRR = 0.08 and under ambient temperature $t_a = 23^\circ\text{C}$ and humidity of 40%. FM was applied on the disc using a micropipette which is able to apply liquid substances from minimum of 1 μl (error ± 0.04 μl). In this study, the effect of FM quantity was investigated for four quantities: 1, 2, 3 and 4 μl . The experimental procedure was as follows:

1. To reach the dry level of adhesion the run-in test was carried out.
2. Setup of required AoA. The value of AoA was 4° for all laboratory experiments in this study. This value is typical for reversing loops.
3. Application of given quantity of FM into the contact path on the disc.
4. Start of the main experiment with FM: adhesion and sound level measurements. The experiment was finished when the adhesion coefficient was recovered to the dry level of adhesion.
5. Ultrasonic cleaning of discs.

Field tests

Two different types of field tests were performed in this study. At first, the braking tests with various quantities of FM were conducted to evaluate the appropriate quantity in terms of the braking distance extension. Each braking test started in the station by acceleration of the tram to the required speed of 40 km/h. This speed has to be reached before the tram approaches the off-board system. Subsequently, when the off-board system is reached, the tram driver applies the maximal braking power and the braking distance is recorded. This represents the worst case scenario which can occur in real operation. Each braking test includes the following procedures:

1. Tests under baseline (dry) conditions. These tests were carried out three times in order to investigate the repeatability of experiment.

Based on these tests, an average value of braking distance under baseline conditions was calculated. Subsequently, this average value was used as a reference value for test with FM.

2. Application of given quantity of FM on the top of both rails. In this case, the sensor detecting the vehicle was not used because the tested quantity was always applied prior to the beginning of the experiment.
3. Tests with FM included several passes of the tram in order to determine the changes in braking distance. It should be noted that the tram went to the next station and back after each individual pass in order to spread FM all over the tested track.
4. Comparison of braking performances under baseline and FM conditions as is depicted in Fig. 7.

Once a braking test was completed, the off-board system was turned off for one week. This time period should ensure that almost all FMs were removed from rails by passing trams. After one week, points 1-4 were conducted again for another quantity of FM. In this study, three different quantities of FM were successively tested, specifically 1, 2 and 4 g. Manufacturer's recommended quantity of tested FM is approximately 2 g per 100 axles.

The second type of field tests dealt with the sound level measurements. These measurements were conducted for both baseline conditions (without FM) and the conditions with application of FM. For these measurements, only one quantity of FM was tested with respect to the results of braking tests. These measurements were conducted in real operating conditions.

Sound measurements

Sound level measurements were carried out using a hand-held analyser, Brüel & Kjær type 2270. During the laboratory experiments, the microphone of analyser was mounted 1 m above the floor (10 cm above the contact of discs) and 50 cm from the contact in the horizontal direction. Microphone was oriented towards the contact of discs. The sound level L_{AF} was evaluated from the application point to the

moment when the adhesion coefficient was recovered to the dry conditions.

During field tests, the analyser was placed 7.5 m from the centre of the track with the microphone of analyser 1.2 m above the ground. Each particular sound measurement took 10 seconds. This time period approximately represents the time of train in the curve. The sound measurements were made for 40 trams under both baseline conditions and the conditions with FM. A minimum L_{Aeqmin} , average L_{Aeqavg} and a maximum sound-level L_{Aeqmax} were evaluated during these measurements. With respect to the fact that the testing track is near the urban area, A-weighting was applied for all field and laboratory sound measurements.

3. RESULTS AND DISCUSSION

3.1 Laboratory tests

The adhesion measurements are collected in Fig. 4. During these measurements, the lasting effect and the time period when a critical adhesion occurs were evaluated. In this study, the lasting effect is considered as the time period between the application point and the moment when the adhesion coefficient reaches the value of 0.35 as is depicted in Fig. 4. Above this value, the effect of FM on adhesion as well as on the reduction of sound level is nearly negligible.

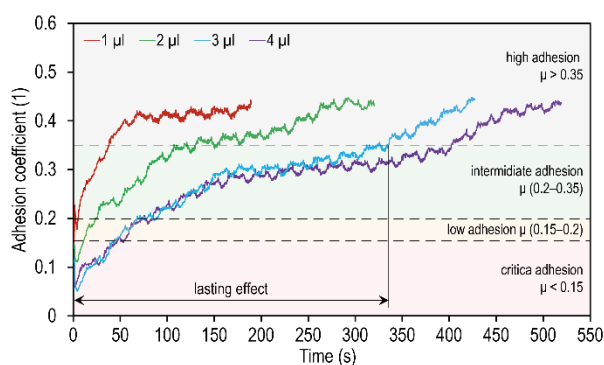

Fig. 4. Friction curves for various quantities of FM.

From Fig. 4, it is obvious that the lasting effect of FM extends with an increasing quantity of FM. A similar trend of friction curves, depending on the applied quantity, was previously found for both oil-based and water-based FM [10, 11]. In the present study, the results showed that the smaller quantities (1 and 2 μl) do not provide

the stable level of adhesion at the intermediate adhesion level, see Fig. 4. In these cases, the performance of FM is markedly affected by starvation of contact, which was described in detail in [14]. In contrast, the quantities 3 and 4 μl can be considered as the suitable quantities because they exhibit the so-called N-shape behaviour which was described in [15]. This behaviour is characterized by the stable part of adhesion after the initial adhesion. This N-shape behaviour extends the lasting effect of FM; thus, also the wear rate is also reduced. However, it should be emphasized that the quantities providing the N-shape behaviour (3 and 4 μl) cause a critical adhesion during the first 50 cycles after the application of FM, see Fig. 4. The tendency to poor adhesion conditions after the application of both water-based and oil-based FM was previously observed in both laboratory and real conditions [10, 11]. These adhesion losses can have a large impact on braking/traction performance; thus, the safety of railway transportation can be affected especially near the station or when climbing a slope.

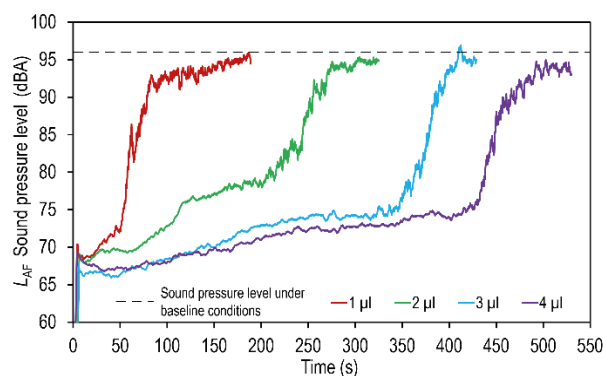

Fig. 5. Effect of FM quantities on sound level.

Sound level measurements showed that all tested quantities of FM reduce noise from 97 dBA (baseline conditions) to 64-68 dBA immediately after the application of FM, see Fig. 5. Subsequently, a gradual increase in adhesion and sound level pressure occurs when the adhesion coefficient reaches the high adhesion level ($\mu > 0.35$), see Fig. 6. Then, the slope of sound and friction curves was changed and a higher scatter of sound data was observed. Based on these experiments, it can be concluded that the quantities 2, 3 and 4 μl provide a significant noise reduction for tested conditions. In contrast, the effect of 1 μl seems to be almost insufficient for noise reduction because of the fast recovery of sound level pressure to baseline conditions.

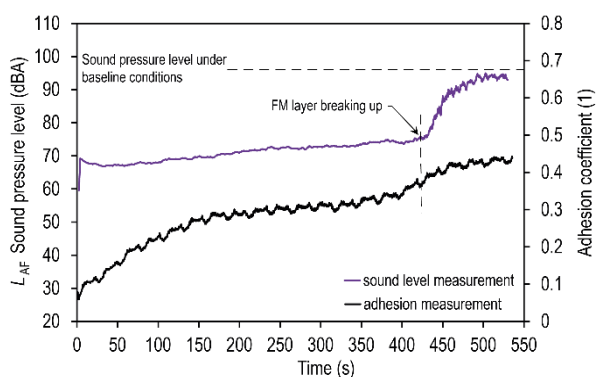

Fig. 6. Comparison of friction and sound pressure measurement.

These laboratory measurements show that the quantities exhibiting advantageous N-shape behaviour ensure a substantial decrease in sound level; moreover, a reduction of wear rate can be expected. On the other hand, the critical adhesion can easily occur during the first passes of the tram.

3.2 Field tests

With respect to the laboratory investigation, the experiments with various quantities (4, 2, 1 g/rail) were performed first to evaluate their impact on braking distance of the tram. The first braking test was conducted with 4 g of FM per single rail, see Fig. 7. This figure shows the change of tram braking distance for several consecutive tram passes. It is evident that the braking distance was considerably extended in all tram passes in comparison with baseline conditions. It should be noted that the longest braking distance was observed in the second and third tram pass while the braking distance closest to baseline conditions was found for the first pass after the application of FM. During the second and third pass, slide of wheel (complete wheels slip) occurred as a result of high quantity of FM on the rails. This slide of wheels has a negative impact on both contact bodies (flat spot, rail joints, etc.) and also on a brakes of vehicle as a result of high temperature between wheel and brake shoes [16, 17]. On the contrary, in the fourth pass, wheels slide was not detected but some wheels were still under slip. In the case of the following passes, no slip was observed; thus, the shorter braking distances were evaluated.

At the end of the braking test No.1, the spreading ability (carry distance) of FM over the rails was evaluated, see Fig. 8. From this figure, it is

evident that FM was found at the distance of 100 m from the application point, observed with naked eye. This observation suggests that if the reasonable quantity of FM is applied, the carry distance is rather limited compared to the previous published results where these distances reached several miles [18]. However, this shorter carry distance can be advantageous to light rail systems or metros because a braking performance of vehicle near the next station should not be already influenced.

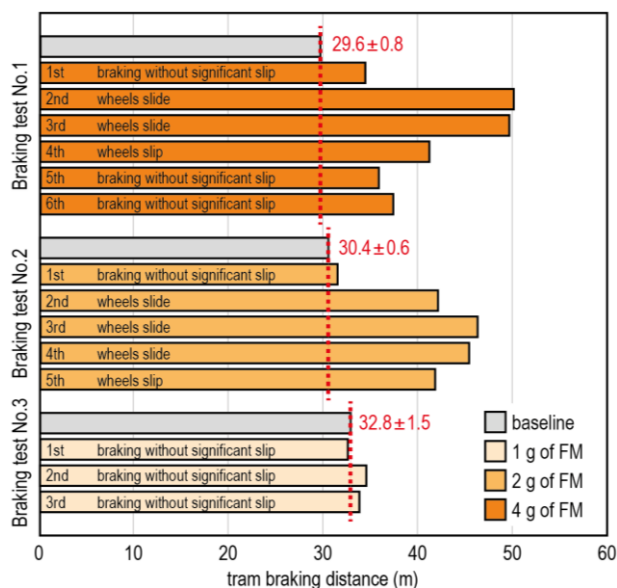

Fig. 7. Testing curve of tramway track and technical details.

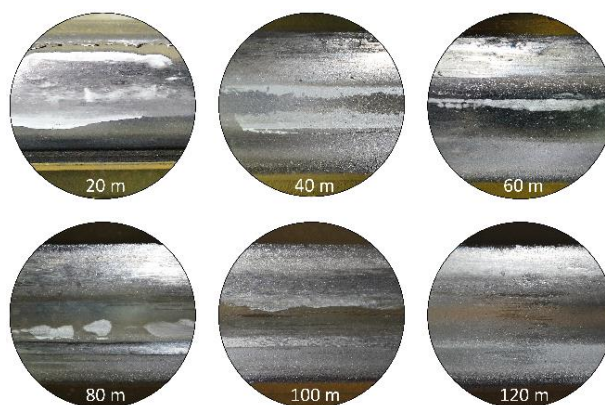

Fig. 8. The spreading ability of FM depending on the distance from the application point.

The braking test No.2 was conducted with 2 g of FM per single rail. The results showed that the trend of the braking distances was almost the same as in the braking test No.1. While the effect of FM on braking distance was almost negligible during the first pass, it became essential for the next three passes. It should be noted that the

braking distance started to decrease after the third pass although the slide of wheels occurred in the following two passes. It can be expected that if the next pass was carried out, the braking distance would be the shortest and simultaneously the slide of wheels would not occur as well as in the case of the braking test No.1.

The last braking test (No.3) was performed with FM quantity of 1 g/rail. The results showed that the extension of braking distances was negligible for all passes. Moreover, no slide of wheels was observed. It is apparent that the trend of braking distances was the same as in the previous braking test. It should be noted that the braking distance was even slightly shorter during the first pass with FM than under baseline conditions.

The above-mentioned braking tests give the evidence that the larger quantity of FM (4 and 2 g/rail) can endanger the safety of rail transportation especially during the second and third passes after the application of FM where inadequate long braking distances were found. On the contrary, in the first pass, the effect of FM on braking performance was not as significant as expected. This behaviour can be explained as follows: the FM film is formed on top-of-rails during the first pass. It means that the braking performance during the first pass is influenced both by FM and the braking ability of dry contact. Regarding the safe braking distance of tram, the quantity of 1 g/rail seems to be the optimal quantity (from among the tested quantities).

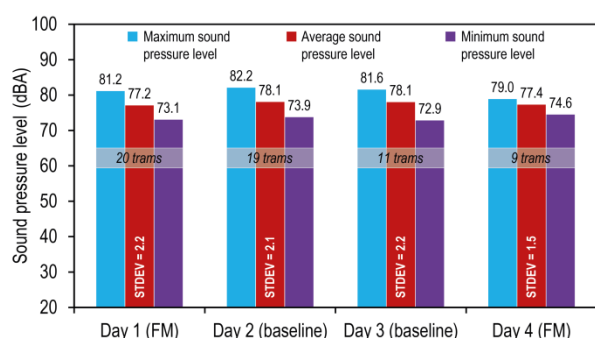

Fig. 9. Sound pressure measurement for contact with FM and for baseline conditions.

With regard to the braking tests, the quantity of 1 g/rail was selected as a suitable quantity in terms of braking distance for investigation of FM effect on noise. The quantity of 1g/rail of FM was

applied every 100 axles. As it is clear from Fig. 9, FM was applied on the day 1 and 4 whereas the experiments during the day 2 and 3 were carried out under baseline conditions (without FM).

Fig. 9 shows that there is no positive effect of FM on noise reduction in spite of the fact that FM was visible on the top-of-rails. These findings showed that the quantity of 1 g/rail appears to be inefficient in terms of noise reduction. This is in accordance with laboratory measurement with 1 μ l where the effect of FM on noise reduction was almost negligible because of rapid increase of sound level to baseline conditions. Other authors reported that water-based FM can reduce a squeal noise about 12 dB for tram/light rail system [2]. However, the effect of FM on adhesion or braking distance was not studied in [2]. It can be reasonably expected that the larger quantities used in this study (e.g. 4 g/rail) are able to considerably reduce noise as in the case of [2] but there is a significant impact on braking distance. Inability of FM to reduce noise can be explained by the absence of squeal noise on the test track. It suggests that FM is probably not able to reduce the other type of wheel/rail noise.

This study suggests that if the wheel-rail contact is overdosed by oil-based FM, the slide of wheels can occur; it results in significant impact on the length of the tram braking distance. Moreover, flat spots can be formed on wheels due to the wheel slide. This conclusion is in a good agreement with the previous field study conducted by Lundberg et al. [11]. They revealed that the adhesion coefficient was strongly dependent on the quantity of FM in the contact, and the application of large quantity of FM led to unacceptably low adhesion coefficients (on average 0.13-0.16). This decrease of adhesion can be catastrophic with respect to the length of braking distances. A similar drop of COF was observed in [9] where a hand-pushed tribometer in real railway system was used. In this case, COF was reduced to 0.15 and 0.13, depending on the contact pressure, when FM was applied. Beside the field tests, the laboratory experiments also show that oil-based FMs can cause adhesion losses after application of FM [10]. In [10], this behaviour was explained as an effort of metal particles to avoid the point contact under fully flooded conditions. However, considering that the width of the real contact area is several times larger compared to the ball-on-disc apparatus employed in [10], it can be

assumed that the metal particles enter the contact. Furthermore, the metal particles were identified on the top-of-rail surfaces after the braking test with high quantity of FM, see Fig. 8. In author's opinion, adhesions, as well as the braking distance, are controlled by the metal particles contained in FM only in the case of small quantity of FM. Provided that the quantity of FM is high, adhesion is controlled especially by the base oil and it results in poor adhesion conditions.

It should be noted that the results mentioned above do not correspond with the field study carried out by Yu et al. [18]. This study reported that FM has no negative impact on the train braking. However, FMs used in this research were water-based and petroleum-based. Moreover, a heavy haul freight train with many wagons was employed, so the operating conditions significantly varied. Based on this, it can be expected that the oil-based FM can cause a poor adhesion and wheels slide in an easier way than the water-based (drying FM) or petroleum-based FM. In addition, commuter trains and trams are probably more prone to wheels slide in comparison with heavy haul freight trains, as was reported in [19]. It should be noted that poor adhesion occurring immediately after the application of oil-based FM may be suppressed using the on-board system. In this case, FM is gradually sprayed over the rails thus avoiding an overdose of contact by FM.

4. CONCLUSION

The laboratory and field investigations focused on the effect of quantities of commercial oil-based FM on sound level and adhesion or tram braking distances have been presented in this paper.

The laboratory measurements showed that the larger quantities provide the significant noise reduction but critical adhesion occurs immediately after the application of FM. In contrast, smaller quantities are able to decrease both sound and adhesion without the risk of braking performance. However, these smaller quantities did not lead to the N-shape behaviour; thus, the lasting effect is rather limited.

In the case of field experiments, it was suggested that if the contact is overdosed by FM, then the braking distance can be significantly extended. The most critical passes were especially the second and third one after the application of FM which was accompanied by wheel slide. It means that under these conditions, the braking performance is significantly limited. It can be assumed that there is a limit for FM quantity below which the adhesion is mainly controlled by metal particles contained in FM, while above this quantity the adhesion is mainly given by the base medium. With regard to both laboratory and field results, the applied quantity appears as a crucial parameter for top-of-rail friction modification.

From laboratory and field investigations it is evident that it is quite difficult to achieve a reduction of sound level without the significant extension of braking distance as a result of critical adhesion.

The sound level measurements under real operating conditions showed that there is no positive effect of FM (1 g/rail) on noise reduction in spite of the fact that FM was visible on the top-of-rails.

Acknowledgement

The authors are sincerely grateful to European Commission for the financial sponsorship of the H2020-MSCA-RISE Project No. 691135 "RISEN: Rail Infrastructure Systems Engineering Network," which enables a global research network that tackles the grand challenge in railway infrastructure resilience and advanced sensing under extreme environments.

Authors would like to appreciate and thank for all the work and experiments done by Bc. Jiří Knápek during his study at the Brno University of Technology.

REFERENCES

- [1] J. Kalousek and K. Johnson, 'An investigation of short pitch wheel and rail corrugations on the Vancouver mass transit system', *Proceedings of the the Institution of Mechanical Engineers, Part F: Journal Of Rail And Rapid Transit*, vol. 206, no. 2, p. 206, 1992.

- [2] D.T. Eadie, M. Santoro and J. Kalousek, 'Railway noise and the effect of top of rail liquid friction modifiers: changes in sound and vibration spectral distributions in curves', *Wear*, vol. 258, no. 7-8, pp. 1148-1155, 2005.
- [3] J.I. Egana, J. Vinolas and N. Gil-Negrete, 'Effect of liquid high positive friction (HPF) modifier on wheel-rail contact and rail corrugation', *Tribology International*, vol. 38, no. 8, pp. 769-774, 2005.
- [4] D.T. Eadie, M. Santoro, K. Oldknow and Y. Oka, 'Field studies of the effect of friction modifiers on short pitch corrugation generation in curves', *Wear*, vol. 265, no. 9-10, pp. 1212-1221, 2008.
- [5] D.T. Eadie and M. Santoro, 'Top-of-rail friction control for curve noise mitigation and corrugation rate reduction', *Journal of Sound and Vibration*, vol. 293, no. 3-5, pp. 747-757, 2006.
- [6] M. Tomeoka, N. Kabe, M. Tanimoto, E. Miyauchi and M. Nakata, 'Friction control between wheel and rail by means of on-board lubrication', *Wear*, vol. 253, no. 1-2, pp. 124-129, 2002.
- [7] Y. Suda et al., 'Development of onboard friction control', *Wear*, vol. 258, no. 7-8, pp. 1109-1114, 2005.
- [8] D. Elvidge, R. Stock, C. Hardwick and K. Oldknow, 'The effect of freight train mounted TOR-FM on wheel life and defects', *The Third International Conference on Railway Technology: Research, Development and Maintenance*, Cagliari, Italy, 2016, p. 174.
- [9] Y.A. Areiza, S. I. Garces, J.F. Santa, G. Vargas and A. Toro, 'Field measurement of coefficient of friction in rails using a hand-pushed tribometer', *Tribology International*, vol. 82, pp. 274-279, 2015.
- [10] R. Galas, M. Omasta, I. Krupka and M. Hartl, 'Laboratory investigation of ability of oil-based friction modifiers to control adhesion at wheel-rail interface', *Wear*, vol. 368-369, pp. 230-238, 2016.
- [11] J. Lundberg, M. Rantatalo, C. Wanhainen, and J. Casselgren, 'Measurements of friction coefficients between rails lubricated with a friction modifier and the wheels of an IORE locomotive during real working conditions', *Wear*, vol. 324, pp. 109-117, 2015.
- [12] S. Kaewunruen, 'Monitoring of rail corrugation growth on sharp curves for track maintenance prioritisation', *The International Journal of Acoustics and Vibration*, in press.
- [13] O. Arias-Cuevas, Z. Li, R. Lewis and E. A. Gallardo-Hernandez, 'Rolling-sliding laboratory tests of friction modifiers in dry and wet wheel-rail contacts', *Wear*, vol. 268, no. 3-4, pp. 543-551, 2010.
- [14] D. Kostal, P. Sperka, I. Krupka and M. Hartl, 'Experimental comparison of the behavior between base oil and grease starvation based on inlet film thickness', *Tribology in Industry*, vol. 39, no. 1, pp. 110-119, 2017.
- [15] X. Lu, J. Cotter and D. T. Eadie, 'Laboratory study of the tribological properties of friction modifier thin films for friction control at the wheel/rail interface', *Wear*, vol. 259, pp. 1262-1269, 2005.
- [16] F. Elshukri and R. Lewis, 'An Experimental Investigation and Improvement of Insulated Rail Joints', *Tribology in Industry*, vol. 38, no. 1, pp. 121-126, 2016.
- [17] A. Tudor, C. Radulescu and I. Petre, 'Thermal Effect of the Brake Shoes Friction on the Wheel /Rail Contact', *Tribology in Industry*, vol. 25, no. 1&2, pp. 27-32, 2003.
- [18] M. Yu and P. Ray, 'Evaluation of two TOR products on river grade track', in *the AREMA Annual Conference*, Minneapolis, USA, 2015, p. 16.
- [19] R. Stock, L. Stanlake, C. Hardwick, M. Yu, D. Eadie and R. Lewis, 'Material concepts for top of rail friction management - Classification, characterisation and application', *Wear*, vol. 366-367, pp. 225-232, 2016.

NOMENCLATURE

Subscripts:

1	Relation to the wheel disc
2	Relation to the rail disc
AoA	Angle of attack
F_N	Normal force in the contact
F_T	Friction force in the contact
L_{AF}	A-weighted, Fast, Sound level
L_{Aeqmin}	A-weighted, Fast, Minimum, Equivalent sound level
L_{Aeqavg}	A-weighted, Fast, Average, Equivalent sound level
L_{Aeqmax}	A-weighted, Fast, Maximum, Equivalent sound level
$n_{1;2}$	Revolutions of discs
p_h	Hertzian pressure in the contact
$r_{1;2}$	Diameters of discs
SRR	Slide-to-roll ratio
t_a	Ambient temperature
$u_{1;2}$	Entrainment speeds of surfaces
u_m	Mean speed; $(u_1 + u_2)/2$
μ	Adhesion coefficient