

## Future of Electric Railways

Krastev, Ivan; Tricoli, Pietro; Hillmansen, Stuart; Chen, Minwu

DOI:

[10.1109/MELE.2016.2584998](https://doi.org/10.1109/MELE.2016.2584998)

License:

Other (please specify with Rights Statement)

*Document Version*

Peer reviewed version

*Citation for published version (Harvard):*

Krastev, I, Tricoli, P, Hillmansen, S & Chen, M 2016, 'Future of Electric Railways: Advanced Electrification Systems with Static Converters for ac Railways' *IEEE Electrification Magazine*, vol. 4, no. 3, pp. 6-14. <https://doi.org/10.1109/MELE.2016.2584998>

[Link to publication on Research at Birmingham portal](#)

### **Publisher Rights Statement:**

(c) 2016 IEEE. Personal use of this material is permitted. Permission from IEEE must be obtained for all other users, including reprinting/republishing this material for advertising or promotional purposes, creating new collective works for resale or redistribution to servers or lists, or reuse of any copyrighted components of this work in other works.

### **General rights**

Unless a licence is specified above, all rights (including copyright and moral rights) in this document are retained by the authors and/or the copyright holders. The express permission of the copyright holder must be obtained for any use of this material other than for purposes permitted by law.

- Users may freely distribute the URL that is used to identify this publication.
- Users may download and/or print one copy of the publication from the University of Birmingham research portal for the purpose of private study or non-commercial research.
- User may use extracts from the document in line with the concept of 'fair dealing' under the Copyright, Designs and Patents Act 1988 (?)
- Users may not further distribute the material nor use it for the purposes of commercial gain.

Where a licence is displayed above, please note the terms and conditions of the licence govern your use of this document.

When citing, please reference the published version.

### **Take down policy**

While the University of Birmingham exercises care and attention in making items available there are rare occasions when an item has been uploaded in error or has been deemed to be commercially or otherwise sensitive.

If you believe that this is the case for this document, please contact [UBIRA@lists.bham.ac.uk](mailto:UBIRA@lists.bham.ac.uk) providing details and we will remove access to the work immediately and investigate.

# Advanced Electrification Systems with Static Converters for AC Railways

*Ivan Krastev, Pietro Tricoli, IEEE, member, Stuart Hillmansen, and Minwu Chen*

## **1. Introduction**

Railways are a vital part of the world economy, transporting both goods and passengers. Freight trains transport large amounts of goods, while high speed trains are the fastest land passenger systems. At present, the majority of rail networks across the world are non-electrified. They run diesel powered trains that require refuelling stations and produce high noise levels and pollutant emissions. On the other hand, electrified railways have an electrified network that directly supplies electric locomotives by means of pantographs or conducting shoes. Since electric trains do not carry the energy source on board, they can be lighter and more powerful. However, electric railways have higher initial capital costs and higher maintenance costs and are, therefore, economically justified only if the traffic on the line is substantial.

Historically, tramways were first electrified with a low voltage DC supply ( $< 750$  V). The first electrified mainline used a three-phase AC supply with 2 overhead wires (the third wire was the running rails), which required a complex pantograph system. Therefore after World War I a simpler single-phase AC system, operating at 15 kV at  $16\frac{2}{3}$  Hz, was adopted in Switzerland initially and later on in Austria, Germany, Sweden and Norway. Other countries in Europe adopted instead DC networks operating at 1.5 kV and 3 kV, whereas electrified railways in North America adopted a frequency of 25 Hz. With advancements on high power converters, the type of supply became independent on the type of traction motors used for the trains and, hence, single-phase 25 kV at 50 Hz became a popular solution. The main advantage of 50 Hz is the simplicity of the feeder stations and lower transmission losses in comparison to 3 kV DC systems, as well as smaller on board transformers in comparison to 15 kV,  $16\frac{2}{3}$  Hz systems. The 25 kV, 50 Hz electrification systems spread across Asia and today is adopted in China and India.

Both DC and low frequency railway supplies in Central Europe and North America require frequency converters to get power from the public three-phase grid. Throughout the 20<sup>th</sup> century, these

converters were almost always of the rotary type, with a three-phase motor mechanically coupled to a single-phase generator with a different number of pole pairs, as Fig. 1 shows. The rotary converters are connected in parallel to the main rail frequency supply and automatically share the traction load. Rotary converters require maintenance, as they have moving parts and the low frequency of the rail supply causes mechanical oscillations of the motor-generator pair that need damping to extend service life.

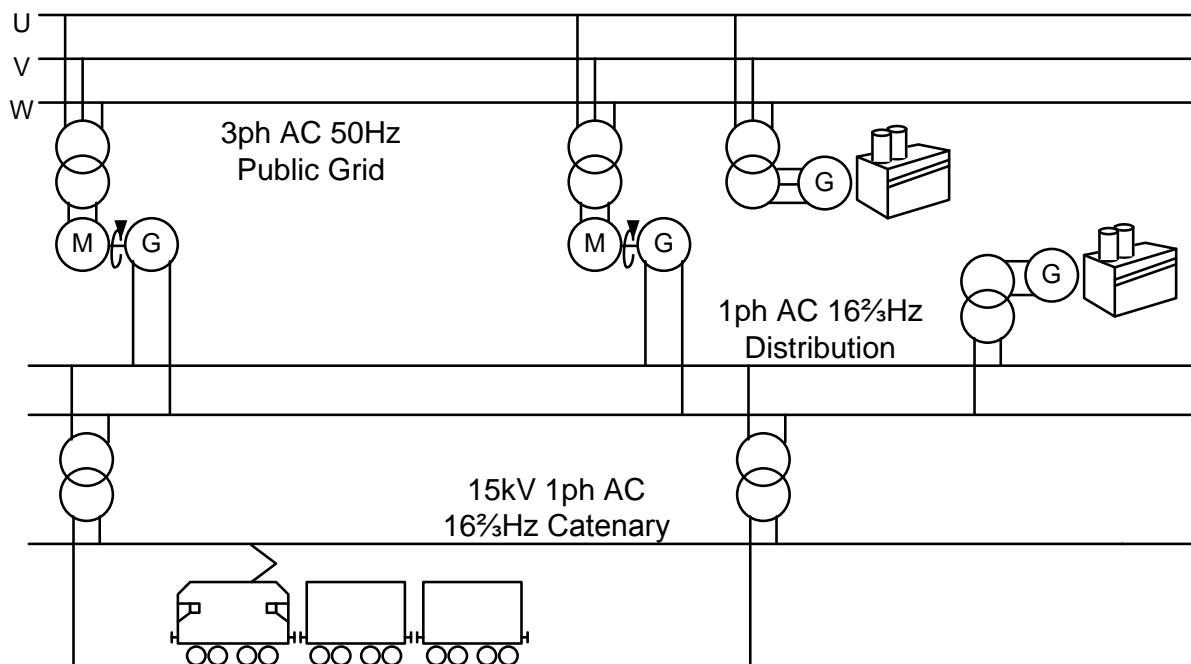

Figure 1. Typical railway supply network in Central Europe with mixed dedicated and non-dedicated power stations, M = motor, G = generator.

As power electronics devices were further developed in the 1980s and 1990s, cycloconverters with thyristors became a viable replacement of rotary converters. Cycloconverters can be fully controlled to regulate the voltage of the single-phase side, reducing the regulation effect due to train loads. However, the low switching frequency of thyristors requires large reactors to reduce the harmonic content of the output voltage waveform. Modern static frequency converters with IGBTs and GTOs switching at frequencies in the range of 1 kHz have been successfully deployed in Germany and Switzerland as a replacement of cycloconverters. They have active control and can strongly mitigate the effects on the public grid of non-linear traction loads.

As introduced before, frequency converters are not necessarily required for 25 kV, 50 Hz systems. The feeder stations are connected to high-voltage buses, generally operating at 400 kV or 132 kV, so that the railway load is a small fraction of the total power drawn from the bus bars and the imbalance of the single-phase load is negligible. The techniques to reduce the imbalance can be divided into passive and active methods. Passive solutions alternate the phase that supplies each section of the track, as Figure 2 shows. The major drawback of this solution is the requirement of neutral sections that ensure the electrical isolation between consecutive sections of the track. Special transformer connections, e.g. V-V, Le-Blanc or Scott can further reduce the imbalance, as Fig. 3 shows, but they are effective only for specific loading conditions.

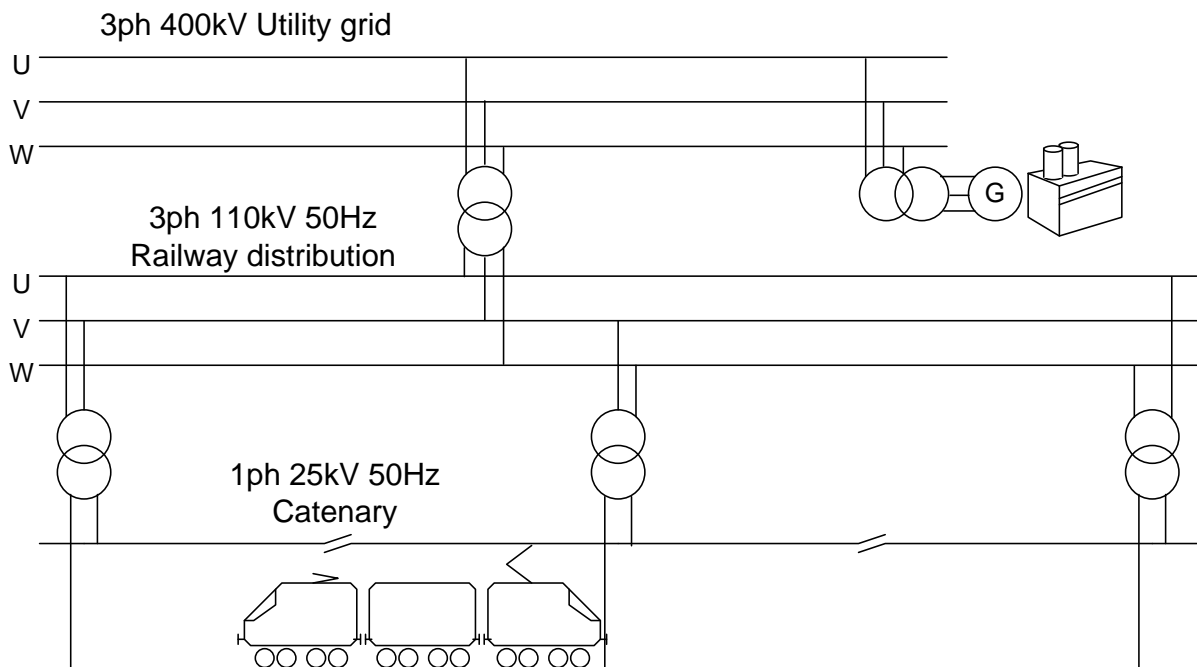

Figure 2 Connection of the 25kV, 50Hz railway supply to the public grid. Catenary is fed sequentially from each phase of the 3-phase distribution network

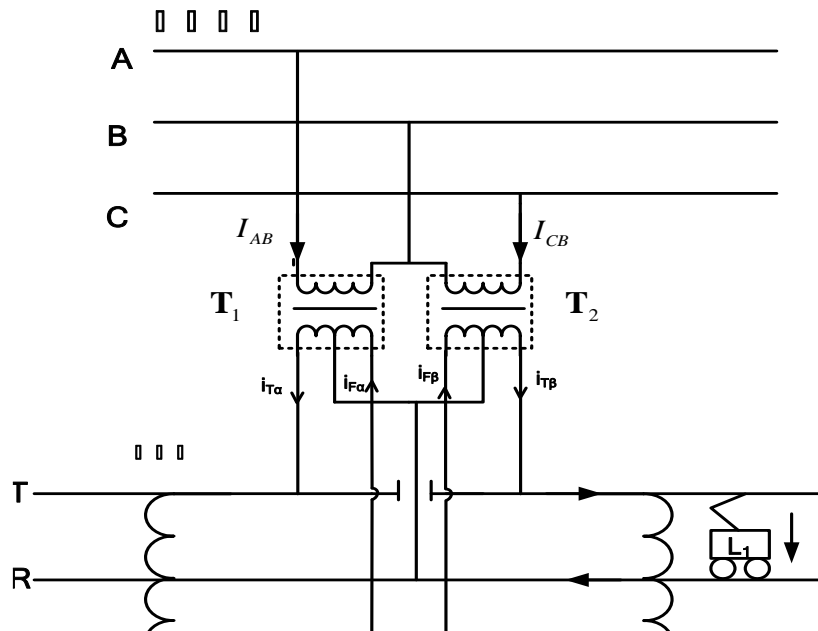

Figure 3 V-V transformer connection, with autotransformers, used in Japan and China

Active solutions use power electronics converters to reduce the imbalance and the voltage drop at the bus bars of the feeder stations. Static VAR compensators (SVCs) use thyristor controlled reactors (TCRs), and thyristor switched capacitors (TSCs). SVCs are well-established, but require large filters for the additional harmonics introduced by the thyristor switching. Alternatively, static synchronous compensators (STATCOMs) use switch-mode converters to compensate for the reactive power of single-phase transformers and to filter actively the harmonics produced by the railway loads, with passive filters relatively smaller than those required by SVCs. STATCOMs can be connected to the 3-phase grid or the single-phase overhead line and the topologies are based on conventional 2-levels or 3-levels H-bridges. In East Asia, STATCOMs are used in conjunction with V-V and Scott connected transformers as railway power conditioners (RPCs), as Fig. 4 shows. The converters are single-phase type and inject currents in parallel to the feeder transformers to balance the power drawn from the grid. Additional benefit of this system is that it can also have the function of an active power filter. Since the converter is connected between two consecutive phases of the main supply, the neutral sections of the overhead lines are still necessary.

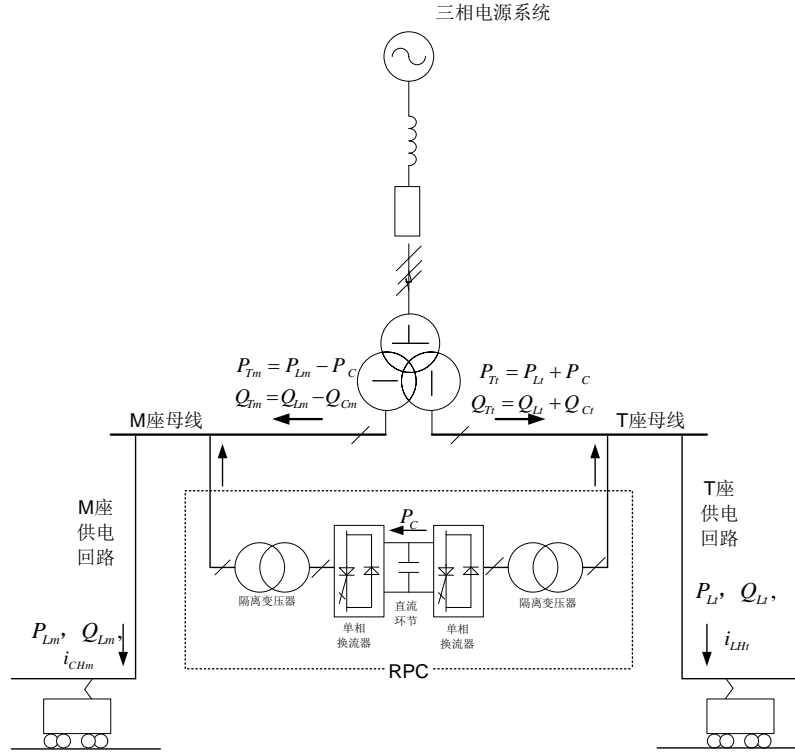

Figure 4 Traction power supply with railway power conditioner converter

## 2. Full converter solution

If the electrified line is supplied only by static frequency converters, they need to operate in all 4 quadrants and have power ratings adequate to supply the full power required by the trains. However, only little work has been done on static converters for 50 Hz railways, as the cost of active compensators like SVCs and STATCOMs is significantly smaller than that of full-size converters, since they have to be rated only for a fraction of the power of the feeder station. This view is changing nowadays, as new high-speed lines are being built in Europe and China, increasing power demand and thus the effect of railway imbalance on the utility grid. This is also further emphasised by the stricter regulations on imbalance introduced by the owners of the utility grid.

Feeder stations with full power converters draw a nearly sinusoidal balanced current at (nearly) unity power factor. Therefore, they are seen by the grid as a balanced 3-phase loads and can draw power from a lower voltage bus. This not only significantly reduces the cost of the connection of the feeder station to the utility grid in terms of equipment, e.g. cheaper switchgear and measurement transformers, but also simplifies significantly the location of the feeder stations on the railway line, as very often this is strictly related to the location of the high-voltage transmission lines. As the

converter has fully controlled currents on the 3-phase side, and regulated voltage on the single-phase side, the utility grid can be fully isolated from nonlinear traction loads, like legacy locomotives that use diode or thyristor rectifiers. The control of the voltage on the single-phase side also allows the synchronisation of the output voltages of multiple converters, thus creating a continuous overhead line without neutral sections.

Since the output voltage is regulated, the effect of the transformer output impedance can be mitigated. Moreover, the output current is also monitored, which means that the converter can implement any desired short circuit management scheme, with much reduced short circuit current and consequently switchgear rating.

As the overhead line can be continuous, the electrified network would be similar to a DC railway, where multiple substations provide power simultaneously to the trains, as Fig. 5 shows. Unlike DC railways, which have only the voltage magnitude as a degree of freedom to share the power, AC networks have two degrees of freedom, the voltage magnitude and phase angle. Therefore, active and reactive power sharing could be implemented for AC railways. Droop control is a control method for interconnecting multiple voltage-source inverters for microgrids operating in isolation from a stiff main grid. The control system is suitable for both unidirectional power sources, like photovoltaic generators, as well as bidirectional sources, like battery storage systems. With a droop controller each converter's frequency is a function of the active power, while the rms output voltage is a function of the reactive power, as Fig. 6 shows.

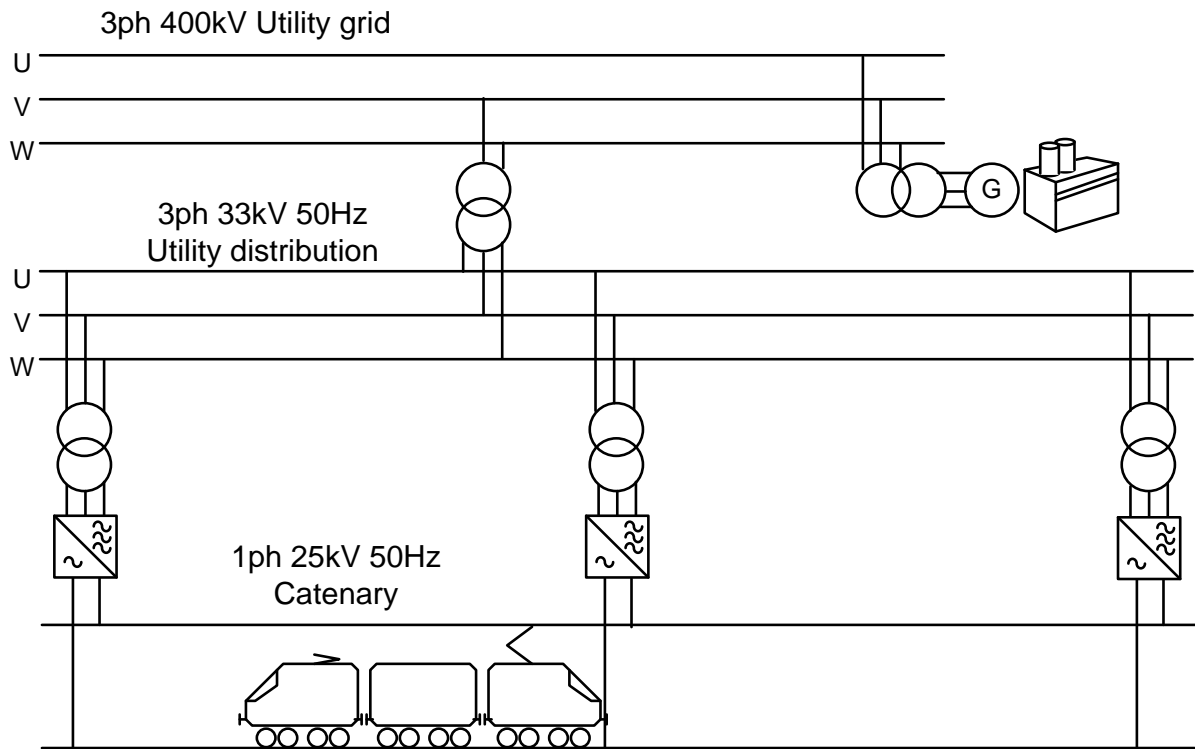

Figure 5 Concept of static converter railway supply without neutral sections

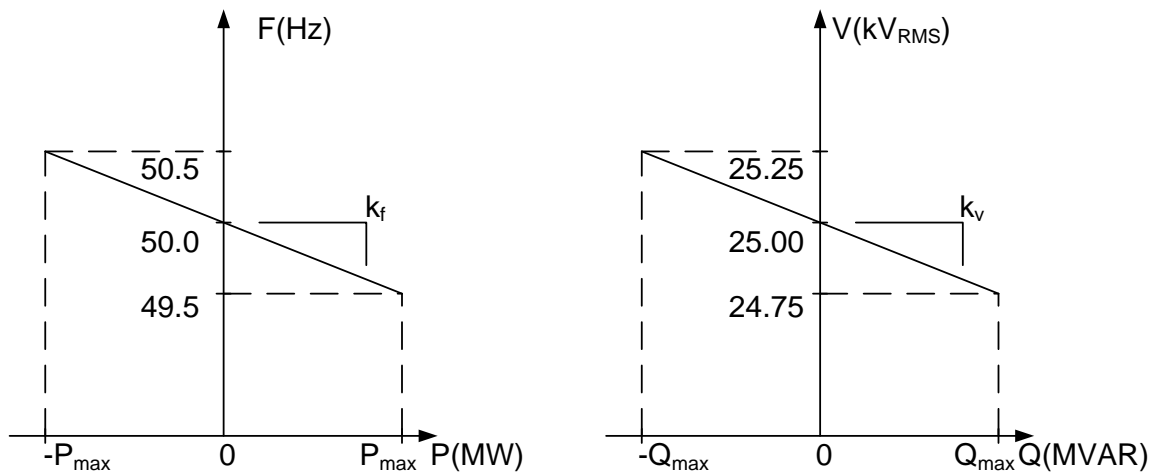

Figure 6 Example of frequency and voltage amplitude control for a droop controlled static converter station

The principle of a droop controller for a single-phase railway is illustrated with the simple simulation of Figure 7, with one train travelling on a railway fed by three static converters, spaced at 50 km each other. All converters have active output voltage control and are modelled as ideal voltage sources, supposing that the static converters are ideal within voltage and current ratings of the feeder station. The train load is represented by a current source working at the node frequency, which is representative of an ideal active front-end converter on board of the train. For short simulation times, the train can be assumed stationary, as at 200 km/h the train would travel only 0.5 km in 10 s, which



is 1% of the distance between the feeder stations. The results of the simulations are shown in Figure 8 for a train placed at 17.5 km from feeder station 1, although the particular position of the train is not relevant.

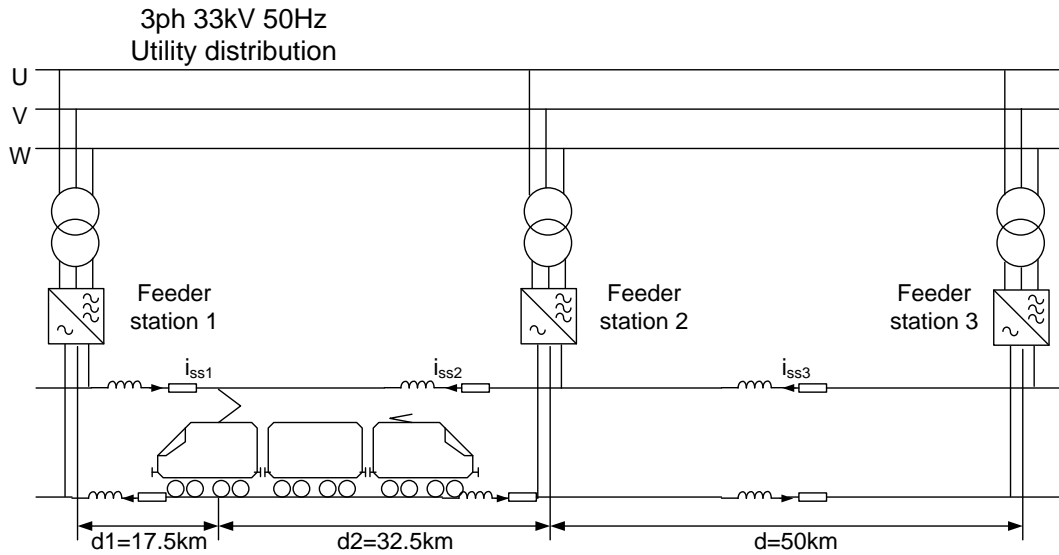

Figure 7 Train load supplied by 3 feeder stations with droop control with line impedances in evidence

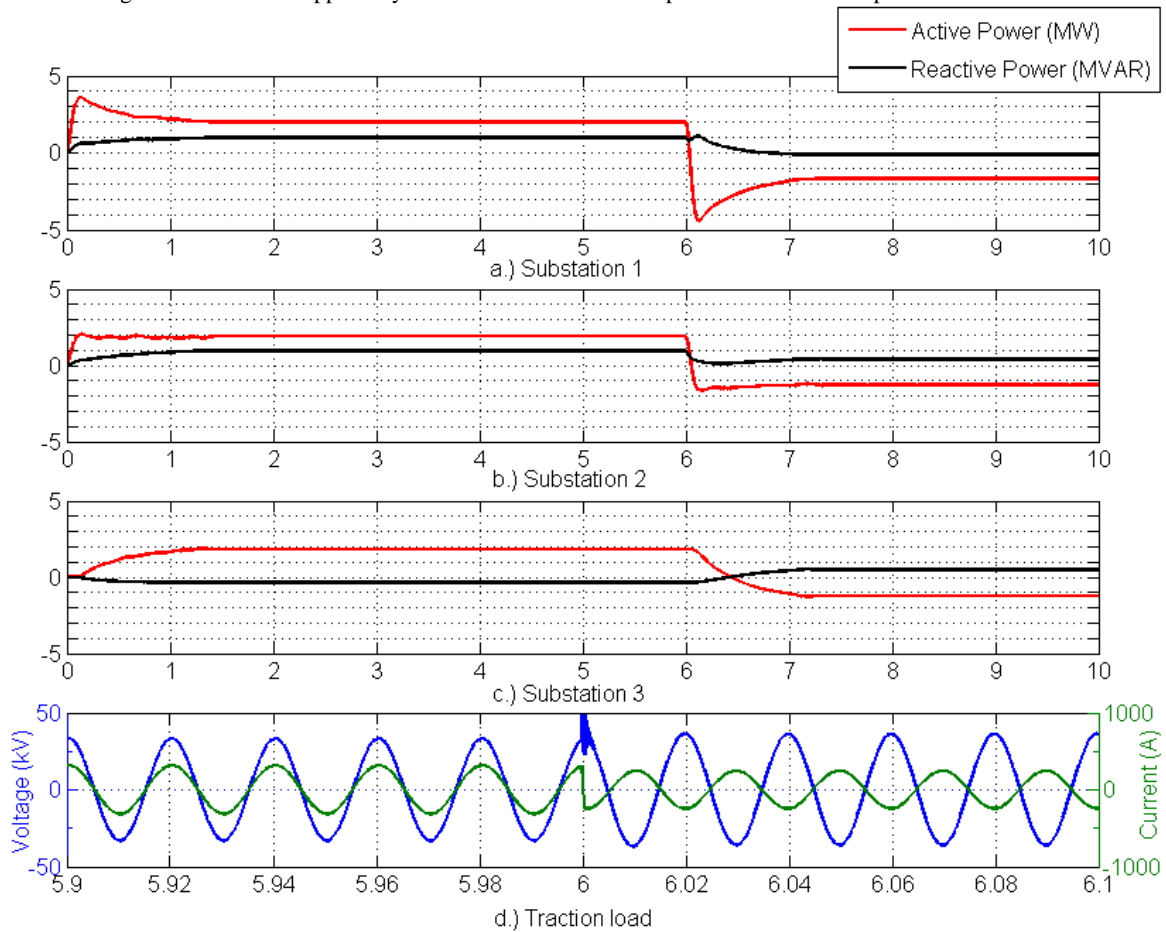

Figure 8 Three substations with droop control sourcing and sinking load power.

The line impedance has resistance of  $0.2 \Omega/\text{km}$  and reactance of  $0.7 \Omega/\text{km}$  at 50 Hz. The simulation shows that all substations share active power almost equally, with the one closest to the load (number 1) providing the peak during the transient. Even at a relatively long distance (87.5 km) the third station is providing power. Since the load is purely resistive and the line is mostly inductive, the reactive power of each station is expected to be slightly different. Thus only active power can be shared. Initial simulations look promising and further investigation is required for a full description of droop control performance of a single-phase electrified network. The main benefit of this scheme is that no communication, or external synchronisation, is required between different converters.

The majority of power converter topologies, for static converter substations, are based on voltage-source inverters, converting the 3-phase AC voltage to DC and then to single-phase AC. DC-link voltages can be up to 3.25 kV for 2-level H-bridges, using 6.5 kV IGBTs, and up to 6.5 kV for 3-level neutral-point clamped (NPC) bridges, as shown in Fig. 9. Since the catenary is 25 kV rms a single-phase output transformer is required for most converter topologies.

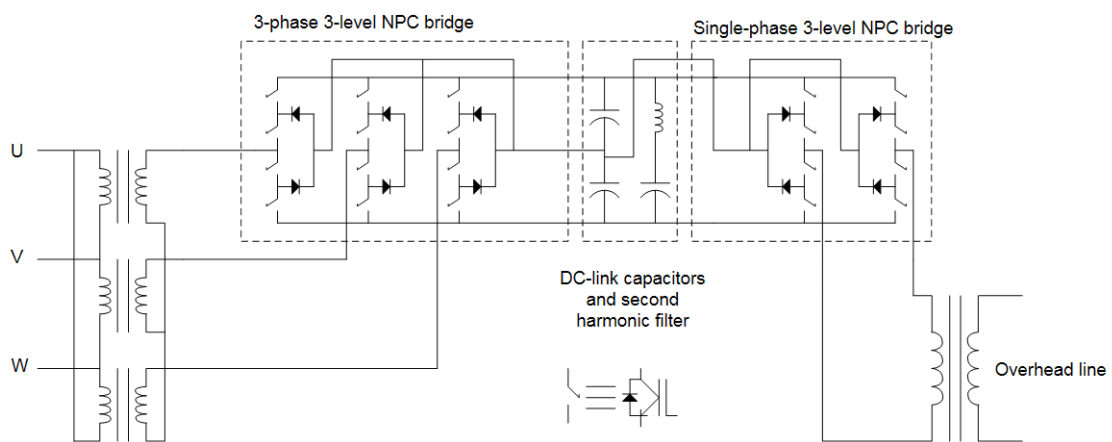

Figure 9 Detailed structure of a back-to-back converter, with one 3-phase and one single-phase bridge.

To increase the power of the converter, as well as the power quality, the 3-phase side is connected through a three-winding Ddy transformer, using two 3-phase bridges. On the single-phase side, multiple H-bridges are connected in parallel via a multiple winding transformer, as shown in Fig. 10. This transformer has the secondary windings connected in series to reach the required voltage of the overhead line. To reduce the distortion of the single-phase current, the PWM carriers of the single-phase converters are normally interleaved.

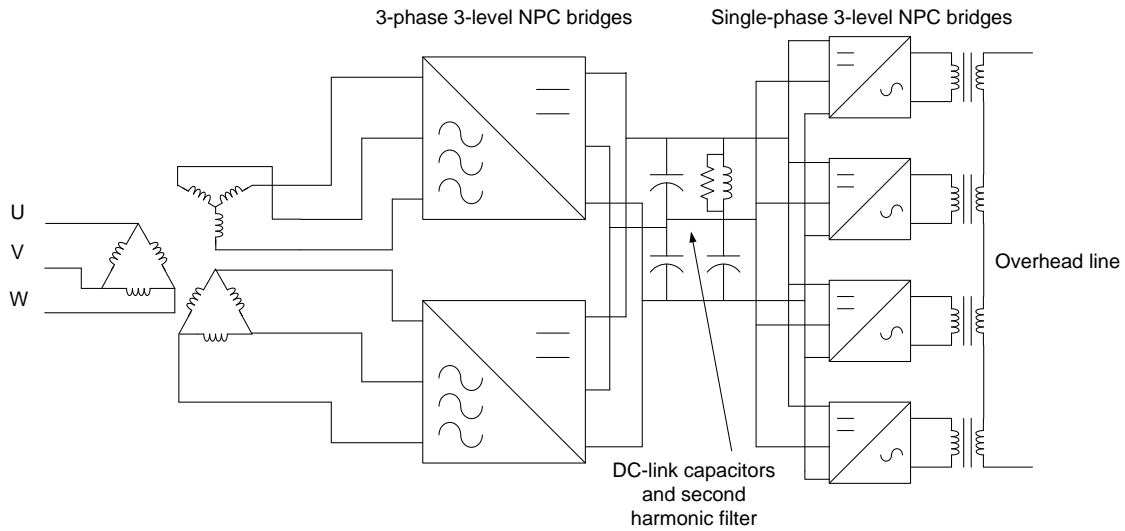

Figure 10 High-power back-to-back converter with a single DC-link

The back-to-back converter has limited fault tolerance. If one of the DC-link capacitors fails, the converter cannot be operated. The same applies to a short circuit fault in any of the transistors of the H-bridges, as the converter can still remain in operation only with open circuit faults.

Another topology is based on a single-phase cascaded H-bridge converter and has multiple DC-links, shown in Fig. 11. This topology is essentially formed by multiple back-to-back converter modules with 3-phase side in parallel and single-phase side in series.

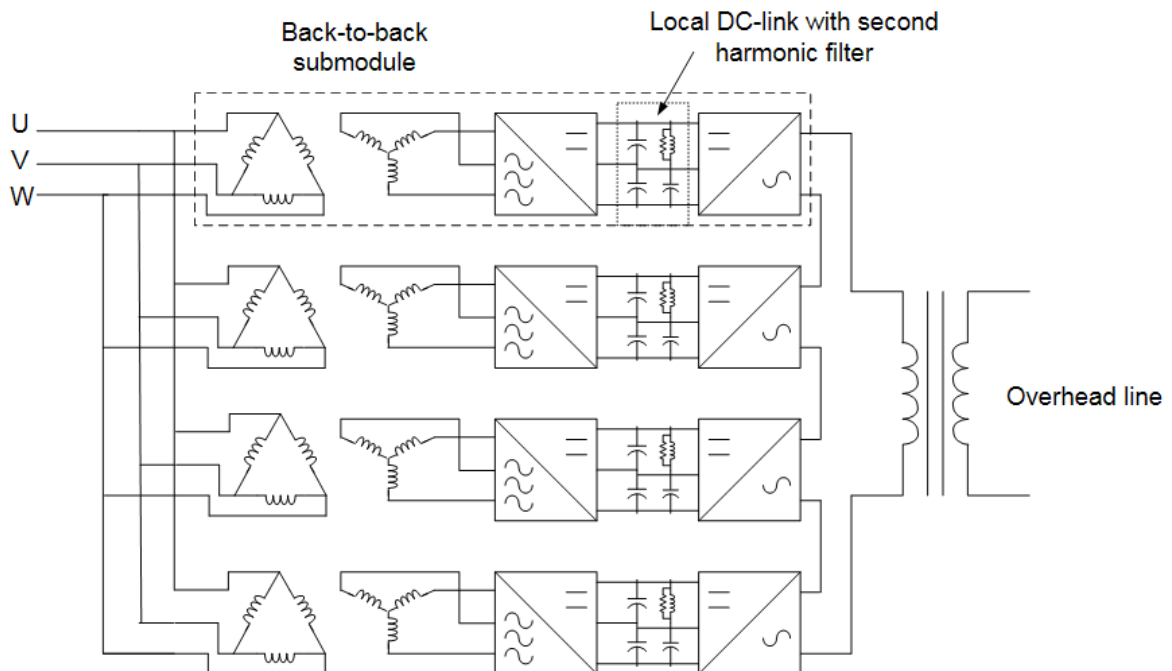

Figure 11 Multiple DC-link converter layout

The multiple DC-link converter has an output waveform better than that of the back-to-back converter and has better fault tolerance. Since all the single-phase bridges are in series, the output waveform is formed by several levels, drastically reducing the total harmonic distortion (THD) of the overhead voltage and the need of filters. In case of a fault of one of the H-bridges, the faulty module can be bypassed maintaining operations if the remaining modules can cope with the increase of their individual voltage. If enough modules are used, the single-phase transformer can be potentially omitted, reducing the cost of the converter.

A topology that was first utilised for high-voltage DC transmission lines is the modular multilevel converter (MMC). It is formed by arms where half-bridge or full-bridge submodules, with a flying capacitor, are series connected. Each arm has a reactor to smooth the current waveforms. The biggest benefit of this topology is its modularity and ability to work with high voltages. If  $n$  modules are connected in series, the effective switching frequency for each arm is  $n$ -times higher than the device switching frequency. This topology is similar to the multiple DC-link converter, with the key difference that both the 3-phase and single-phase sides have multilevel waveforms. The number of modules is chosen to give the desired rms voltage of the overhead line. For example a 15 kV overhead line voltage, i.e.  $\sim 21$  kV, could be obtained with 7 modules per arm, with flying capacitor voltage of 3.25 kV using 6.5 kV IGBTs.

Two MMC configurations are suitable for railway static converters: the direct AC/AC and the indirect AC/DC/AC type, shown in Figure 12 and Figure 13 respectively. The direct converter uses full-bridge modules that have positive and negative output voltage. Under normal operations, the converter circulates power between the three arms to compensate for the pulsating power on the overhead line side. The circulated power has two frequencies, the sum and the difference frequency between the 3-phase and the single-phase side. This imposes a limitation on the direct 3-phase to 1-phase converter as it requires a frequency separation. If the input and output frequencies are the same, no energy can be circulated between converter arms. This converter is well suited for low-frequency railways, as the circulating power difference frequency is higher than the catenary frequency, which reduces filter requirements.

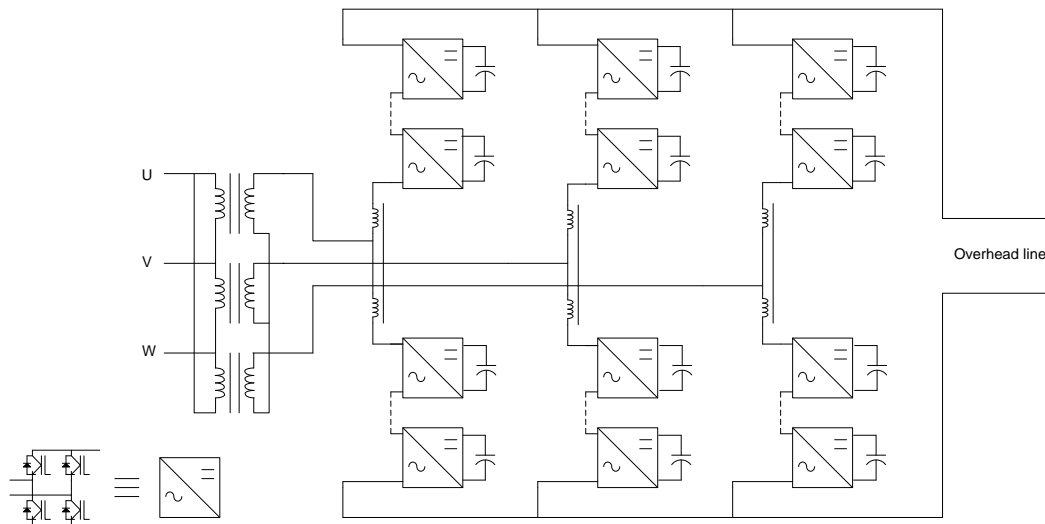

Figure 12 Direct AC/AC Modular Multilevel Converter for a 15 kV, 16.67 Hz substation

The indirect AC/DC/AC converter is formed by two cascaded MMCs. They use half-bridge modules and are connected by a DC-link, but this DC link does not have any capacitor. This topology has no limitation on frequency separation, so it can be used also when the input and output frequencies are the same. This converter is the only choice for 50 Hz railway supplies. For a 16.67 Hz supply, it would require larger floating capacitors and higher current rating devices for its single-phase in comparison to the direct MMC converter.

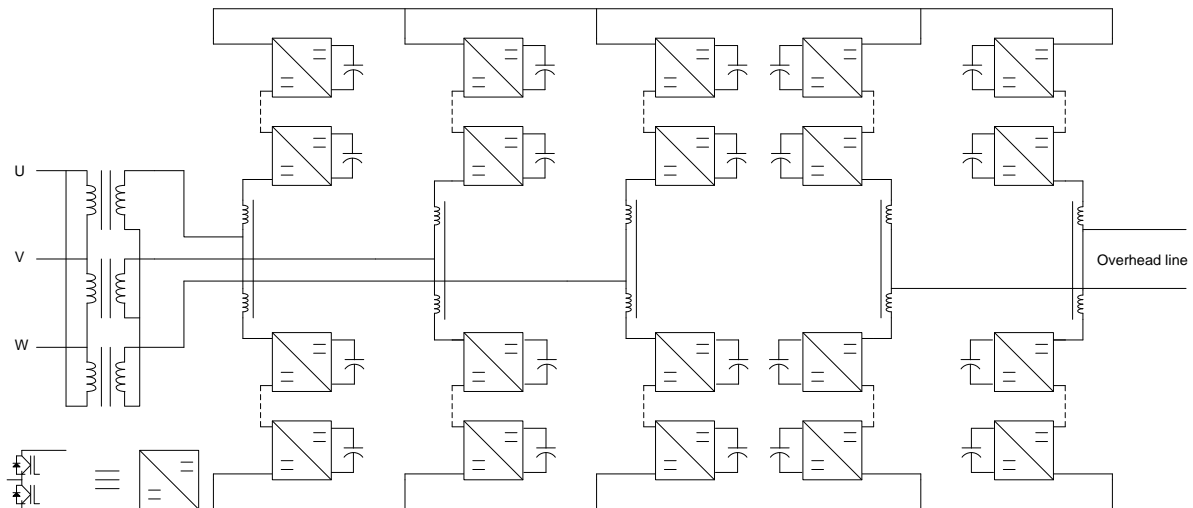

Figure 13 Indirect AC/DC/AC Modular Multilevel converter for 25 kV, 50 Hz substation

One important difference between the three converter topologies is the output voltage waveform, as it has a strong effect on required passive filters. The effect of the voltage waveform on current quality is shown in Figure 14. For these simulations, the device switching frequency and load inductance is the same. The waveforms are for converters using 3.25 kV nominal DC-link voltages and 6.5 kV IGBTs.

The MMC has the best quality of the voltage, although it requires the largest number of modules. The multiple DC-link converter would have the same quality of the output choosing half the number of modules equal to that of a MMC. It is important to note that these considerations are valid with the current availability of semiconductor devices. However, the new generation of wide band-gap devices might change substantially the present state of the art enabling a simpler design of medium-voltage converters without transformers and, hence, with higher efficiencies and lower costs.

The shape of the waveforms of the 3-phase side current for the back-to-back and multiple DC-link converter is identical to those represented in Figure 14 b), while for the MMC they are identical to those represented in Figure 14 a). A comparison between the three converter topologies is summarised in Table I, where  $n$  is the number of submodules of the converter.

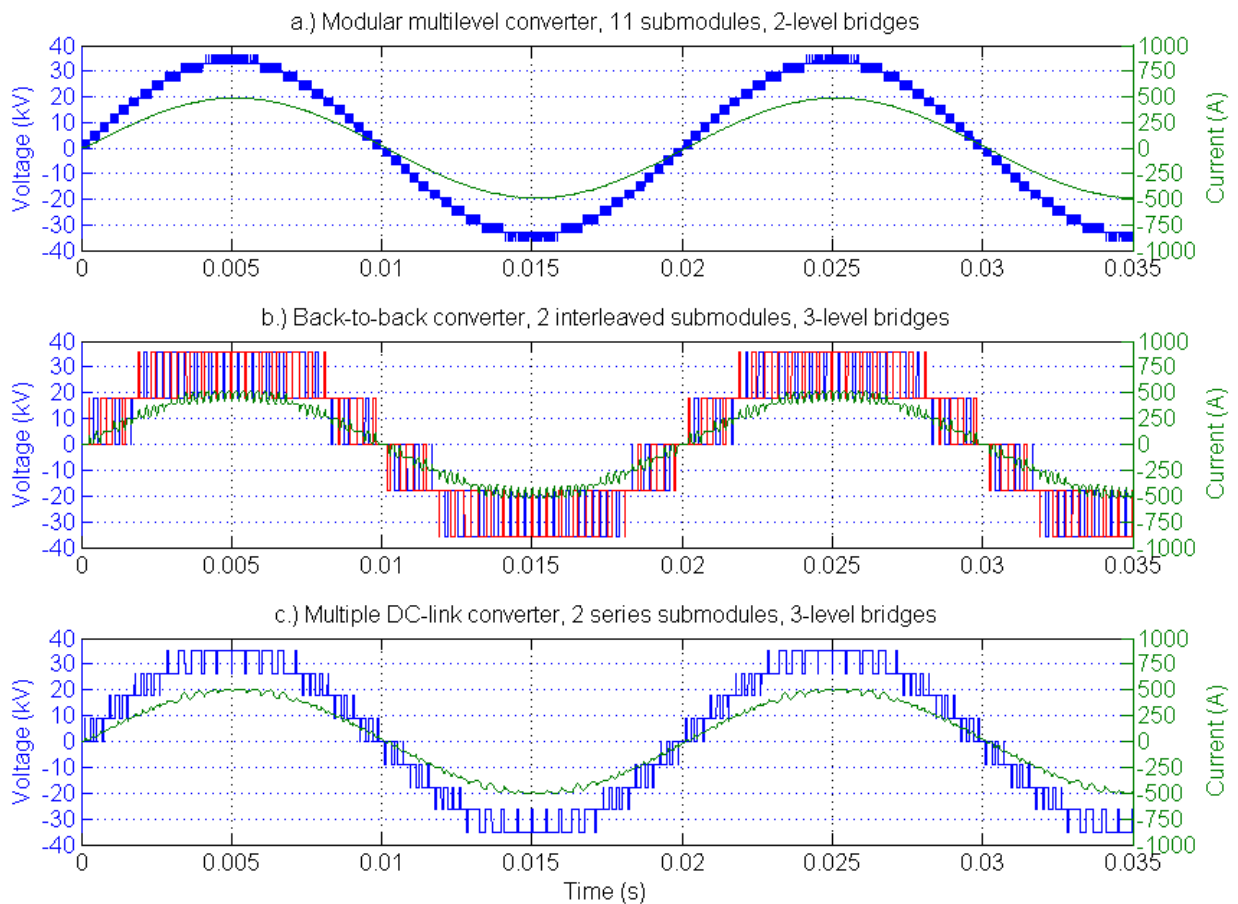

Figure 14 Comparison between different converter types feeding a passive load with 0.05 p.u. inductance. Only the modular multilevel converter doesn't use an output transformer.

Table I. Comparison between different converter topologies for static frequency converters

Converter type		Number of submodules per unit	Number of capacitors per unit	3-phase side waveform levels	Single-phase side waveform levels	Number of transformers required	Effective switching frequency
Modular Multilevel Converter	Direct	$6 \times n$	$6 \times n$	$n + 1$	$n + 1$	2 or 1 for high $n$	$n \times f_{device}$
	Indirect	$10 \times n$	$10 \times n$				
Back-to-back converter		$2 + n$	2	3	3	2	$2 \times f_{device}$
Multiple DC-link converter		$n$	$2 \times n$	3	$3 \times n$	$n + 1$ or $n$ for high $n$	$2 \times n \times f_{device}$

### 3. Co-phase and advanced co-phase system

An alternative electrification system, called co-phase power supply, is a hybrid solution between a STATCOM and a full static converter. It uses a static single-phase to single-phase power converter and an impedance matching  $Y_{nvd}$  transformer, which acts as a three-phase to two-phase converter. The winding ratio is chosen such that the three-phase side load is balanced when the currents on the secondary have equal magnitude and  $90^\circ$  phase shift. Thus, the aim of the control system is to inject the appropriate current to filter harmonics and reduce the negative sequence on the three-phase supply. Unlike STATCOMS, the converter of the co-phase supply can also supply active power directly to the load.

The setup in Figure 15 shows a co-phase substation feeding a single section of the track. The power is shared evenly between Phase A and the static converter. The circuit can be modified as a two-way system by connecting Phase B to a neighbouring track section and adding a neutral section between Phase A and Phase B. Therefore, the same converter could balance two track sections simultaneously reducing the cost of the installation. At present, a prototype feeder station has been built and tested showing improvement on the power quality of the supply.

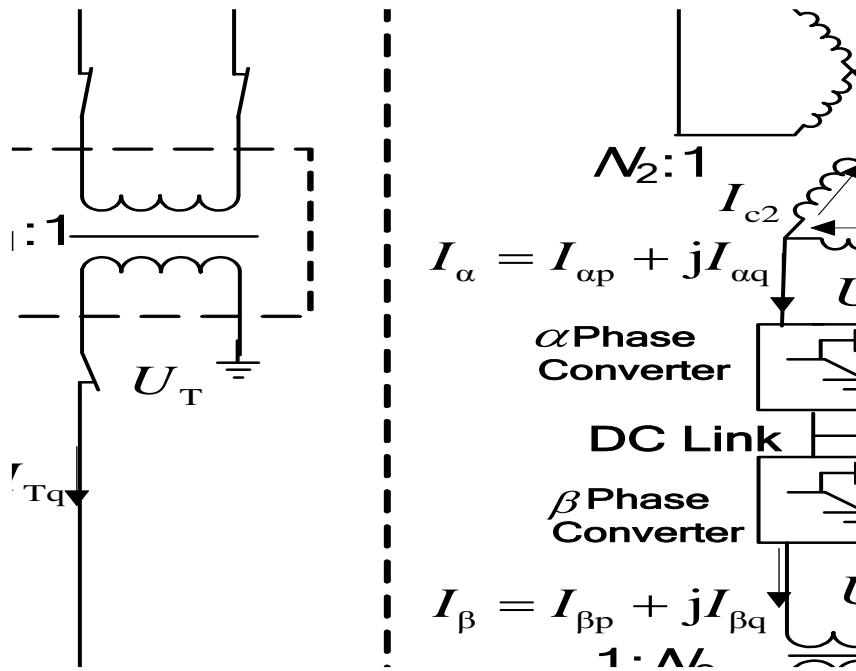

Figure 15 Co-phase power supply

The co-phase system has been further improved into the advanced co-phase power supply. The advanced co-phase supply replaces the Ynvd transformer with one single-phase and one three-phase transformer, as Fig. 16 shows. As the static converter is connected directly to one phase of the delta-connected winding, one single-phase transformer is saved, thus reducing cost and increasing efficiency.

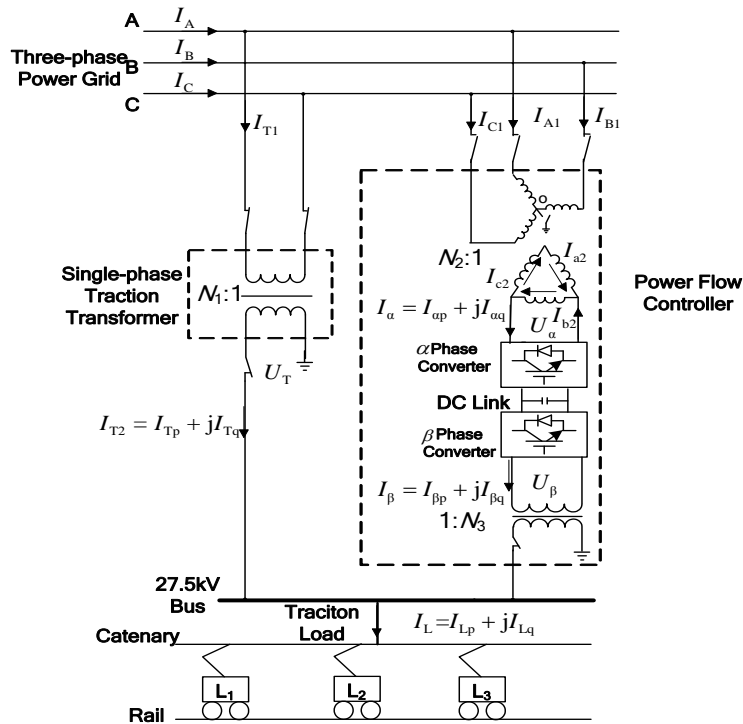

Figure 16 New advanced co-phase power supply



Since the co-phase power supply can maintain load balance on the three-phase side, the traction transformers of neighbouring stations can be connected to the same phase. There is a potential for complete omission of neutral sections, but the effect of variations along the line is still not completely understood. As the converter is bidirectional, some form of communication between the feeder stations will be required to avoid power circulation in parallel to the three-phase utility grid. In addition, the converter has limited control over the magnitude of the catenary voltage with injection of current from the  $\beta$  Phase converter, and no control over the angle of the catenary voltage, with consequent impossibility of power sharing methods like droop control. However, the control over the angle of the catenary voltage would be possible if the  $\beta$  Phase converter would be series connected to the main transformer rather than parallel connected.

#### **4. Discussion**

All railway power supply solutions presented have examples of field implementation. The comparison between the different solutions is summarised in Table II.

SVCs are an established technology but they need very large passive components and operate at low device switching frequency, which necessitates large filters. STATCOMs operate as active power filters, but require an additional transformer due to the low voltage ratings of IGBTs and GTOs. The main advantage of SVCs and STATCOMs is that they can be retrofitted to existing substations with minimal interruption of the service.

Full static converter feeder stations offer the best performance. While they are the most effective solution when frequency conversion is required, they are associated with high cost for 50 Hz or 60 Hz railway lines. However they do not require supply from a dedicated high-voltage transmission line and can be connected to the public grid without introducing load imbalance or significant harmonics. This can be translated in savings in terms of land, as well as auxiliary equipment and switchgear rated for lower voltage. This makes them more attractive for new railways, rather than for retrofitting existing feeder stations.

Co-phase power supplies have performance similar to STATCOMs, but have the possibility of omitting neutral sections between consecutive parts of track and require a smaller power rating for the

full compensation of the negative sequence of the input current. Similarly to STATCOMs and SVCs, the co-phase supply can be retrofitted easily as it can be added in parallel to existing transformers.

Table II. Comparison between different feeding systems of AC railways.

Power supply type	Converter power rating, p.u. of load	Neutral sections	Catenary voltage and frequency regulation	Harmonic compensation	Catenary short circuit protection	Passive filter size
SVC	0.58	Compulsory	None	No	Passive	Large
STATCOM	0.58	Compulsory	None	Yes	Passive	Small
Full converter	1.0	Can be omitted	Yes	Yes	Active	Small to none
Co-phase supply	0.5	Can be omitted	Yes	Yes	Passive	Small

Another factor to consider is that the regulations on grid imbalance vary across different Countries and full negative sequence compensation is not always required. SVC, STATCOM, and the co-phase converter ratings can be optimised to meet only regulation standards, which will reduce the cost of the installation. In contrast, the full converter solution has to be rated for the full traction load, but does not require the same design for conventional short-circuit levels, as it can have much smaller fault levels due to the controllability of the voltage on the overhead line side. Moreover, the large flexibility on the power control offered by static converters is a key factor for the introduction in the near future of smart railways, where electric railways will be fully integrated in the power system and help improve its operations, by integrating storage devices, contributing to the voltage and frequency regulation and optimising the use of electrical power for trains.

## 5. Further reading

1. N. Lang, "Electrifying History", *ABB Review Corporate Journal*, issue 2, pp. 88-94, 2010.
2. J.A.P. Lopes, C.L. Moreira, and A.G. Madureira, "Defining control strategies for MicroGrids islanded operation", *IEEE Trans. Power Sys.*, vol. 21, no. 2, pp. 916-924, 2006.
3. Y. Horita, et al., "Single-phase STATCOM for feeding system of Tokaido Shinkansen", in *2010 Int. Proc. Power Electron. Conf.*, 2010.

4. H. Wang, et al., "Analysis of static VAr compensators installed in different positions in electric railways", *IET Electr. Sys. in Transportation*, vol. 5, no. 3, pp. 129-134, 2015.
5. Y. Horita, et al., "Single-phase STATCOM for feeding system of Tokaido Shinkansen", in *2010 Int. Proc. Power Electron. Conf.*, 2010.
6. J. Ranneberg, "Transformerless topologies for future stationary AC-railway power supply", in *Proc. 2007 Eur. Conf. on Power Electron. and Appl.*, 2007.
7. M. Winkelkemper, A. Korn, and P. Steimer, "A modular direct converter for transformerless rail interties", in *Proc. 2010 IEEE Int. Symp. on Ind. Electron. ISIE 2010*, 2010.
8. Z. Shu, S. Xie, and Q. Li, "Single-Phase back-to-back converter for active power balancing, reactive power compensation, and harmonic filtering in traction power system", *IEEE Trans. Power Electron.*, vol. 26, no. 2, p. 334-343, 2011.
9. M. Chen, et al., "Modelling and performance analysis of advanced combined co-phase traction power supply system in electrified railway", *IET Gen., Transm. & Distrib.*, vol. 10, no. 4, pp. 906-916, 2016.