

## Direct contact between dust and HBCD-treated fabrics is an important pathway of source-to-dust transfer

Rauert, Cassandra; Kuribara, Isamu; Kataoka, Toshiyuki; Wada, Takeharu; Kajiwara, Natsuko; Suzuki, Go; Takigami, Hidetaka; Harrad, Stuart

DOI:

[10.1016/j.scitotenv.2015.12.054](https://doi.org/10.1016/j.scitotenv.2015.12.054)

License:

Creative Commons: Attribution-NonCommercial-NoDerivs (CC BY-NC-ND)

*Document Version*

Peer reviewed version

*Citation for published version (Harvard):*

Rauert, C, Kuribara, I, Kataoka, T, Wada, T, Kajiwara, N, Suzuki, G, Takigami, H & Harrad, S 2016, 'Direct contact between dust and HBCD-treated fabrics is an important pathway of source-to-dust transfer', *Science of the Total Environment*, vol. 545-546, pp. 77-83. <https://doi.org/10.1016/j.scitotenv.2015.12.054>

[Link to publication on Research at Birmingham portal](#)

### **Publisher Rights Statement:**

After an embargo period this document is subject to the terms of a Creative Commons Attribution Non-Commercial No Derivatives license

Checked Jan 2016

### **General rights**

Unless a licence is specified above, all rights (including copyright and moral rights) in this document are retained by the authors and/or the copyright holders. The express permission of the copyright holder must be obtained for any use of this material other than for purposes permitted by law.

- Users may freely distribute the URL that is used to identify this publication.
- Users may download and/or print one copy of the publication from the University of Birmingham research portal for the purpose of private study or non-commercial research.
- User may use extracts from the document in line with the concept of 'fair dealing' under the Copyright, Designs and Patents Act 1988 (?)
- Users may not further distribute the material nor use it for the purposes of commercial gain.

Where a licence is displayed above, please note the terms and conditions of the licence govern your use of this document.

When citing, please reference the published version.

### **Take down policy**

While the University of Birmingham exercises care and attention in making items available there are rare occasions when an item has been uploaded in error or has been deemed to be commercially or otherwise sensitive.

If you believe that this is the case for this document, please contact [UBIRA@lists.bham.ac.uk](mailto:UBIRA@lists.bham.ac.uk) providing details and we will remove access to the work immediately and investigate.

**DIRECT CONTACT BETWEEN DUST AND HBCD-TREATED FABRICS IS  
AN IMPORTANT PATHWAY OF SOURCE-TO-DUST TRANSFER**

Cassandra Rauert<sup>a</sup>, Isamu Kuribara<sup>b</sup>, Toshiyuki Kataoka<sup>b</sup>, Takeharu Wada<sup>b</sup>, Natsuko  
Kajiwara<sup>c</sup>, Go Suzuki<sup>c</sup>, Hidetaka Takigami<sup>c</sup>, Stuart Harrad<sup>a</sup>

<sup>a</sup> School of Geography, Earth, and Environmental Sciences, University of  
Birmingham, Birmingham, B15 2TT, UK

<sup>b</sup> Chemicals Evaluation and Research Institute, Japan (CERI), 1600 Shimotakano,  
Sugito-machi, 345-0043, Japan

<sup>c</sup> Center for Material Cycles and Waste Management Research, National Institute for  
Environmental Studies (NIES), 16-2 Onogawa, Tsukuba, 305-8506, Japan

**Corresponding Author**

Stuart Harrad

*Tel +44 (0)121 414 7298*

*S.J.Harrad@bham.ac.uk*

## Abstract

Hexabromocyclododecanes (HBCDs) are a class of brominated flame retardant that have found extensive application in consumer products used widely in indoor environments. Although uncertainty remains about the human health impacts of HBCDs, ingestion of HBCD-contaminated indoor dust has been shown to be a particularly significant exposure pathway for young children. Despite this, understanding of the mechanisms via which HBCDs transfer from products to indoor dust remains incomplete. In this study, an in-house test chamber was used to investigate transfer of HBCDs from a treated textile sample to indoor dust via direct textile:dust contact. Results were compared with previous data using the same test chamber to examine other pathways via which HBCDs transfer from products to dust, and highlighted HBCD transfer *via* direct source:dust contact as being particularly important. This novel finding was corroborated by complementary experiments that examined HBCD transfer via direct contact, from other treated textiles to three major components of indoor dust: artificial indoor dust, soil particles, and cotton linters.

**Keywords**

Brominated flame retardants;

Indoor dust;

Source-to-dust Transfer;

HBCD

**Graphical abstract**

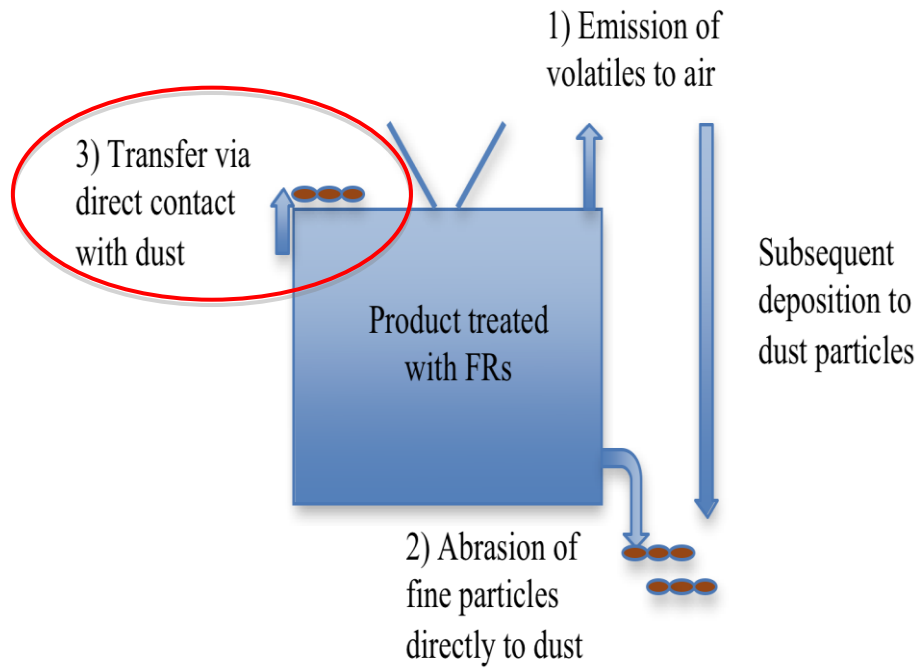

## **Highlights**

Transfer of HBCDs via direct contact between a curtain and dust studied.

Direct curtain:dust contact led to substantial transfer.

Transfer is rapid yet source:dust equilibrium not reached after 1 week of contact.

Results imply regular cleaning of source surfaces may reduce contamination of dust.

## Introduction

Hexabromocyclododecanes (HBCDs) are one of the most widely produced classes of brominated flame retardants (BFRs) used to flame retard polystyrene foams for building insulation, fabrics like furniture covers and curtains, and high impact polystyrene casings for electronic equipment (Harrad et al, 2010; Weil and Levchik, 2007). They are incorporated into products *via* an “additive” process where the HBCD formulation is physically rather than chemically bound to the product/polymer. Consequently, their release into the surrounding environment is relatively facile, leading to their ubiquitous presence in indoor air and dust (Harrad et al, 2010; Covaci et al, 2006). Concentrations in dust can vary by orders of magnitude (Abdallah et al, 2008b) up to 1.1 mg  $\Sigma$ HBCDs g<sup>-1</sup> (Allen et al, 2013). Such elevated concentrations are of concern, given dust ingestion contributes an estimated 63% of the exposure of UK toddlers to  $\Sigma$ HBCDs (Abdallah et al, 2008a).

Currently hypothesized pathways of BFR transfer from products to dust include: (1) volatilization of BFRs from products with subsequent partitioning to dust; (2) abrasion via physical wear and tear of products, resulting in transfer of particles or fibers of the product directly to dust and (3) transfer via direct contact between product and dust (Suzuki et al, 2009; Takigami et al, 2008; Wagner et al, 2013; Webster et al, 2009). Test chambers constitute a potentially important tool for investigating source-to-dust transfer of BFRs. While test chamber studies to date have focused largely on contaminant emissions to air to determine specific emission rates (SERs) (Rauert et al, 2014a), the mass transfer to dust of phthalates from wall paint and vinyl flooring has been investigated in modified test chambers (Clausen et al, 2004; Schripp et al, 2010). These studies demonstrated phthalate transfer from source

1 to dust occurred *via* volatilization with subsequent partitioning to dust, and *via* direct  
2 source:dust contact. More recently, a test chamber study by two of the current authors  
3 demonstrated rapid and substantial transfer of PBDEs from a TV casing sample to  
4 dust (Rauert and Harrad, 2015).  
5  
6  
7  
8  
9

10  
11 We have reported previously test chamber experiments simulating source-to-dust  
12 transfer of HBCD *via* partitioning post volatilization and *via* abrasion (Rauert et al,  
13 2014b, 2015). However, to our knowledge, transfer of HBCD via direct source:dust  
14 contact has hitherto not been investigated.  
15  
16  
17  
18  
19  
20  
21  
22  
23

24 This study is the first experimental investigation of HBCD transfer to dust through  
25 direct source:dust contact, using a test chamber and a HBCD-treated curtain as the  
26 source. Results are compared to previous data reporting HBCD transfer to dust *via*  
27 transfer pathways (1) and (2). Moreover, given the lack of previous data concerning  
28 transfer of HBCDs via direct source:dust contact; we report a series of  
29 complementary, more detailed follow-up experiments that examine HBCD transfer  
30 via direct contact, from four different treated textiles to three major components of  
31 indoor dust: artificial indoor dust, soil particles, and cotton linters.  
32  
33  
34  
35  
36  
37  
38  
39  
40  
41  
42  
43  
44  
45

## 46 **Materials and Methods**

### 47 *Experimental Design*

#### 48 *Initial Test Chamber Experiments*

49  
50  
51 The cylindrical stainless steel test chamber employed to investigate HBCD migration  
52 from the test curtain to dust is illustrated in Figure 1a. With dimensions of 10 cm  
53 diameter and 20 cm height, volume of 1570 cm<sup>3</sup>, and internal surface area of 785 cm<sup>2</sup>,  
54  
55  
56  
57  
58  
59  
60  
61  
62  
63  
64  
65



1 chamber internal temperature was monitored by a LogTag TRIX-8 temperature data  
2 logger. An aluminium mesh shelf was placed half way down the chamber. A HBCD  
3 treated curtain (7 cm x 3 cm rectangle) was placed on a clean glass fiber filter situated  
4 on the shelf, and a thin layer of previously characterised house dust (Rauert et al,  
5 2015) placed evenly on top of the curtain (~500 mg). Concentrations of HBCD  
6 diastereomers in the curtains used in test chamber experiments were 18,000,000 ng g<sup>-1</sup>  
7 for  $\alpha$ -HBCD, 7,500,000 ng g<sup>-1</sup> for  $\beta$ -HBCD, and 17,000,000 ng g<sup>-1</sup> for  $\gamma$ -HBCD  
8 (Kajiwara et al, 2013). Dust utilized in test chamber experiments contained low  
9 concentrations of HBCDs and PBDEs ( $\Sigma$ HBCDs = 110 ng g<sup>-1</sup> and  $\Sigma$ PBDEs = 280 ng  
10 g<sup>-1</sup>). The percentage carbon and nitrogen content of this dust was determined, with  
11 results supplied as supplementary data (Table SD-1).  
12  
13  
14  
15  
16  
17  
18  
19  
20  
21  
22  
23  
24  
25  
26  
27  
28

29 The chamber was sealed and left at room temperature (22 ± 1 °C) for either 24 hours  
30 or 1 week. Post-experiment dust was gently removed from the source by gentle  
31 tapping, and homogenized via vortex mixing, ready for analysis. Each time period  
32 was studied in quadruplicate with duplicate dust subsamples (200 mg) from each  
33 experiment analyzed for HBCDs.  
34  
35  
36  
37  
38  
39  
40  
41  
42  
43

#### 44 *Follow-up experiments*

45 Figure 1b illustrates the experimental configuration employed in follow-up  
46 experiments. Four different kinds of HBCD-treated fabrics including 2 curtains  
47 (Curtain-1 and -2) and 2 vehicle seat fabrics (Seat fabric-1 and -2) were used. These  
48 materials were manufactured in Japan prior to HBCD's listing as a persistent organic  
49 pollutant (POP) under the Stockholm Convention (Annex A). HBCD concentrations  
50 in these fabrics ranged from 8,400,000 ng g<sup>-1</sup> to 21,000,000 ng g<sup>-1</sup> (Table 3). Each  
51  
52  
53  
54  
55  
56  
57  
58  
59  
60  
61  
62  
63  
64  
65

1 fabric material tested was fixed within a rectangular aluminium frame (outer  
2 dimensions 115 mm x 150 mm) with two windows each 53 mm x 83 mm. Prior to  
3  
4 each experiment, the test fabric surface was vacuumed to remove small abraded fibers  
5  
6 to minimize their inadvertent incorporation in the test dust. Three different types of  
7  
8 test particles were used in follow-up experiments. These were: (1) artificial indoor  
9  
10 dust (JIS Z 8901 Class 15, see below); (2) fine soil particle (calcined Kanto loam at  
11  
12 800 °C, JIS Z 8901 Class 8, median diameter 6.6–8.6 µm, density 2.9–3.1 g/cm<sup>3</sup>,  
13  
14 ignition loss 0–4%); and (3) cotton linters (<1.5 µm in diameter, <1 mm in length)  
15  
16 (JIS, 2006). The artificial indoor dust was a mixture of test particles, containing 72%  
17  
18 fine soil particles (JIS Z 8901 Class 8), 23% carbon black (JIS Z 8901 Class 12, 0.03–  
19  
20 0.20 µm, 1.7–1.9 g/cm<sup>3</sup>) and 5% cotton linters. The fine soil particles used are  
21  
22 primarily inorganic, with negligible organic matter since they were prepared by  
23  
24 calcination of loam soil at 800 °C. Initial concentrations of HBCDs in the three test  
25  
26 dust types were all below detection limits.  
27  
28  
29  
30  
31  
32  
33  
34  
35

36 Approximately 20-50 mg of test dust, soil or lint were placed within a 25 mm  
37  
38 diameter circle on the surface of the HBCD-treated fabric material in the upper  
39  
40 window (Figure 1b) using a glass cylinder. Excessive dust was removed by gently  
41  
42 tapping the reverse side of the aluminium frame. The exposed fabric surface in the  
43  
44 lower window (Figure 1b) was used as a control without dust. An additional blank  
45  
46 using dust applied to aluminium foil, instead of a HBCD treated fabric, was also  
47  
48 conducted. Each frame was then shielded from light with aluminium foil and  
49  
50 maintained at 28°C and 50% relative humidity in a thermohygrostat test chamber  
51  
52 (IG400, Yamato Scientific, Tokyo, Japan). Three experimental durations were  
53  
54 examined: 1, 4, and 7 days. Transfer of HBCDs to artificial indoor dust was examined  
55  
56  
57  
58  
59  
60  
61  
62  
63  
64  
65

1 for each of the 4 HBCD-treated fabric materials over three experimental durations. In  
2 contrast, transfer to the fine soil particle and cotton linter samples were examined over  
3  
4 a single 4 day period for curtains only. Duplicate tests were conducted for Curtain-1  
5  
6 (all dust types) and Seat fabric-1 (artificial indoor dust only). Following each  
7  
8 experiment, dust was collected from the surface of each fabric window (with or  
9  
10 without dust) and from the aluminium foil by a low volume vacuum pump equipped  
11  
12 with a stainless steel filter holder (KS-25, ADVANTEC, Tokyo, Japan) containing a  
13  
14 glass fiber filter (GB-100R, 25 cm diameter, 0.6  $\mu\text{m}$  pore size, ADVANTEC, Tokyo,  
15  
16 Japan). Dust collected was weighed and analyzed for HBCDs.  
17  
18  
19  
20  
21  
22  
23

#### 24 *Determination of concentrations of HBCDs*

##### 25 *Test chamber experiment samples*

26  
27 Dust from test chamber experiments was analyzed using modified in-house methods  
28  
29 (Rauert et al, 2015). A detailed description is provided as supplementary data. Method  
30  
31 blanks run with each batch of samples were conducted by extracting a pre-cleaned 66  
32  
33 mL cell filled with hydromatrix. For  $^{13}\text{C}$ - $\alpha$ -,  $\beta$ -, and  $\gamma$ -HBCDs, average recoveries  
34  
35 ranged from 71 to 85%. Accuracy and precision was assessed via replicate analyses  
36  
37 (n=15) of NIST SRM 2585. Results were compared with indicative values  
38  
39 (supplementary information, Table SD-2) (Keller et al, 2007). Statistical analysis was  
40  
41 conducted using SPSS Version 22 with significance levels set at 0.05.  
42  
43  
44  
45  
46  
47  
48  
49  
50

##### 51 *Follow-up experiment samples*

52  
53 A full description of the methods used to determine HBCDs in follow-up experiments  
54  
55 is supplied as supplementary data. Method blanks in follow-up experiments were  
56  
57 conducted in parallel via two types of blank test: (1) a dust blank using aluminium foil  
58  
59  
60  
61  
62  
63  
64  
65

1 instead of HBCD treated fabric to examine cross contamination between test samples;  
2 and (2) a fabric blank test whereby the fabric was vacuumed in the absence of dust to  
3 evaluate possible co-removal onto the glass fiber filter of small fabric fibers during  
4 vacuuming. Concentrations of HBCDs in the dust blank were below detection limits.  
5  
6 In fabric blank samples, concentrations of HBCDs were about 100 times lower than  
7 those obtained in the presence of dust.  
8  
9

## 10 **Results and Discussion**

11  
12  
13  
14  
15  
16  
17  
18  
19 *Test chamber experiments examining HBCD transfer via direct contact between*  
20  
21 *source:dust*

22  
23  
24 Average concentrations of HBCDs in dust ( $\text{ng g}^{-1}$ ) from pre- and post-chamber  
25 experiments are given in Table 1. Regardless of duration, a clear increase in HBCD  
26 dust concentrations was observed post-experiment. However, no statistically  
27 significant difference ( $p > 0.1$ , independent samples t-test) was observed between  
28 concentrations after 24 hours ( $1,500\text{-}14,000 \text{ ng g}^{-1} \Sigma\text{HBCDs}$ ) and 1 week's contact  
29 ( $5,200\text{-}9,300 \text{ ng g}^{-1} \Sigma\text{HBCDs}$ ).  
30  
31  
32  
33  
34  
35  
36  
37  
38  
39  
40

41 However, replicate chamber experiments conducted over the same experimental  
42 duration displayed substantial (up to an order of magnitude) differences in  
43 concentrations of HBCDs in dust post-experiment. Moreover, HBCD concentrations  
44 varied considerably between sub-samples of dust taken at the end of the same  
45 experiment. This sizeable intra-experimental variation in HBCD concentrations in  
46 post-experiment dust made any increase in HBCD transfer between the 24 hour and 1  
47 week experiments difficult to discern. Hence, these experiments could not evaluate  
48 reliably whether source-to-dust transfer occurred rapidly and whether equilibrium was  
49  
50  
51  
52  
53  
54  
55  
56  
57  
58  
59  
60  
61  
62  
63  
64  
65

1 reached within 1 week. We believe the variable HBCD concentrations in these initial  
2 experiments most likely arose from uneven transfer of abraded curtain fibers into dust  
3 when sampled post-experiment. At the end of each experiment, dust was collected by  
4 gently brushing/tapping the fabric. This may have caused transfer of friable curtain  
5 fibers, which if heterogeneously distributed within the dust will cause an  
6 inhomogeneous distribution of HBCD throughout the dust. This hypothesis is  
7 supported by Clausen et al (2004) who investigated direct transfer of di(2-ethylhexyl)  
8 phthalate (DEHP) via contact between treated polyvinylchloride (PVC) pieces and  
9 dust. The authors suggested vacuuming the dust from the source surface affected the  
10 transfer of abraded PVC particles treated with DEHP into the dust.  
11  
12  
13  
14  
15  
16  
17  
18  
19  
20  
21  
22  
23  
24  
25

26 Coupled with this, it is possible dust in contact with the curtain will display a  
27 heterogeneous distribution of organic carbon. HBCDs sorb more strongly to matrices  
28 with higher organic carbon content (Abdallah et al, 2012). In the context of source-to-  
29 dust transfer of organic contaminants, a weak correlation between uptake of di-n-butyl  
30 phthalate and the organic content of the receiving matrix was reported (Schripp et al,  
31 2010). Consequently, variations in organic carbon distribution throughout the  
32 receiving dust could partly account for variable HBCD concentrations in dust post-  
33 experiment. To examine this further, the organic carbon content of test chamber  
34 experiment dust was determined in quadruplicate, revealing an average organic  
35 carbon concentration of 12.7% with a standard deviation of 2.5% (Table SD-1),  
36 consistent with a heterogeneous distribution.  
37  
38  
39  
40  
41  
42  
43  
44  
45  
46  
47  
48  
49  
50  
51  
52  
53

54 Source-to-dust transfer is a function of the fugacity gradient of HBCD in the textile  
55 surface and dust, if the source:air interface boundary layer is partially absent (Clausen  
56  
57  
58  
59  
60  
61  
62  
63  
64  
65

1  
2  
3  
4  
5  
6  
7  
8  
9  
10  
11  
12  
13  
14  
15  
16  
17  
18  
19  
20  
21  
22  
23  
24  
25  
26  
27  
28  
29  
30  
31  
32  
33  
34  
35  
36  
37  
38  
39  
40  
41  
42  
43  
44  
45  
46  
47  
48  
49  
50  
51  
52  
53  
54  
55  
56  
57  
58  
59  
60  
61  
62  
63  
64  
65

et al, 2004). A fugacity gradient will promote HBCD transfer from the material in which HBCD fugacity is high to the material in which its fugacity is lower, and the stronger this fugacity gradient, the more rapid the mass transfer. The fugacity is a product of the fugacity capacity of the material and the HBCD concentration in the material. Hence, the fugacity gradient between the two materials is driven largely by the HBCD concentration gradient. Given HBCD concentrations in the curtain exceed substantially those in pre-experiment dust, transfer should be substantial and rapid, with both observations consistent with those seen here.

While this study is only the second to address source-to-dust transfer of BFRs, others have investigated uptake of phthalates to dust via direct contact, successfully replicating this migration pathway in test cell experiments (Clausen et al, 2004; Schripp et al, 2010). Schripp et al (2010) hypothesized such mass transfer results from contact between the dust mass and the boundary layer of the source:air interface. HBCD concentrations in the boundary layer will exceed substantially those in the well-mixed air above, providing increased contact with and rapid transfer to dust, due to the greater gradient between HBCD concentrations in boundary layer air and the dust. However, Clausen et al (2004) suggested direct contact between dust and source partially eliminates the boundary layer, allowing dust particles to act as a sorbent accumulating the contaminant directly from the source surface. In this scenario, dust uptake will be less dependent on contaminant volatility and more on its availability at the source surface.

*Comparison of direct source:dust contact with other source-to-dust transfer pathways*

1 We have reported previously experiments using different configurations of the test  
2 chamber used here, that demonstrated migration of HBCDs from the same curtain  
3 fabric to dust *via* partitioning post-volatilization and abrasion (Rauert et al, 2014b,  
4 2015). Table 2 compares concentrations of HBCDs in dust following these earlier test  
5 chamber experiments with those arising via direct source:dust contact.  
6  
7  
8  
9  
10

11  
12  
13  
14 Table 2 shows migration *via* direct contact between the HBCD source and dust was  
15 rapid and yielded higher HBCD concentrations in dust (1,500-14,000 ng g<sup>-1</sup> ΣHBCDs)  
16 than the volatilization experiments. Consistent with this, Clausen et al (2004) reported  
17 increased mass (up to four times) of DEHP transferred to dust *via* direct contact than  
18 emitted to air from the source over the same experimental duration. Similarly rapid  
19 transfer via direct source:dust contact was observed for BDE-209 (Rauert and Harrad,  
20 2015). Moreover, while Table 2 shows the longer duration abrasion experiments  
21 afforded higher HBCD concentrations in receiving dust; concentrations in 2 h and 3 h  
22 abrasion experiments were very similar to those from our direct source:dust contact  
23 experiments. This is important, given Rauert et al (2014b) reported the experimental  
24 durations of the abrasion experiments, likely exceed realistic wear and tear of  
25 domestic soft furnishings and curtains. While it is recognised that abrasion of the  
26 source is possible in these direct contact experiments and may contribute some mass  
27 transfer (and explain heterogeneity of HBCDs in the dust); we do not believe it can  
28 entirely account for the large concentration increase observed, due to the gentle  
29 handling of the source material (and the absence of any visible fibres in the sampled  
30 dust). Table 2 highlights the importance of direct source:dust contact as a pathway via  
31 which HBCDs (and by extrapolation, similar contaminants) transfer from source  
32 materials to dust.  
33  
34  
35  
36  
37  
38  
39  
40  
41  
42  
43  
44  
45  
46  
47  
48  
49  
50  
51  
52  
53  
54  
55  
56  
57  
58  
59  
60  
61  
62  
63  
64  
65

1  
2  
3 *Results of Follow-up Experiments*  
4

5 Figure 2 gives concentrations of  $\Sigma$ HBCDs in the artificial indoor dust samples  
6 analysed, with concentrations of individual HBCD diastereomers supplied as Table  
7 4). While initial concentrations in dust (pre-contact with fabrics) were below detection  
8 limits, concentrations after just 1 day's contact exceeded 2,000 ng g<sup>-1</sup> and reached  
9 23,000 ng g<sup>-1</sup> in artificial dust in contact with Seat fabric-2 for 7 days. This  
10 demonstrates substantial HBCD transfer following direct contact between fabrics and  
11 dust, and confirms the findings of the test chamber experiments, that this pathway is a  
12 highly effective vector via which HBCDs transfer from treated fabrics to dust.  
13  
14  
15  
16  
17  
18  
19  
20  
21  
22  
23  
24  
25  
26

27 In test chamber experiments, HBCD concentrations in dust in contact with the curtain  
28 for 1 week were not significantly different to those after 24 hours of contact, likely  
29 due to between-dust sample variations in inadvertent transfer of curtain fibers during  
30 dust sample collection and the organic carbon content of the dust. In follow-up  
31 experiments, inadvertent transfer of fabric fibers to dust was minimized via careful  
32 vacuuming of the test fabric pre-experiment. Moreover, the organic carbon content of  
33 dust was homogeneously distributed (see Table SD-1). Consequently, Figure 2  
34 illustrates the clear increase in concentrations of HBCDs in dust with increasing  
35 contact time. This confirms transfer is rapid but that even after 1 week's contact,  
36 source:dust equilibrium is not reached. This is consistent with our findings in a recent  
37 test chamber study examining the transfer of BDE-209 from plastic TV casing to dust  
38 via direct source-to-dust contact (Rauert and Harrad, 2015).  
39  
40  
41  
42  
43  
44  
45  
46  
47  
48  
49  
50  
51  
52  
53  
54  
55  
56  
57  
58  
59  
60  
61  
62  
63  
64  
65



1  
2  
3  
4  
5  
6  
7  
8  
9  
10  
11  
12  
13  
14  
15  
16  
17  
18  
19  
20  
21  
22  
23  
24  
25  
26  
27  
28  
29  
30  
31  
32  
33  
34  
35  
36  
37  
38  
39  
40  
41  
42  
43  
44  
45  
46  
47  
48  
49  
50  
51  
52  
53  
54  
55  
56  
57  
58  
59  
60  
61  
62  
63  
64  
65

Figure 3 compares HBCD diastereomer profiles in the 4 fabrics studied with those detected in artificial dust samples contacted with the fabrics for 4 days. In each case, there is a demonstrable shift from the pattern in the fabrics, where  $\gamma$ -HBCD predominates, to one where  $\alpha$ -HBCD is far more abundant in the dust. This profile shift provides strong evidence that the elevated concentrations in dust in these experiments have not arisen via transfer to dust of abraded fabric fibers. Instead, this pattern shift is consistent with the scenario outlined elsewhere, whereby HBCD uptake by dust occurs via contact with the boundary layer of the source:air interface (Schripp et al, 2010). The reported higher vapor pressure of  $\alpha$ -HBCD compared to  $\gamma$ -HBCD (Kuramochi et al, 2010), would yield a boundary layer diastereomer pattern enriched in  $\alpha$ -HBCD relative to that in the fabric. In contrast, the similar diastereomer profiles in curtains and post-experiment dust in our test chamber experiments, may be influenced from transferred abraded fabric fibers to the dust. However, our tentative findings of direct HBCD transfer from fabrics to dust, contrast with our earlier findings for PBDE transfer to dust via direct contact with plastic TV casing (Rauert and Harrad, 2015). In this earlier study, we found PBDE congener ratios in dust matched those observed in that of the TV casing, an observation that is more consistent with the hypothesis of Clausen et al (2004), where a dust layer disrupts the boundary layer surrounding the source, allowing direct uptake to dust particles of a chemical from the source surface. Further detailed study of the mechanisms governing BFR transfer from a source to dust therefore appears a research priority to clarify results.

To evaluate the effect of organic carbon content on HBCD transfer from treated fabrics to dust, follow-up experiments were conducted with three different types of

1 JIS test particles: artificial indoor dust, fine soil particles, and cotton linters. Figure 4  
2 shows that HBCDs in the fabrics transfer to all three dust sample types after 4 days  
3 contact time, indicating HBCD transfer is not dominated solely by dust organic  
4 carbon content, since the soil particles used contained negligible organic matter. The  
5 relative abundance of  $\alpha$ -HBCD post-experiment in all the three dust types (Figure 4)  
6 exceeded that in the fabrics (Figure 3). Concentrations of HBCDs in dust post-contact  
7 Curtain-1, were broadly similar regardless of dust type. In contrast, post-contact  
8 Curtain-2, HBCD concentrations in cotton linters were lower than those in other dust  
9 types. We cannot explain the different transfer patterns observed for the two curtain  
10 samples, but it may be attributable to differences in texture and/or manufacturing  
11 process of the two test fabrics.  
12  
13  
14  
15  
16  
17  
18  
19  
20  
21  
22  
23  
24  
25  
26  
27  
28

29 This study presents substantial evidence that direct contact between HBCD-treated  
30 fabrics and dust constitutes an effective transfer mechanism. Comparison with  
31 previous test chamber experiments with the same fabric and dust, suggests under real-  
32 world conditions, direct source:dust contact may represent the most important transfer  
33 pathway for HBCDs. This is consistent with our recent parallel test chamber study in  
34 which substantial transfer of PBDEs from plastic TV casing to dust was demonstrated  
35 (Rauert and Harrad, 2015). To confirm this novel and important finding, further  
36 experiments are recommended to evaluate in more detail the importance of and the  
37 mechanisms governing direct source:dust contact as a pathway via which HBCDs and  
38 other BFRs undergo transfer from source materials to indoor dust. A particular focus  
39 should include studies to elucidate the role of the source:dust boundary layer in  
40 effecting contaminant transfer. Our findings have practical implications for reducing  
41  
42  
43  
44  
45  
46  
47  
48  
49  
50  
51  
52  
53  
54  
55  
56  
57  
58  
59  
60  
61  
62  
63  
64  
65

1  
2  
3  
4  
5  
6  
7  
8  
9  
10  
11  
12  
13  
14  
15  
16  
17  
18  
19  
20  
21  
22  
23  
24  
25  
26  
27  
28  
29  
30  
31  
32  
33  
34  
35  
36  
37  
38  
39  
40  
41  
42  
43  
44  
45  
46  
47  
48  
49  
50  
51  
52  
53  
54  
55  
56  
57  
58  
59  
60  
61  
62  
63  
64  
65

contamination of indoor dust with contaminants like HBCDs, as they imply regular removal of dust from source surfaces will reduce contamination.

### **Acknowledgements**

The research leading to these results received funding from the European Union Seventh Framework Program (*FP7/2007-2013*) under grant agreement No 264600 (INFLAME project), and from the Ministry of Economy, Trade and Industry, Japan.

### **Dedication**

This article is dedicated to the memory of our friend and colleague, Dr. Hidetaka Takigami, who sadly died after completion of this study.

### **Supplementary Data**

Supplementary data to this article consists of descriptions of methods used to determine HBCDs in samples, plus tables reporting QA/QC data and concentrations of HBCDs in follow-up experiment dust samples.

### **References**

Abdallah, M.A.-E., Harrad, S., Covaci, A., 2008a. Hexabromocyclododecanes and Tetrabromobisphenol-A in Indoor Air and Dust in Birmingham, UK: Implications for Human Exposure. *Environ. Sci. Technol.*, 42, 6855-6861.

Abdallah, M.A.-E., Harrad, S., Ibarra, C., Diamond, M.L., Melymuk, L., Robson, M., Covaci, A., 2008b. Hexabromocyclodocanes in indoor dust from Canada, United Kingdom and United States. *Environ. Sci. Technol.*, 42, 459-464.

Commercial Use or Development *J. Fire Sci.* 25, 241-265.

1  
2  
3  
4  
5  
6  
7  
8  
9  
10  
11  
12  
13  
14  
15  
16  
17  
18  
19  
20  
21  
22  
23  
24  
25  
26  
27  
28  
29  
30  
31  
32  
33  
34  
35  
36  
37  
38  
39  
40  
41  
42  
43  
44  
45  
46  
47  
48  
49  
50  
51  
52  
53  
54  
55  
56  
57  
58  
59  
60  
61  
62  
63  
64  
65

Abdallah, M.A.-E., Tilston, E., Harrad, S., Collins, C., 2012. *In vitro* assessment of the bioaccessibility of brominated flame retardants in indoor dust using a colon extended model of the human gastrointestinal tract. *J. Environ. Monit.*, 14, 3276-3283.

Allen, J.G., Stapleton, H.M., Vallarino, J., McNeely, E., McClean, M.D., Harrad, S.J., Rauert, C.B., Spengler, J.D., 2013. Exposure to flame retardant chemicals on commercial airplanes. *Environ. Hlth.*, 12, 17.

Clausen, P.A., Hansen, V., Gunnarsen, L., Afshari, A., Wolkoff, P., 2004. Emission of Di-2-ethylhexyl Phthalate from PVC Flooring into Air and Uptake in Dust: Emission and Sorption Experiments in FLEC and CLIMPAQ. *Environ. Sci. Technol.*, 38, 2531-2537.

Covaci, A., Gerecke, A.C., Law, R.J., Voorspoels, S., Kohler, M., Heeb, N.V., Leslie, H., Allchin, C.R.; de Boer, J., Hexabromocyclododecanes (HBCDs) in the Environment and Humans: A Review. 2006. *Environ. Sci. Technol.*, 40, 3679-3688.

Harrad, S., Abdallah, M.A.-E., Covaci, A., 2009. Causes of variability in concentrations and diastereomer patterns of hexabromocyclododecanes in indoor dust. *Environ. Int.*, 35, 573-579.

Harrad, S., de Wit, C.A., Abdallah, M.A.-E., Bergh, C., Björklund, J.A., Covaci, A., Darnerud, P.O., de Boer, J., Diamond, M., Huber, S., Leonards, P., Mandalakis, M., Östman, C., Småstuen Haug, L., Thomsen, C., Webster, T.F., 2010. Indoor Contamination with Hexabromocyclododecanes, Polybrominated Diphenyl Ethers and Perfluoroalkyl Compounds: An Important Exposure Pathway for People? *Environ. Sci. Technol.* 44, 3221–3231.

JIS, 2006. Test powders and test particles, Z 8901 (in Japanese)

1 Kajiwara, N., Desborough, J., Harrad, S., Takigami, H., 2013. Photolysis of  
2 brominated flame retardants in textiles exposed to natural sunlight. *Environ. Sci.*  
3  
4 *Proc. Imp.*, 15, 653-660.  
5  
6

7 Keller, J.M., Stapleton, H.M., Heltsley, R., Peck, A., Kucklick, J.R., Schantz,  
8  
9 M.M., Wise, S.A., 2007. Standard reference materials available from the National  
10  
11 Institute of Standards and Technology for the analysis of brominated flame  
12  
13 retardants. Poster presented at BFR 2007; The Netherlands: Amsterdam.  
14  
15  
16

17 Kuramochi H., Sakai S., 2010. Measurement of vapor pressures of some  
18  
19 PBDEs and HBCD diastereoisomers. Presented at BFR2010, Kyoto, Japan,  
20  
21 Abstracts, 90071.pdf  
22  
23

24 Rauert, C., Lazarov, B., Harrad, S., Covaci, A., Stranger, M., 2014a. A review  
25  
26 of chamber experiments for determining specific emission rates and investigating  
27  
28 migration pathways of flame retardants. *Atmos. Environ.*, 82, 44-55.  
29  
30

31 Rauert, C., Harrad, S., Suzuki, G., Takigami, H., Uchida, N., Takata, K.,  
32  
33 2014b. Test chamber and forensic microscopy investigation of the transfer of  
34  
35 brominated flame retardants into indoor dust via abrasion of source materials. *Sci.*  
36  
37 *Tot. Environ.*, 493, 639-648.  
38  
39  
40

41 Rauert, C., Harrad, S., 2015. Mass transfer of PBDEs from plastic TV casing  
42  
43 to indoor dust via three migration pathways — A test chamber investigation. *Sci.*  
44  
45 *Tot. Environ.*, 536, 568-574.  
46  
47

48 Rauert, C., Harrad, S., Stranger, M., Lazarov, B., 2015. Test chamber  
49  
50 investigation of the volatilization from source materials of brominated flame  
51  
52 retardants and their subsequent deposition to indoor dust. *Indoor Air*, 25, 393-404.  
53  
54  
55  
56  
57  
58  
59  
60  
61  
62  
63  
64  
65

1 Schripp, T., Fauck, C., Salthammer, T., 2010. Chamber studies on mass-  
2 transfer of di(2-ethylhexyl)phthalate (DEHP) and di-n-butylphthalate (DnBP) from  
3 emission sources into house dust. *Atmos. Environ.*, 44, 2840-2845.  
4  
5

6  
7 Takigami, H., Suzuki, G., Hirai, Y., Sakai, S.-I., 2008. Transfer of brominated  
8 flame retardants from components into dust inside television cabinets.  
9  
10  
11  
12 *Chemosphere*, 73, 161-169.  
13

14  
15 Wagner, J., Ghosal, S., Whitehead, T., Metayer, C., 2013. Morphology, spatial  
16 distribution, and concentration of flame retardants in consumer products and  
17 environmental dusts using scanning electron microscopy and Raman micro-  
18 spectroscopy. *Environ. Int.*, 59, 16-26.  
19  
20  
21  
22

23  
24 Webster, T.F., Harrad, S., Millette, J.R., Holbrook, R.D., Davis, J.M.,  
25 Stapleton, H.M., Allen, J.G., McClean, M.D., Ibarra, C., Abdallah, M.A.-E., Covaci,  
26 A., 2009. Identifying Transfer Mechanisms and Sources of Decabromodiphenyl  
27 Ether (BDE 209) in Indoor Environments Using Environmental Forensic  
28 Microscopy, *Environ. Sci. Technol.*, 43, 3067-3072.  
29  
30  
31  
32  
33

34  
35  
36 Weil, E.D., Levchik, S.V., 2007. Flame Retardants for Polystyrenes in Suzuki,  
37 G., Kida, A., Sakai, S., Takigami, H., 2009. Existence state of bromine as an  
38 indicator of the source of brominated flame retardants in indoor dust. *Environ. Sci.*  
39  
40  
41  
42  
43  
44  
45  
46  
47  
48  
49  
50  
51  
52  
53  
54  
55  
56  
57  
58  
59  
60  
61  
62  
63  
64  
65

## Figures and Tables

1  
2  
3  
4  
5  
6  
7  
8  
9  
10  
11  
12  
13  
14  
15  
16  
17  
18  
19  
20  
21  
22  
23  
24  
25  
26  
27  
28  
29  
30  
31  
32  
33  
34  
35  
36  
37  
38  
39  
40  
41  
42  
43  
44  
45  
46  
47  
48  
49  
50  
51  
52  
53  
54  
55  
56  
57  
58  
59  
60  
61  
62  
63  
64  
65

1  
2  
3  
4  
5  
6  
7  
8  
9  
10  
11  
12  
13  
14  
15  
16  
17  
18  
19  
20  
21  
22  
23  
24  
25  
26  
27  
28  
29  
30  
31  
32  
33  
34  
35  
36  
37  
38  
39  
40  
41  
42  
43  
44  
45  
46  
47  
48  
49  
50  
51  
52  
53  
54  
55  
56  
57  
58  
59  
60  
61  
62  
63  
64  
65

**Figure 1: Schematic of experimental configurations used in: (a) test chamber (top) and (b) follow-up experiments (bottom) investigating uptake via direct contact between source and dust**

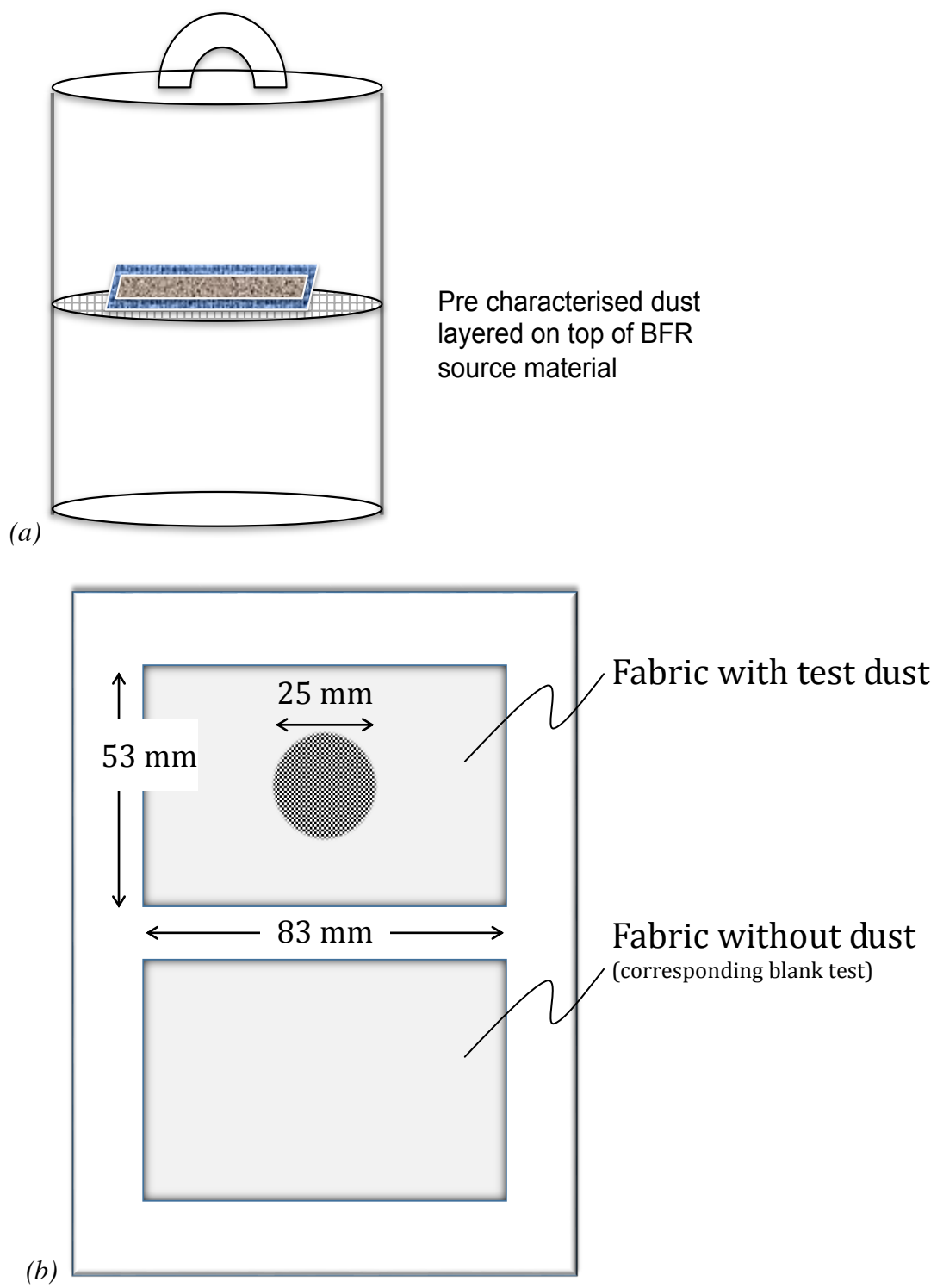



1  
2  
3  
4  
5  
6  
7  
8  
9  
10  
11  
12  
13  
14  
15  
16  
17  
18  
19  
20  
21  
22  
23  
24  
25  
26  
27  
28  
29  
30  
31  
32  
33  
34  
35  
36  
37  
38  
39  
40  
41  
42  
43  
44  
45  
46  
47  
48  
49  
50  
51  
52  
53  
54  
55  
56  
57  
58  
59  
60  
61  
62  
63  
64  
65

**Figure 2. Temporal changes in  $\Sigma$ HBCD concentrations ( $\mu\text{g/g}$ )\* in JIS artificial dust after the follow-up experiments.**

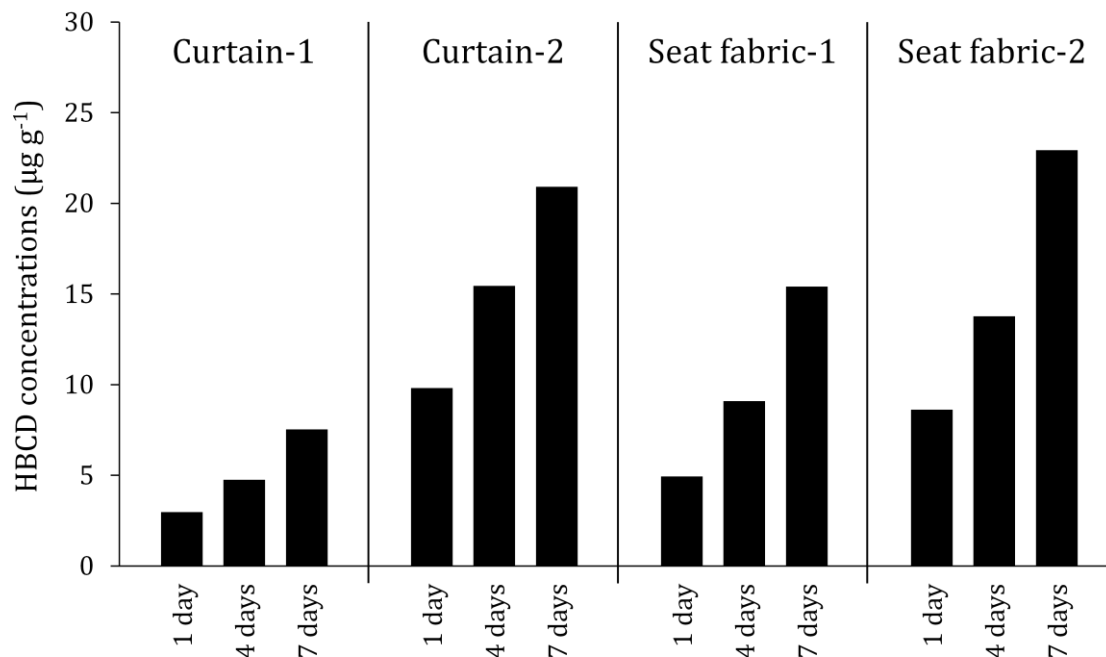

\*After subtracting HBCD concentrations detected in the corresponding blank test.  
Values for Curtain-1 and Seat fabric-1 are the average of duplicate analyses.

1  
2  
3  
4  
5  
6  
7  
8  
9  
10  
11  
12  
13  
14  
15  
16  
17  
18  
19  
20  
21  
22  
23  
24  
25  
26  
27  
28  
29  
30  
31  
32  
33  
34  
35  
36  
37  
38  
39  
40  
41  
42  
43  
44  
45  
46  
47  
48  
49  
50  
51  
52  
53  
54  
55  
56  
57  
58  
59  
60  
61  
62  
63  
64  
65

**Figure 3. HBCD diastereomer profiles in the original fabrics and the artificial dust samples placed in direct contact with the fabrics in the follow-up experiments.**

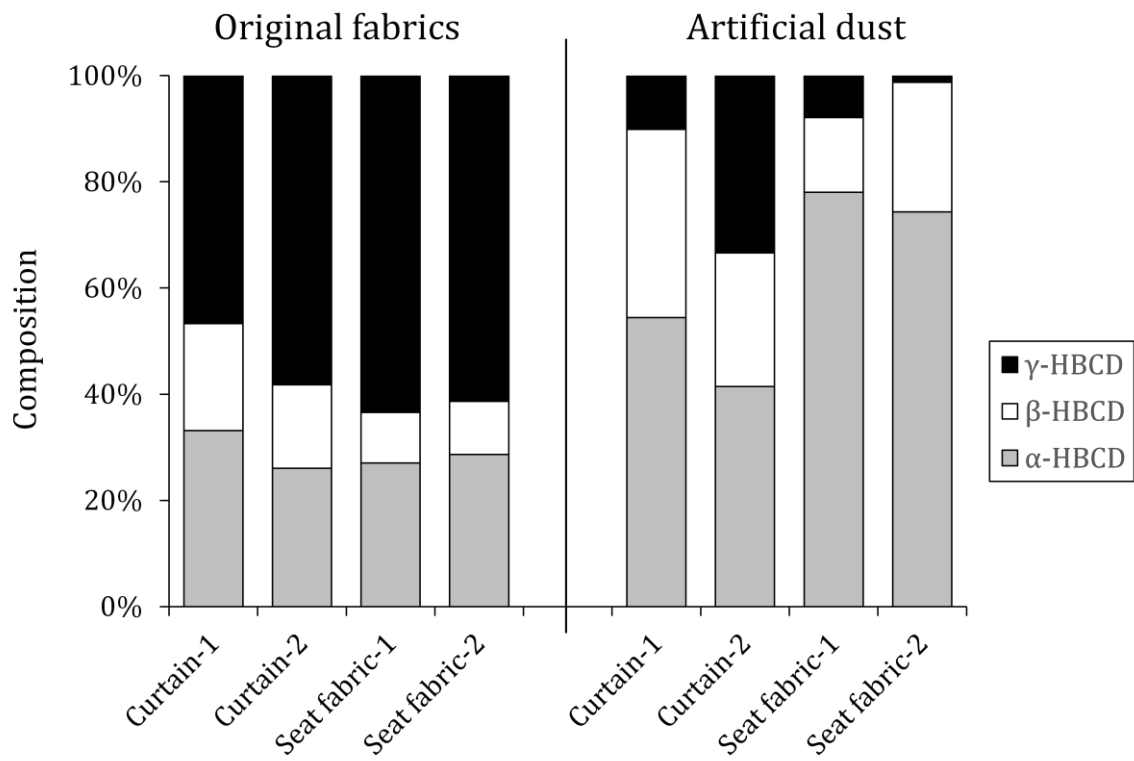

1  
2  
3  
4  
5  
6  
7  
8  
9  
10  
11  
12  
13  
14  
15  
16  
17  
18  
19  
20  
21  
22  
23  
24  
25  
26  
27  
28  
29  
30  
31  
32  
33  
34  
35  
36  
37  
38  
39  
40  
41  
42  
43  
44  
45  
46  
47  
48  
49  
50  
51  
52  
53  
54  
55  
56  
57  
58  
59  
60  
61  
62  
63  
64  
65

**Figure 4. Differences in HBCD diastereomer concentrations transferred to the three different types of JIS test particles during 4 days of contact with treated curtains.**

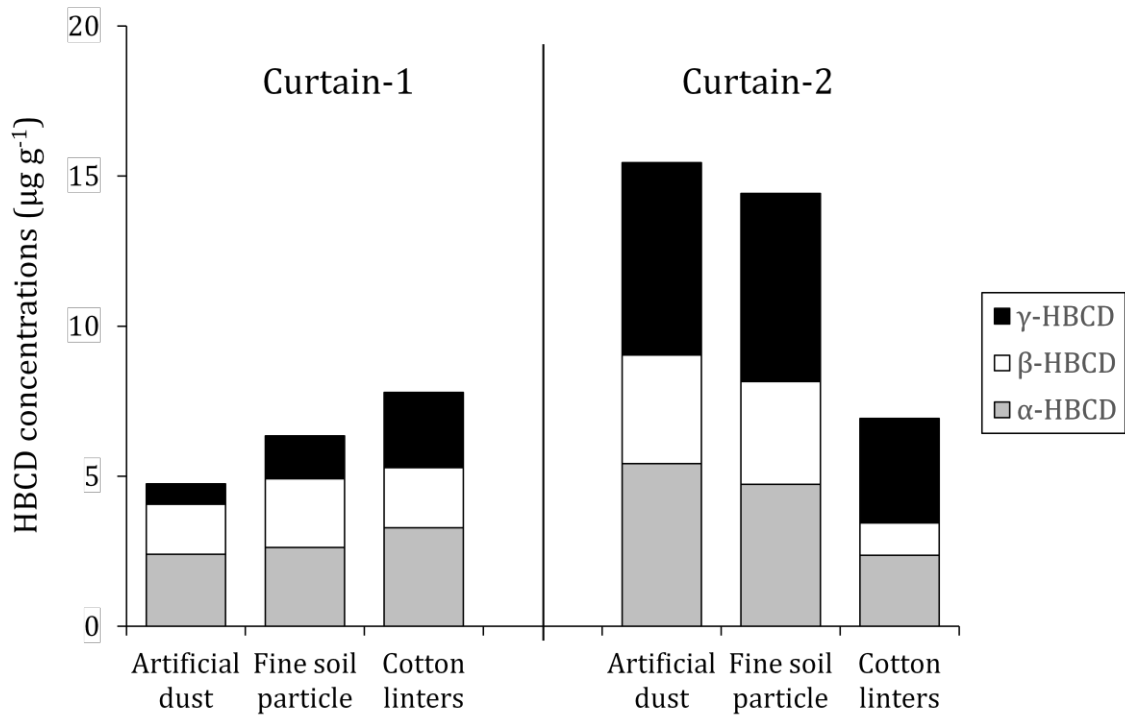

1  
2  
3  
4  
5  
6  
7  
8  
9  
10  
11  
12  
13  
14  
15  
16  
17  
18  
19  
20  
21  
22  
23  
24  
25  
26  
27  
28  
29  
30  
31  
32  
33  
34  
35  
36  
37  
38  
39  
40  
41  
42  
43  
44  
45  
46  
47  
48  
49

**Table 1: Mean and (min, max) concentrations (ng g<sup>-1</sup>) of HBCDs in dust from direct contact test chamber experiments conducted for 24 hours and 1 week**

		<b><math>\alpha</math>-HBCD</b>	<b><math>\beta</math>-HBCD</b>	<b><math>\gamma</math>-HBCD</b>	<b><math>\Sigma</math>HBCDs</b>
<i>Pre experiment dust (ng g<sup>-1</sup>)</i>		<i>46 ± 18</i>	<i>13 ± 10</i>	<i>50 ± 39</i>	<i>110</i>
<b>24 hours</b>	Experiment 1 (n=2)	600 (580, 630)	200 (190, 210)	730 (730, 740)	1500 (1500, 1600)
	Experiment 2 (n=2)	1800 (1500, 2000)	530 (430, 630)	2000 (1700, 2400)	4300 (3600, 5000)
	Experiment 3 (n=2)	5400 (2600, 8200)	1700 (860, 2500)	6400 (3500, 9400)	14 000 (6900, 20 000)
	Experiment 4 (n=2)	2500 (2200, 2700)	800 (750, 860)	3200 (2900, 3500)	6500 (5900, 7000)
<b>1 week</b>	Experiment 1 (n=2)	3700 (3600, 3800)	1300 (1200, 1400)	4300 (4000, 4600)	9300 (8800, 9800)
	Experiment 2 (n=1)	3000	910	3400	7300
	Experiment 3 (n=2)	3000 (1900, 4100)	920 (500, 1400)	3500 (2000, 4900)	7400 (4400, 10 000)
	Experiment 4 (n=2)	2300 (2100, 2400)	590 (560, 620)	2300 (2100, 2600)	5200 (4700, 5600)

**Table 2: Mean ± standard deviation concentrations (ng g<sup>-1</sup>) of HBCDs in dust post-test chamber experiments simulating three different migration pathways of HBCDs to dust from HBCD treated curtains**

	<b>α-HBCD</b>	<b>β-HBCD</b>	<b>γ-HBCD</b>
<b>Volatilization with subsequent partitioning to dust<sup>a</sup></b>			
24 hours @ 60 °C (n=4)	180 ± 52	63 ± 3.8	370 ± 85
1 week @ 22 ± 1 °C (n=3)	160 ± 100	72 ± 60	270 ± 180
<b>Abrasion of fibers directly to dust<sup>a</sup></b>			
2 hours (n=1)	2500	720	3300
3 hours (n=1)	1400	700	2000
21 hours (n=1)	3200	1700	13 000
48 hours (n=1)	23 000	4900	26 000
<b>Direct transfer from source to dust (this study)</b>			
24 hours (n=4)	2600 ± 2000	800 ± 620	2900 ± 2400
1 week (n=4)	3000 ± 600	930 ± 280	3400 ± 790

<sup>a</sup>Data reported in Rauert et al (2014b)

1 **Table 3: Initial concentrations (mg/kg) of HBCD diastereomers in the fabric**  
2 **used in the follow-up experiments**

3

4 ID	Material	$\alpha$ -HBCD	$\beta$ -HBCD	$\gamma$ -HBCD	$\Sigma$ HBCDs
5 Curtain-1	polyester	7,100	4,300	10,000	21,000
6 Curtain-2	polyester	3,800	2,300	8,500	15,000
7 Seat fabric-1	polyester	2,300	810	5,400	8,400
8 Seat fabric-2	polyester	4,300	1,500	9,200	15,000

9  
10  
11  
12  
13  
14  
15  
16  
17  
18  
19  
20  
21  
22  
23  
24  
25  
26  
27  
28  
29  
30  
31  
32  
33  
34  
35  
36  
37  
38  
39  
40  
41  
42  
43  
44  
45  
46  
47  
48  
49  
50  
51  
52  
53  
54  
55  
56  
57  
58  
59  
60  
61  
62  
63  
64  
65

1  
2  
3  
4  
5  
6  
7  
8  
9  
10  
11  
12  
13  
14  
15  
16  
17  
18  
19  
20  
21  
22  
23  
24  
25  
26  
27  
28  
29  
30  
31  
32  
33  
34  
35  
36  
37  
38  
39  
40  
41  
42  
43  
44  
45  
46  
47  
48  
49

**Table 4: HBCD concentrations ( $\mu\text{g/g}$ )\* in JIS test dust after the follow-up experiments**

JIS test dust	Test fabric	Experimental duration (days)	$\alpha$ -HBCD	$\beta$ -HBCD	$\gamma$ -HBCD	$\Sigma$ HBCDs
Artificial dust	Curtain-1**	1	1.4	1.1	0.53	3.0
		4	2.4	1.7	0.68	4.7
		7	4.1	2.7	0.76	7.5
	Curtain-2	1	3.4	2.1	4.3	9.8
		4	5.4	3.6	6.4	15
		7	8.7	5.3	7.0	21
	Seat fabric-1**	1	3.7	0.70	0.50	4.9
		4	7.1	1.3	0.69	9.1
		7	12	2.2	1.2	15
Seat fabric-2	1	6.3	2.2	0.18	8.6	
	4	10	3.4	0.13	14	
	7	17	5.6	0.29	23	
Cotton linter	Curtain-1**	4	3.3	2.0	2.5	7.8
	Curtain-2	4	2.4	1.1	3.5	6.9
Fine soil particle	Curtain-1**	4	2.6	2.3	1.4	6.3
	Curtain-2	4	4.7	3.4	6.3	14

\* After subtracting HBCD concentrations in the corresponding blank test.

\*\* Values are averaged from duplicate analyses.

**Supplementary material for on-line publication only**

[Click here to download Supplementary material for on-line publication only: Rauert et al 2015 SD R2.docx](#)