

# Automated composition of sequence diagrams via alloy

Alwanain, Mohammed; Bordbar, Behzad; Bowles, Juliana K F

*License:*

None: All rights reserved

*Document Version*

Peer reviewed version

*Citation for published version (Harvard):*

Alwanain, M, Bordbar, B & Bowles, JKF 2014, Automated composition of sequence diagrams via alloy. in *MODELSWARD 2014 - Proceedings of the 2nd International Conference on Model-Driven Engineering and Software Development*. Institute of Electrical and Electronics Engineers (IEEE), pp. 384-391, 2nd International Conference on Model-Driven Engineering and Software Development, MODELSWARD 2014, Lisbon, Portugal, 7/01/14. <[http://ieeexplore.ieee.org/xpls/abs\\_all.jsp?arnumber=7018487&tag=1](http://ieeexplore.ieee.org/xpls/abs_all.jsp?arnumber=7018487&tag=1)>

[Link to publication on Research at Birmingham portal](#)

**Publisher Rights Statement:**

(c) 2014 IEEE. Personal use of this material is permitted. Permission from IEEE must be obtained for all other users, including reprinting/republishing this material for advertising or promotional purposes, creating new collective works for resale or redistribution to servers or lists, or reuse of any copyrighted components of this work in other works.

Checked Jan 2016

**General rights**

Unless a licence is specified above, all rights (including copyright and moral rights) in this document are retained by the authors and/or the copyright holders. The express permission of the copyright holder must be obtained for any use of this material other than for purposes permitted by law.

- Users may freely distribute the URL that is used to identify this publication.
- Users may download and/or print one copy of the publication from the University of Birmingham research portal for the purpose of private study or non-commercial research.
- User may use extracts from the document in line with the concept of 'fair dealing' under the Copyright, Designs and Patents Act 1988 (?)
- Users may not further distribute the material nor use it for the purposes of commercial gain.

Where a licence is displayed above, please note the terms and conditions of the licence govern your use of this document.

When citing, please reference the published version.

**Take down policy**

While the University of Birmingham exercises care and attention in making items available there are rare occasions when an item has been uploaded in error or has been deemed to be commercially or otherwise sensitive.

If you believe that this is the case for this document, please contact [UBIRA@lists.bham.ac.uk](mailto:UBIRA@lists.bham.ac.uk) providing details and we will remove access to the work immediately and investigate.

# Automated Composition of Sequence Diagrams via Alloy

Mohammed Alwanain<sup>1</sup>, Behzad Bordbar<sup>1</sup> and Juliana K. F. Bowles<sup>2</sup>

<sup>1</sup>*School of Computer Science, University of Birmingham, England*

<sup>2</sup>*School of Computer Science, University of St Andrews, Scotland*  
{m.l.alwanain, b.bordbar}@cs.bham.ac.uk, jkfb@st-andrews.ac.uk

Keywords: UML Sequence Diagrams, Model Transformation, Composition, Alloy.

Abstract: Design of large systems often involves the creation of models that describe partial specifications. Model composition is the process of combining partial models to create a single coherent model. This paper presents an automatic composition technique for creating a sequence diagram from partial specifications captured in multiple sequence diagrams with the help of Alloy. Our contribution is twofold: a novel true-concurrent semantics for sequence diagram composition, and a model-driven transformation of sequence diagrams onto Alloy that preserves the semantics of composition defined. We have created a tool called *SD2Alloy* that implements the automated technique and works as follows: two given sequence diagrams are transformed in two Alloy models, and then combined according to a set of logical constraints, determined by our compositional semantics, into a final composed Alloy model. The technique can also be used to detect problems and inconsistencies in the composition of diagrams.

## 1 INTRODUCTION

The process of developing modern systems is gradually becoming more and more complex. Due to the increase in the complexity of software development processes, we often make use of multiple models for expressing various scenarios and viewpoints. To reduce the complexity of the design, models of the system are usually broken into partial specifications. For example, behaviour related to the interaction between parts can be captured by different sequence diagrams. However, integrating these diagrams into one to describe the whole behaviour requires *model composition* techniques. Manual model composition is error-prone, time-consuming and tedious (Rosa et al., 2010). In recent years, automated model composition has received considerable attention (Rubin et al., 2008; Widl et al., 2013). For example Rubin et al. (2008) make use of Alloy for automated composition. Nonetheless, most automated merging methods only focus on static representation.

In this paper we deal with automated integration of sequence diagrams, one of UML's behavioural models. In particular, we focus on the composition of sequence diagrams with the help of Alloy. Our contribution is twofold: a novel true-concurrent semantics for sequence diagram composition, and a model-driven transformation of sequence diagrams onto Al-

loy that preserves the semantics of composition.

Our automated technique follows three main steps. In the first step, multiple sequence diagrams are automatically transformed into Alloy models. For each sequence diagram a unique Alloy model is produced which if solved has as many solutions as possible execution traces in the original sequence diagram. The execution traces are the ones obtained in the underlying semantics of sequence diagrams used (Küster-Filipe, 2006). The semantics is defined over the true-concurrent model of labelled event structures (LES) (Winskel and Nielsen, 1995).

In the second step, the Alloy models are merged to produce a single Alloy model, which contains elements from the Alloy model of the sequence diagrams in addition to logical constraints specifying how the sequence diagrams should be composed. Here the logical constraints are derived in accordance to our defined true-concurrent semantics of composition. In the third step, we use the single model to formally check if sequence diagrams can be composed and to work out the composition of the sequence diagrams automatically. These steps are fully automated with our tool *SD2Alloy* which was implemented using Model Driven Architecture (MDA) techniques (Kleppe et al., 2003). Later in the paper, we justify further our choice of Alloy is a target language.

The remainder of the paper is structured as fol-

lows: Section 2 gives a general background of sequence diagrams, their formalisation with event structures and Alloy. Section 3 addresses model composition syntactically (at the UML level) and semantically (over labelled event structures) which guides the model transformation from sequence diagrams onto Alloy as discussed in Section 4. Section 5 describes model composition via Alloy, whereas Section 6 outlines our tool. Finally, Section 7 describes related work and Section 8 concludes the paper.

## 2 BACKGROUND

### 2.1 Sequence Diagrams

UML sequence diagrams capture scenarios of execution as object (or in some cases component) interactions. Each object has a vertical dashed line called *lifeline* showing the existence of the object at a particular time. Points along the lifeline are called *locations* (a terminology borrowed from LSCs (Harel and Marelly, 2003)) and denote the occurrence of events. The order of locations along a lifeline is significant denoting, in general, the order in which the corresponding events occur.

A *message* is a synchronous or asynchronous communication between two objects shown as an arrow connecting the respective lifelines, that is, the underlying send and receive events of the message. We only cover synchronous communication in this paper. An *interaction* between several objects consists of one or more messages, but may be given further structure through so-called *interaction fragments*. There are several kinds of interaction fragments including **seq** (sequential behaviour), **alt** (alternative behaviour), **par** (parallel behaviour), **neg** (forbidden behaviour), **assert** (mandatory behaviour), **loop** (iterative behaviour), and so on (OMG, 2011). Depending on the operator used, an interaction fragment consists of one or more *operands*. In the case of the **alt** fragment, each operand describes a choice of behaviour. Only one of the alternative operands is executed if the guard expression (if present) evaluates to true. If more than one operand has a guard that evaluates to true, one of the operands is selected nondeterministically for execution. In the case of the **par** fragment, there is a parallel merge between the behaviours of the operands. The event occurrences of the different operands can be interleaved in any way as long as the ordering imposed by each operand as such is preserved.

Finally, interaction fragments can be nested producing expressive and complex scenarios of execution. One simple example illustrating the concepts above and with a parallel nested within an alternative fragment is given in Figure 1. In this case, all

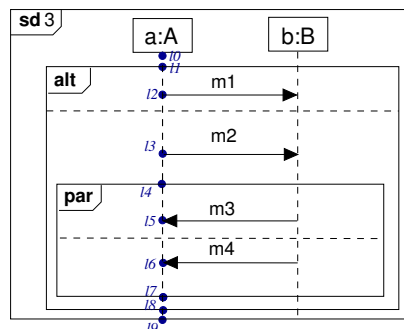

Figure 1: A sequence diagram with nested fragments.

messages (from  $m_1$  to  $m_4$ ) are sent synchronously between objects  $a$  and  $b$ . The locations along the lifeline of object  $a$  are shown explicitly. The importance of locations as well as the effect produced through the nesting of fragments (i.e., the possible traces of execution) are described in the next subsection. In particular, the distinction between the syntactic notion of a location on a sequence diagram from its semantic counterpart of an event will be clarified.

### 2.2 Formal Model

Several possible semantics for sequence diagrams have been defined (see (Micskei and Waeselynck, 2011) for an overview). In this paper we use the semantics defined in (Küster-Filipe, 2006) which introduces a very simple and intuitive behavioural model to capture interactions, and is the only true-concurrent semantics available for sequence diagrams.

Prime event structures (Winskel and Nielsen, 1995), or event structures for short, describe distributed computations as event occurrences together with binary relations for expressing causal dependency (called *causality*) and nondeterminism (called *conflict*). The causality relation implies a (partial) order among event occurrences, while the conflict relation expresses how the occurrence of certain events excludes the occurrence of others. From the two relations defined on the set of events, a further relation is derived, namely the *concurrency* relation  $co$ . Two events are concurrent if and only if they are completely unrelated, i.e., neither related by causality nor by conflict.

Formally, an *event structure* is a triple  $E = (Ev, \rightarrow^*, \#)$  where  $Ev$  is a set of events and  $\rightarrow^*, \# \subseteq$

$Ev \times Ev$  are binary relations called *causality* and *conflict*, respectively. Causality  $\rightarrow^*$  is a partial order. Conflict  $\#$  is symmetric and irreflexive, and propagates over causality, i.e.,  $e\#e' \rightarrow^* e'' \Rightarrow e\#e''$  for all  $e, e', e'' \in Ev$ . Two events  $e, e' \in Ev$  are *concurrent*,  $e \text{ co } e'$  iff  $\neg(e \rightarrow^* e' \vee e' \rightarrow^* e \vee e\#e')$ .

We omit further technical details on the model, but note that for the application of event structures as a semantic model for sequence diagrams we use *discrete* event structures. Discreteness imposes a finiteness constraint on the model, i.e., there are always only a finite number of causally related predecessors to an event, known as the *local configuration* of the event. A further motivation for this constraint is given by the fact that every execution has a starting point or configuration.

Event structures are enriched with a labelling function (usually a total function  $\mu: Ev \rightarrow L$  that maps each event onto an element of the set  $L$ ). This labelling function is necessary to establish a connection between the semantic model (event structure) and the syntactic model (here a sequence diagram).

Intuitively, each location marked along a lifeline of an object in a sequence diagram corresponds to one (possibly more) event(s) in the labelled event structure. The set of labels used could be the set of locations in a sequence diagram but is usually more concrete information on what the location represents: the initialisation of an object, sending/receiving a message, beginning/ending an interaction fragment, etc.

Consider the locations marked on Figure 1 for object  $a$ . The events in the model shown in Figure 2 have a direct correspondence to the locations of object  $a$ .

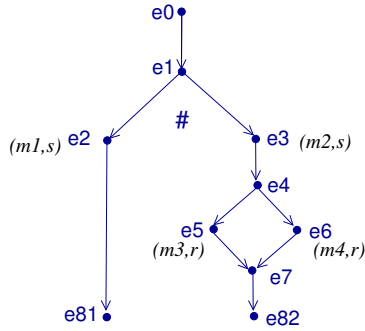

Figure 2: Event structure for object  $a$  of Figure 1.

The graphical representation of the event structure  $E_a$  shows immediate causality between events (e.g.,  $e_0 \rightarrow e_1$ ) and direct conflict (e.g.,  $e_2\#e_3$ ). By conflict propagation we also have  $e_2\#e_4$ , etc. Unrelated events are concurrent (e.g.,  $e_5 \text{ co } e_6$ ). Intuitively, events  $e_1$  and  $e_4$  denote the beginning of the alternative and parallel fragments respectively. Consequently events  $e_5$  (denoting the receipt of message  $m_3$ ) and  $e_6$  (denoting

the receipt of message  $m_4$ ) are concurrent. Events  $e_{81}$  and  $e_{82}$  both correspond to location  $l_8$  denoting the end of the alternative fragment. These events must be in conflict because they represent different ways to reach the location. Note that there cannot be one end event in this case, because conflict propagates over causality and it would lead to an event in conflict with itself and hence an invalid event structure (conflict is irreflexive). Some event labels are given where  $(m_1, s)$  denotes sending message  $m_1$ , and  $(m_3, r)$  denotes receiving message  $m_3$ .

Let  $I$  denote the set of objects involved in the interaction described by sequence diagram  $SD$ . A model  $M_{SD} = (E, \mu)$  for a sequence diagram  $SD$  is obtained by composition of the models  $M_i = (E_i, \mu_i)$  of each object instance  $i \in I$ . In the composed model, the set of events  $Ev$  is such that  $e \in Ev$  iff there is an object  $i \in I$  such that  $e \in E_{v_i}$ , or  $(e_1, e_2) \in Ev$  iff there are two objects  $i \neq j \in I$  with  $e_1 \in E_{v_i}$ ,  $e_2 \in E_{v_j}$ ,  $\mu_i(e_1) = (m, s)$  and  $\mu_j(e_2) = (m, r)$ . In other words, shared events  $(e_1, e_2)$  correspond to message synchronisation. To keep it simple, we assume that  $\mu: Ev \rightarrow Mes$  is a partial function defined over shared events only and indicating the message exchanged. I.e.,  $\mu(e_1, e_2) = m$  iff  $\mu_i(e_1) = (m, s)$  and  $\mu_j(e_2) = (m, r)$  for some  $i, j \in I$ . More details on the semantics of sequence diagrams using event structures can be found in (Küster-Filipe, 2006).

## 2.3 Alloy

Alloy (Jackson, 2006) is a declarative textual modeling language based on first-order relational logic. An Alloy model consists of a number of signature declarations, fields, facts and predicates. Furthermore, each signature denotes a set of atoms, which are the basic entities of Alloy. Alloy is supported by a fully automated constraint solver called *Alloy Analyzer*, which permits the analysis of system properties by searching for instances of the model. It is possible to check whether certain properties of the system are present. This is achieved via an automated translation of the model into a Boolean expression, which is then analysed by SAT solvers such as SAT4 (Berre and Parrain, 2010) embedded within the Alloy Analyzer. The Alloy Analyzer has been used in various applications including the composition of static models (Rubin et al., 2008).

In this paper, Alloy is used as part of an automated tool to compose sequence diagrams. The composition is based on a set of logical constraints which we designate *merging glue*. Alloy is a language for describing the *structural* information underlying a design model whereas labelled event structures are needed to make

sure the semantics of the *behavioural* model and the composition are as expected.

The choice of Alloy as a target framework is a natural one. Alloy makes it straightforward to find a model (if available) for the composition of sequence diagrams. The approach converts each sequence diagram into a set of logical constraints to which it is simple to add additional constraints capturing the *merging glue*. Alloy solves these constraints to *find* a model that complies to both sequence diagrams and the glue.

### 3 MODEL COMPOSITION

For the integration of two or more scenarios we define syntactic composition of sequence diagrams and its underlying semantics.

Our mechanism for composition of sequence diagrams considers interleaving of diagrams and shared behaviour. In the first case, diagrams evolve completely autonomously whereas in the latter case diagrams have shared behaviour (shared objects and messages). We treat the cases separately and consider only the composition of two diagrams. The case for an arbitrary number of diagrams is easily generalised from here. In the sequel, let  $SD_1$  and  $SD_2$  be two sequence diagrams, with sets of instances and messages given by  $I_1, I_2, Mes_1$  and  $Mes_2$  respectively.

The *interleaving* of diagrams  $SD_1$  and  $SD_2$  with  $Mes_1 \cap Mes_2 = \emptyset$  is written  $SD_1 \parallel SD_2$  and is defined syntactically as  $par(SD_1, SD_2)$ . In other words, it consists of a diagram with a *par* fragment and two operands where each operand contains the behaviour described in  $SD_1$  and  $SD_2$  respectively.

Semantically, the model for  $SD_1 \parallel SD_2$  is an event structure  $M_{SD_1 \parallel SD_2} = (E, \mu)$  where  $E_V = E_{V_1} \cup E_{V_2}$ , all relations are preserved, and  $\mu(e)$  is defined for all  $e$  iff  $\mu_i(e)$  is defined for some  $i \in \{1, 2\}$  in which case  $\mu(e) = \mu_i(e)$ . For shared instances  $o \in I_1 \cap I_2$  we further match the initial and maximal events in  $E_{V_1}$  and  $E_{V_2}$ . We illustrate this with an example (see Figure 3) showing shared objects but different messages.

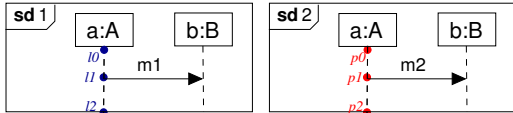

Figure 3: Two simple sequence diagrams

The models associated to  $SD_1$  and  $SD_2$  are given in Figure 4.

As described above, if we compose both models we can merge initial and maximal events for shared

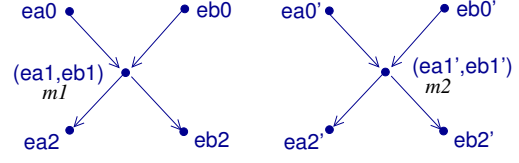

Figure 4: Model for  $SD_1$  (left) and  $SD_2$  (right).

objects which in this case corresponds to events  $e_{a0}$  and  $e_{a0'}$ ,  $e_{b0}$  and  $e_{b0'}$ ,  $e_{a2}$  and  $e_{a2'}$ , and  $e_{b2}$  and  $e_{b2'}$ . The final composition  $SD_1 \parallel SD_2$  is shown in Figure 5. This is the exact model obtained for a sequence dia-

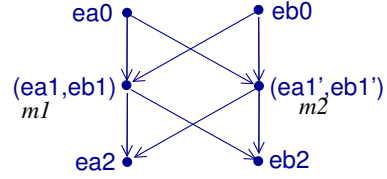

Figure 5: Model for  $SD_1 \parallel SD_2$ .

gram which consists of a parallel fragment with two operands where the first operand is taken from  $SD_1$  and the second operand is taken from  $SD_2$ .

The composition of diagrams  $SD_1$  and  $SD_2$  with *shared behaviour* is written  $SD_1 \parallel_G SD_2$  where  $G = Mes_1 \cap Mes_2$  indicates the shared behaviour.

If  $G = Mes_1$ , in other words, all the behaviour in  $SD_1$  is shared, then we say that  $SD_1$  is *syntactically contained* in  $SD_2$ , and the composition  $SD_1 \parallel_G SD_2$  can be reduced to  $SD_2$ .

We now consider the case that  $G = \{m\}$ . This case can be generalised to a finite number of messages, but we omit it here for simplicity.

Consider  $SD_1 = seq(\varphi_0, m, \varphi_1)$  and  $SD_2 = seq(\varphi_0', m, \varphi_1')$  where  $seq$  denotes a sequential fragment,  $\varphi_0, \varphi_1, \varphi_0'$  and  $\varphi_1'$  are interactions which on their own would define a valid sequence diagram and may be empty. The composition  $SD_1 \parallel_G SD_2$  is defined syntactically by  $seq(par(\varphi_0, \varphi_0'), m, par(\varphi_1, \varphi_1'))$ .

Note that the  $seq$  fragment describes the default (sequential) behaviour of a sequence diagram and can be omitted in a diagram, but is useful here to describe composition in general. For example,  $SD_1$  from Figure 3 can be seen as  $seq(\varphi_0, m_1, \varphi_1)$  with  $\varphi_0$  and  $\varphi_1$  both empty.

Consider a more complex case where  $SD_1 = f(seq(\varphi_0, m, \varphi_1), \varphi_2)$  and  $SD_2 = seq(\varphi_0', m, \varphi_1')$  where  $f$  denotes an arbitrary fragment (e.g., *par*, *alt*, etc). The composition  $SD_1 \parallel_G SD_2$  is defined syntactically by  $f(seq(par(\varphi_0, \varphi_0'), m, par(\varphi_1, \varphi_1')), \varphi_2)$ . In other words, if the shared behaviour is contained in an arbitrary fragment, then this fragment is preserved in the composed behaviour.

Consider the sequence diagrams  $SD_1$  and  $SD_2$  given in Figure 6 which share message  $m_2$ .

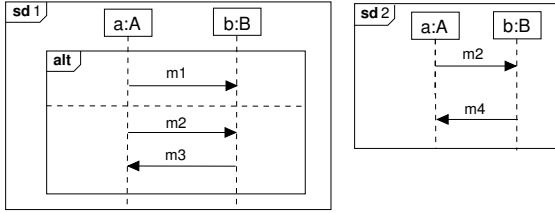

Figure 6: Two sequence diagrams with shared message  $m_2$ .

The sequence diagrams can be seen as  $SD_1 = alt(\varphi_0, seq(\emptyset, m_2, \varphi_1))$  and  $SD_2 = seq(\emptyset, m_2, \varphi_1')$ , with  $\varphi_0$  corresponding to a simple interaction with  $m_1$ , and similarly for  $\varphi_1$  and message  $m_3$ , and  $\varphi_1'$  and message  $m_4$ . The composition  $SD_1 \parallel_G SD_2$  as outlined above is given by  $alt(\varphi_0, seq(\emptyset, m_2, par(\varphi_1, \varphi_1')))$ . The composed diagram is our first sequence diagram from Figure 1.

Given the syntactic composition of two sequence diagrams we derive the model (a labelled event structure) as described before.

## 4 MODEL TRANSFORMATION TO ALLOY

We implement our composition method with the help of MDA techniques (Kleppe et al., 2003). Due to space restrictions, we only discuss the transformation rules in this paper. These rules can be implemented via any MDA transformation engine. We now give an overview of the transformation rules from sequence diagrams to Alloy. Our approach is such that if an Alloy model can be solved, it generates all possible solutions each of which corresponds to a run of the original sequence diagram and in accordance to the formal semantics defined in the previous sections. Three transformation rules are defined and described below.

### 4.1 Lifeline and message

Each lifeline in a sequence diagram, which corresponds to an object with a name and type (class), must be transformed into Alloy code.

```

1 abstract sig Lifeline {}
2 one sig A{} //lifeline Class
3 one sig a {} //Lifeline name
4 one sig Lifeline_1 extends Lifeline {
5   name: a,
6   type: A }

```

The code above shows an example of a lifeline declaration in Alloy. In line 1, `abstract sig` represents the definition of an abstract signature for Lifeline which can then be extended later by concrete lifelines from a sequence diagram. Line 4 gives a concrete lifeline declaration `Lifeline_1`. The keyword `one` in the declaration indicates that there is exactly one instance of the signature. Furthermore, a lifeline signature has two fields: `name` to specify the object name, and `type` to specify its class.

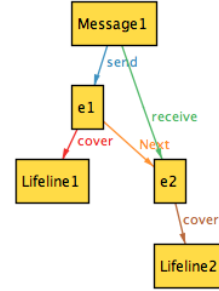

Figure 7: Message representation in an Alloy instance.

The transformation of a message into Alloy code maps the message components (message name and corresponding send and receive events) to corresponding signatures in Alloy also making appropriate connections to the lifelines of the sender and receiver objects (see Figure 7).

In the code, the transformation creates an abstract signature `Message` which consists of a send and receive Event, also a defined abstract signature. In our example, events `e1` and `e2` are declared in lines 7-10. Additionally, for each message we need to define the order of occurrence of its respective send and receive events. In Alloy, this is given by a logical constraint `fact messageEventsOrder`, which in this case specifies that for all messages, the send event always happens before the receive event.

```

1 abstract sig Event {NEXT :set Event}
2 abstract sig Message{send: Event,
3   receive: Event}
4 one sig M1{} //Message name
5 one sig message extends Message{
6   NAME: M1,} //Message declaration
7 one sig e1 extends Event{
8   COVER: Lifeline_1} //Event declaration
9 one sig e2 extends Event{
10  COVER: Lifeline_2}
//assigning events to their message
11 fact {
12  e1 in message.send
13  e2 in message.receive
//message send before receive
14 fact messageEventOrder{
15  all M: Message | M.receive in M.send.NEXT}

```

In general, a sequence diagram contains several messages. In case of a basic sequence diagram without interaction fragments, this implies a total order along the events of the lifeline of an object. This is specified in Alloy by another logical constraint called `fact generalOrder` which specifies the order in which all messages and their underlying events occur along the lifelines of the corresponding object instances.

```
//general order
fact generalOrder {
  e2 in e1.NEXT
  e4 in e3.NEXT}
```

In the example above, the fact specifies that `e2` occurs after `e1` (it is in a relation `NEXT` with `e1`), and `e4` occurs after `e3`. Nothing is said about the relation between `e2` and `e4`.

## 4.2 Parallel Combined Fragment

For the parallel interaction fragment (also called combined fragment in accordance to the UML metamodel (OMG, 2011)), the transformation generates a set of abstract signatures as can be seen in lines 1-3 of the code fragment below.

```
1 abstract sig Combinedfragment {
2   cover:set Operand}
3 abstract sig Operand{cover:set Event}
4 one sig CF_TYPE_PAR {}//Combinedfragment Type
5 one sig CF extends Combinedfragment{
6   TYPE = CF_TYPE_PAR}
7 one sig Operand_1 extends Operand{}
8 one sig Operand_2 extends Operand{}
// Covering: Combined Fragment->Operands
9 fact{
10  Operand_1 in CF.cover
11  Operand_2 in CF.cover}
.....
12 fact{all CF: Combinedfragment,
13   OP1: CF.cover, OP2: CF.cover,
14   E1: OP1.cover,E2: OP2.cover,
15   E3: OP1.cover |
16   no E4: OP2.cover | OP1 != OP2
17   and E2 in E1.NEXT
18   and E3 in E4.NEXT }
```

Each of these abstract signatures represents the main elements in the metamodel of the combined fragment. `sig CF_TYPE_PAR` in line 4 declares the type of the combined fragment, in this case a `PAR`. Following this, in lines 7 and 8, two signatures define the number of operands used, in this case `Operand_1` and `Operand_2`. The fact in line 9 connects the parallel fragment with its operands. Each operand covers the send and receive events of the messages defined inside it. Finally, the Alloy model that contains a parallel combined fragment must show a parallel execution of

`operand_1` and `operand_2`, in other words, the events covered by each operand are not related by `NEXT` and can thus occur in an arbitrary order. This is given in the fact of line 12, and is in accordance to the labelled event structure semantics given earlier. It implies a relation of concurrency between events in different operands whilst the events within an operand remain ordered in the usual way. Therefore, this fact guarantees the preservation of the correct and intended order of events in a parallel fragment.

## 4.3 Alternative Combined Fragment

In Alloy code, the representation of an alternative combined fragment is similar to that of a parallel combined fragment with an additional constraint to preserve the semantics as can be seen below.

```
// alt: exact one operand will be executed
fact{all CF: Combinedfragment |
 ( CF.TYPE = CF_TYPE_ALT) => # CF.cover = 1}
```

The fact above defines that at most one operand is executed. This implies that a different set of events occurs for each possible run of the code.

## 5 COMPOSITION VIA ALLOY

In order to compose Alloy models that have been obtained by transformation from sequence diagrams, two fundamental conditions must be satisfied:

- *Matching* elements must indicate correspondence between equivalent elements of the source. The purpose of matching is to uncover how two models correspond to each other.
- *Merging* of equivalent elements identified earlier producing a composed version of the models.

In Alloy, these conditions can be encoded by adding facts that must be satisfied to match and merge equivalent elements. For example, consider two Alloy models `A1` and `A2` each with two lifelines, where these lifelines have the same name and type. In order to compose the lifelines with the same name from each one of the models we have to specify the fact below.

```
fact lifelineEquality {
all L1: A1_lifeline_1 , L2: A2_lifeline_1 |
(L1.type=L2.type && L1.name=L2.name) =># L2 =0}
```

The Alloy code above shows that if the matching condition is satisfied, then lifelines will be merged into one which is `L1` (and `L2` will be hidden). The same is true of messages. For example, if the two Alloy models `A1` and `A2` have two messages, and these

messages have the same name, send and receive from the same lifelines, then Alloy will compose these messages into one.

The idea of the procedure of merging entered models in Alloy is as follows. First we generate a new Alloy model  $A_3$  representing the result of merging the original models. Second, we copy all the elements of  $A_1$  to  $A_3$ . Third, we copy all elements of  $A_2$  except the duplication elements such as abstract signatures that are shared in the two models. Fourth, for any pair of equal elements, one of the signatures keyword has to be changed from `one` to `lone` to be able to merge it and then add the merging facts mentioned above. Finally, in terms of merging messages, the merged message events (send and receive) are replaced with their equivalent message events to apply the behaviour environment of both models into this message.

To validate our approach, we implemented the example of Figure 6 in Alloy. After solving the merged model, we obtained three Alloy solutions (also referred to as instances). These instances show exactly the expected behaviour underlying Figure 1 with possible traces of execution: only  $m_1$  occurs, or  $m_2 \cdot (m_3 \text{ co } m_4)$  occur. Figure 8 shows two Alloy

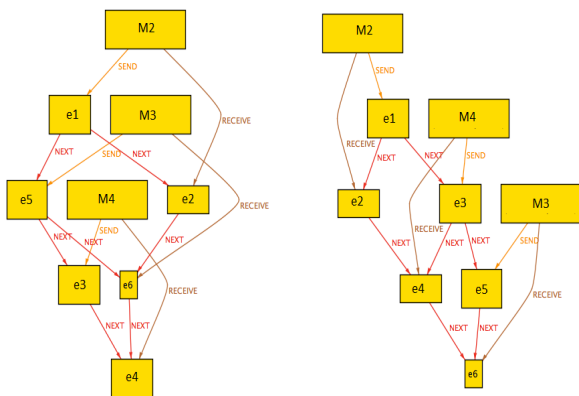

Figure 8: Alloy instance of merging the diagrams from Figure 6

instances, one for each of the possible executions of the second operand of the alternative fragment. These instances show in particular that  $m_2$  is always before  $m_3$  and  $m_4$ , and  $m_3$  and  $m_4$  are in parallel.

We have recently developed an Eclipse plugin called *SD2Alloy* which implements the above approach. The tool uses MDA (Kleppe et al., 2003) to transform two sequence diagrams and combine them as depicted in Figure 9. The figure outlines the *SD2Alloy* architecture. The tool parses XMI files exported from the UML tool Papyrus (Lanusse et al., 2009) into sequence diagram Java objects using the UML2 library. SiTra (Akehurst et al., 2006) is used

to transform the Java objects of sequence diagrams and create the Alloy Java object that produces the Alloy code. Moreover, this tool allows the user to specify composition constraints (merging glue) required in Alloy to merge the entered models.

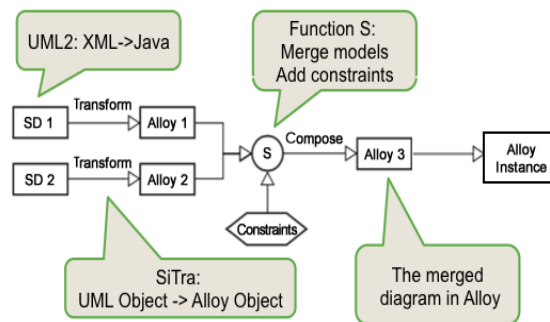

Figure 9: The SD2Alloy architecture

## 6 RELATED WORK

Over the last decade, a number of software tools and algorithms have been designed and implemented to compose behavioural models. Liang et al. (2008), have presented a method of integrating sequence diagrams based on the formalisation of sequence diagrams as typed graphs. Rubin et al. (2008), illustrate the use of the Alloy Analyzer to compose class diagrams based on syntactic properties of meta-models and the primary model. This approach uses UML2Alloy (Anastasakis, K et al.) to transform UML class diagrams into Alloy and Alloy Analyzer to compose these classes. However, their method only composes static models and the compositional code produced is generated manually.

In addition, Widl et al. (2013) present an approach for composing concurrently evolved sequence diagrams in accordance to the behaviour given in state machine models. They describe the problem of merging sequence diagrams formally using SAT solvers. However, similarly to Liang et al. (2008), the approach does not merge complex sequence diagrams.

When looking at the integration of several model views or diagrams, Küster-Filipe and Bordbar (2007) present a method of mapping a design consisting of class diagrams, OCL constraints and sequence diagrams into a mathematical model for detecting and analysing inconsistencies. Finally, Araújo et al. (2004) propose a further approach to composition of sequence diagrams by composing sequence diagram operators directly. This approach is very different



from ours and can be seen as a high-level composition strategy at the UML level.

## 7 CONCLUSIONS

In this paper, we have defined a new compositional semantics of sequence diagrams based on the true-concurrent model of labelled event structures, and presented an automated technique based on Alloy that relies on the true-concurrent semantics.

The underlying developed tool takes as an input one or more sequence diagrams, and automatically constructs Alloy solutions for the composition. Each of the solutions corresponds to a run that can be derived from the underlying labelled event structure of the composed sequence diagram. Our approach has been evaluated through a series of examples and larger case studies.

The composition as defined in this paper assumes a diagram as representing *possible* but not mandatory behaviour. It is our intention to extend this view to a more flexible approach which enables designers to choose between *must* and *may* interactions. An extension of our formal framework and consequent translation to Alloy to cover both options is subject to further work, as is an extension to more complex features from sequence diagrams in Alloy.

## REFERENCES

- Akehurst, D., Bordbar, B., Evans, M., Howells, W., and McDonald-Maier, K. (2006). SiTra: Simple transformations in Java. In *MoDELS'06*, LNCS 4199, pages 351–364. Springer.
- Araújo, J., Whittle, J., and Kim, D. (2004). Modeling and composing scenario-based requirements with aspects. In *RE 2004*, pages 58–67. IEEE.
- Berre, D. L. and Parrain, A. (2010). The SAT4j library, release 2.2 - system description. *Journal on Satisfiability, Boolean Modeling and Computation*, 7:59–64.
- Anastasakis, K., Bordbar, B., Georg, G., and Ray, I. (2007). UML2Alloy: A challenging model transformation. In *Model Driven Engineering Languages and Systems*, pages 436–450. Springer.
- Harel, D. and Marelly, R. (2003). *Come, Let's Play: Scenario-based Programming Using LSCs and the Play-Engine*. Springer.
- Jackson, D. (2006). *Software Abstractions: logic, language and analysis*. MIT Press.
- Kleppe, A., Warmer, J., and Bast, W. (2003). *MDA Explained: The model driven architecture: practice and promise*. Addison-Wesley.
- Küster-Filipe, J. (2006). Modelling concurrent interactions. *Theoretical Computer Science*, 351:203–220.
- Küster-Filipe, J. and Bordbar, B. (2007). A formal model for integrating multiple views. In *ACSD 2007*, pages 71–79. IEEE.
- Lanusse, A., Tanguy, Y., Espinoza, H., Mraidha, C., Gerard, S., Tessier, P., Schnekenburger, R., Dubois, H., and Terrier, F. (2009). Papyrus UML: an open source toolset for MDA. In *ECMDA-FA 2009*, pages 1–4.
- Liang, H., Diskin, Z., Dingel, J., and Posse, E. (2008). A general approach for scenario integration. In *MoDELS'08*, LNCS 5301, pages 204–218. Springer.
- Micskei, Z. and Waeselynck, H. (2011). The many meanings of UML 2 sequence diagrams: a survey. *Software and Systems Modeling*, 10:489–514.
- OMG (2011). *UML: Superstructure. Version 2.4.1*. OMG, <http://www.omg.org>. Document id: formal/2011-08-06. [accessed 1-6-2012].
- Rosa, M. L., Dumas, M., Uba, R., and Dijkman, R. (2010). Merging business process models. *On the Move to Meaningful Internet Systems: OTM 2010*, pages 96–113.
- Rubin, J., Chechik, M., and Easterbrook, S. (2008). Declarative approach for model composition. In *MiSE'08*, pages 7–14. ACM.
- Widl, M., Biere, A., Brosch, P., Egly, U., Heule, M., Kappel, G., Seidl, M., and Tompits, H. (2013). Guided merging of sequence diagrams. In *SLE 2012*, LNCS 7745, pages 164–183. Springer.
- Winskel, G. and Nielsen, M. (1995). Models for Concurrency. In Abramsky, S., Gabbay, D., and Maibaum, T., editors, *Handbook of Logic in Computer Science, Vol. 4, Semantic Modelling*, pages 1–148. Oxford Science Publications.