

Field Investigation and Parametric Study of Greenhouse Gas Emission from Railway Plain-Line Renewals

Krezo, Steven; Mirza, Olivia ; He, Yaping; Makim, Polly; Kaewunruen, Sakdirat

DOI:
[10.1016/j.trd.2015.10.021](https://doi.org/10.1016/j.trd.2015.10.021)

License:
Creative Commons: Attribution-NonCommercial-NoDerivs (CC BY-NC-ND)

Document Version
Peer reviewed version

Citation for published version (Harvard):
Krezo, S, Mirza, O, He, Y, Makim, P & Kaewunruen, S 2016, 'Field Investigation and Parametric Study of Greenhouse Gas Emission from Railway Plain-Line Renewals', *Transportation Research Part D: Transport and Environment*, vol. 42, pp. 77-90. <https://doi.org/10.1016/j.trd.2015.10.021>

[Link to publication on Research at Birmingham portal](#)

Publisher Rights Statement:

After an embargo period this document is subject to the terms of a Creative Commons Attribution Non-Commercial No Derivatives license

General rights

Unless a licence is specified above, all rights (including copyright and moral rights) in this document are retained by the authors and/or the copyright holders. The express permission of the copyright holder must be obtained for any use of this material other than for purposes permitted by law.

- Users may freely distribute the URL that is used to identify this publication.
- Users may download and/or print one copy of the publication from the University of Birmingham research portal for the purpose of private study or non-commercial research.
- User may use extracts from the document in line with the concept of 'fair dealing' under the Copyright, Designs and Patents Act 1988 (?)
- Users may not further distribute the material nor use it for the purposes of commercial gain.

Where a licence is displayed above, please note the terms and conditions of the licence govern your use of this document.

When citing, please reference the published version.

Take down policy

While the University of Birmingham exercises care and attention in making items available there are rare occasions when an item has been uploaded in error or has been deemed to be commercially or otherwise sensitive.

If you believe that this is the case for this document, please contact UBIRA@lists.bham.ac.uk providing details and we will remove access to the work immediately and investigate.

1
2
3
4
5
6
7
8
9
10
11
12
13
14
15
16
17
18
19
20
21
22
23
24
25
26
27
28
29
30
31
32
33
34
35
36
37
38
39
40
41
42
43
44
45
46
47
48
49
50
51
52
53

REVISED TECHNICAL PAPER

**“Field Investigation and Parametric Study of Greenhouse Gas
Emission from Railway Plain-Line Renewals”**

(Title contains 13 words)

by

Steve Krezo

School of Computing, Engineering & Mathematics
University of Western Sydney

Olivia Mirza

School of Computing, Engineering & Mathematics
University of Western Sydney

Yaping He

School of Computing, Engineering & Mathematics
University of Western Sydney

Polly Makim

School of Computing, Engineering & Mathematics
University of Western Sydney

Sakdirat Kaewunruen

Sydney Trains – Track Engineering
Level 13, 477 Pitt St, Sydney NSW 2000 Australia

Submitted to

Transportation Research Part D

Corresponding Author:

Sakdirat Kaewunruen
Senior Lecturer in Railway Engineering
Birmingham Center for Railway Research and Education
University of Birmingham
Birmingham, B15 2TT, UK
Tel: 02 89221151
E-mail: sakdirat@hotmail.com

Manuscript Summary:

Total pages	30 (including 1-page cover)
Number of figures	4
Number of tables	6

Field Investigation and Parametric Study of Greenhouse Gas Emission from Railway Plain-Line Renewals.

Steven Krezo¹, Olivia Mirza², Yaping He³, Polly Makim⁴, Sakdirat Kaewunruen⁵.

Abstract

Railway transportation is becoming increasingly important in many parts of the world for mass transport of passengers and freight. This study was prompted by the industry's need to systemically estimate greenhouse gas emissions from railway construction and maintenance activities. In this paper, the emphasis is placed on plain-line railway maintenance and renewal projects. The objective of this study was to reduce the uncertainties and assumptions of previous studies based on ballasted track maintenance and renewal projects. A field-based data collection was carried out on plain-line ballasted track renewals. The results reveal that the emissions from the materials contribute more than nine times the CO₂-e emissions than the machines used in the renewal projects. The results show that extending the lifespan of rail infrastructure assets through maintenance is beneficial in terms of reducing CO₂-e emissions. Analysis was then carried out using the field data. Then the results were compared to two ballastless track alternatives. The results show that CO₂-e emissions per metre from ballasted track were the least overall, however, the maintenance CO₂-e emissions are greater than those of ballastless tracks over the infrastructure lifespan, with ballasted track maintenance emitting more CO₂-e emissions at the 30 and 60 year intervals and the end of life when compared to the ballastless track types. The outcome of the study can provide decision makers, construction schedulers, environmental planners and project planners

¹ Phd Candidate, School of Computing, Engineering & Mathematics, Western Sydney University, Kingswood, NSW Australia. E-mail: S.Krezo@uws.edu.au

² Senior Lecturer, School of Computing, Engineering & Mathematics, Western Sydney University, Kingswood, NSW Australia. E-mail: O.Mirza@uws.edu.au

³ Director of Academic Programme, School of Computing, Engineering & Mathematics, Western Sydney University, Kingswood, NSW Australia. E-mail: Y.He@uws.edu.au

⁴ Master of Engineering Candidate, School of Computing, Engineering & Mathematics, Western Sydney University, Kingswood, NSW Australia. E-mail: 17875602@student.uws.edu.au

⁵ Corresponding Author. Senior Lecturer in Railway and Civil Engineering, Birmingham Centre for Railway Research and Education, University of Birmingham, Birmingham, B15 2TT, UK. E-mail: sakdirat@hotmail.com

78 with reasonably accurate GHG emission estimates that can be used to plan, forecast and reduce
79 emissions for plain-line renewal projects.

80

81 **Keywords:** railway maintenance, track beds, greenhouse gas emissions, random, uncertainty.

82

83 **Nomenclature**

84 C_i energy content factor of type i fuel (GJ/kL).

85 CO₂-e carbon dioxide and equivalents, including CO₂, CH₄, N₂O and synthetic gases.

86 E_{CM} CO₂-e emission per unit track length for construction machinery (kg/m).

87 EF_k the embodied emissions factor for type k material (kg/kg).

88 E_{IC} CO₂-e emissions per unit of track length for the initial construction (kg/m).

89 E_{ij} amount of emission of gas species j relating to fuel i (kg).

90 E_l CO₂-e emission per unit track length per year of lifespan (kg/m.year).

91 E_m CO₂-e emission due to maintenance per unit track length (kg/m).

92 EM embodied CO₂-e emissions per unit track length (kg/m).

93 EM_{ic} CO₂-e emission per unit track length for materials used in initial construction (kg/m).

94 EM_r CO₂-e emission per unit track length for materials used in renewals and maintenance
95 activities (kg/m).

96 E_u CO₂-e emission per metre of track from ballasted track maintenance activities (kg/m).

97 F_{ij} emission factor for gas j by fuel i (kg/GJ).

98 L lifespan, or the time period of construction and operation phases of the lifecycle (year).

99 M types of maintenance activities.

100 MF maintenance frequency.

101 N total number of material types used in track construction.

102 Q_i quantity of type i fuel (kL).

103 QM_k quantity of material k required per meter of track construction (kg/m).

104 T track length processed in a renewal maintenance project (m).

105 Subscript

106 i, j, k fuel, gas species and material indices

107 n maintenance activity index

108

109 **1 Introduction**

110 Rail transportation is becoming ever more attractive especially in Europe, Japan and Asia. In
111 Australia, the railway infrastructure is built to carry either passengers or freight, or both, uni- and
112 bi-directionally (Remennikov and Kaewunruen, 2014), and the nation's heavy haul rail network is
113 one of the world's best and most efficient transport systems (Kaewunruen and Remennikov, 2010).
114 The railway track (also called 'railroad' in the US) is a complex system built upon many supporting
115 elements within the track corridors. The operational and logistic point of view adds another layer of
116 the complexity. Railway infrastructure is constructed to have a design life ranging from 10 years to
117 100 years, depending on construction type (ballasted or ballastless), construction materials, loading
118 and weathering conditions. Throughout this period, maintenance and renewals of aged components
119 are required to assure the safety and reliability of the rail network for passengers and cargo
120 (Remennikov and Kaewunruen, 2008; Kaewunruen et al., 2015).

121 In general, there are two types of railway infrastructure: ballasted and ballastless tracks.
122 Ballasted track is laid on crushed aggregates and capping layers that are placed on the formation,
123 with the combination commonly referred to as the 'substructure'. It supports a combination of
124 sleepers, rails and fixings which is commonly referred to as the 'superstructure' (Manalo et al.,
125 2010; Burrow et al., 2007). Ballastless track uses a concrete slab system and special fixings to
126 support the steel rails which transfer the loads from passing trains to the concrete slab. Michas
127 (2012) explains that ballastless track is superior to ballasted track due to its higher stability, less
128 frequent maintenance, reduced height and longer lifecycle. The disadvantages of ballastless track
129 are inflexibility and higher initial construction costs due to the increased concrete and steel content.

130 Ballasted track has been used since the early 1800's and is still very common but the popularity of
131 ballastless track has increased over the last 40 years (Michas, 2012).

132 In recent decades, the issue of greenhouse gas (GHG) emissions in railway systems has
133 attracted much attention in response to the concern created by climate change (Schwarz, 2009).
134 The impact of railway systems on the global environment is becoming a more and more important
135 part of their life cycle analysis (Chester and Horvath, 2009). Inevitably, the decision on the choice
136 of track type in railway construction projects will depend on the outcome of greenhouse gas
137 emission analysis as well as on social, economic and other environmental considerations. This has
138 prompted investigations into the GHG emissions from the construction and maintenance of track
139 beds (Kiani et al., 2008; Milford and Allwood, 2010; Chang and Kendall, 2011; Schwarz, 2009;
140 Chester and Horvath, 2011; Ueda et al., 2008).

141 The planning and design are the first steps in developing a railway system. Some major
142 considerations include construction type, track characteristics, routes and intended use.
143 Construction follows and with the assistance of diesel engine driven machines, a reduced timeframe
144 can be achieved. Once construction of the railway is complete, the railway becomes operational.
145 Maintenance is then carried out for the railway's lifespan as it is crucial to ensure the track system
146 operates successfully. Maintenance and renewal of ballasted track bed includes ballast resurfacing
147 (ballast tamping, regulating and stabilising), rail grinding, ballast cleaning, continuous track
148 renewals and switch renewals, with all these activities relying on diesel engine driven machines to
149 reduce the timeframe and increase the scope of maintenance. The end of life activities include the
150 demolition and recycling of materials. An illustration of the railway system and inclusions of the
151 current study are shown in Figure 1a.

152 The findings of the literature review show that some of the previous studies had relied on
153 machinery assumptions which were not verified. Some of the assumptions were believed to have
154 led to the greatest case scenario in GHG emissions estimating.

155 This study has been conducted with the objective to reduce the uncertainties and
156 assumptions of previous studies by carrying out a field based data collection of railway maintenance
157 and renewal activities and report on the CO₂-e activities from railway maintenance. The objective
158 of the parametric study is to estimate the CO₂-e emissions from the maintenance of ballasted and
159 ballastless track, by providing a comparison in a unit length of measurement. The results are then
160 used to estimate CO₂-e emissions from railway maintenance in emissions forecasting. The outcome
161 of the study can provide decision makers, construction schedulers and project planners with
162 reasonably accurate GHG emission estimates that can be used to plan, forecast and reduce
163 emissions for plain-line renewal projects.

164

165 **2 Greenhouse Gas Emissions and Life Cycle of Plain-line Railway**

166 **2.1 Maintenance and Life Cycle of Plain-line Railway**

167 In Australia, the most commonly used type of track form is ballasted track. Ballasted track is
168 preferred due to the low initial cost, ease of renewal and maintenance, and the availability of
169 materials (Kaewunruen et al., 2011a, 2011b, 2014). Esveld (2003) suggests that, while ballastless
170 track is more expensive to construct, its reduced long-term maintenance is a desirable characteristic
171 for train lines with limited maintenance possession times. Rheda (2000) also claims that ballastless
172 track systems are capable of carrying increased axle loads, operation at faster speeds, require little
173 track bed maintenance and have an increased service life.

174 Track replacement occurs as a periodic maintenance activity. Ballasted track (with concrete
175 sleepers) is designed to last 10 to 100 years (Kaewunruen and Remennikov, 2008); however,
176 increased rail traffic, poor maintenance practices and material degradation can result in reduced life
177 of the track. Alternatively, high quality initial construction, efficient and frequent maintenance and
178 low traffic loads can result in an increased lifespan.

179 Ballasted track resurfacing is the process of removing voids from aggregates in the track
180 bed. It comprises of three activities: tamping, regulating and stabilising which occur in ballasted

181 track only. Tamping corrects track geometry by packing the aggregates whilst lifting and lining the
182 track; ballast regulating returns the aggregates and reinstates shoulder widths; and stabilising
183 compacts the aggregates to ensure uniformity and compaction in the ballast region.

184 Rail head grinding and rail replacement are also important maintenance activities. Rail head
185 grinding is a corrective maintenance activity that removes surface corrosion and cracking from the
186 rail head and restores the rail profile. Studies on rail head grinding have found that the life of the
187 rail can be extended by routinely undertaking this activity. Rail lines without regular grinding have
188 a higher risk of rail breakage (Podofillini et al., 2006). Rail replacement is required when the rail is
189 worn down to an unacceptable depth. Typical steel rail sections are expected to last in excess of 45
190 years in Europe or sometimes over 75 years in Australia, depending on loading and site conditions
191 (Girsch et al., 2008; Kaewunruen et al., 2014; 2015). Increased rail deterioration is caused by tight
192 curve radii's, increased traffic loads and lack of maintenance (Correa et al., 2011).

193 Ballastless track systems are widely available and, as Michas (2012), explained there are 34
194 varieties of ballastless track bed which vary in design and are constructed to suit different
195 topography and technological factors. For the purpose of a parametric study, the results from Kiani
196 et al. (2008) have been chosen to compare the ballasted track bed and ballastless track systems and
197 show the impact of track bed choice on future maintenance CO₂-e emissions.

198

199 **2.2 Research on Greenhouse Gas Emissions**

200 Greenhouse gas is a collection of gases that produce a greenhouse effect in the atmosphere.
201 These gases include CO₂, CH₄, N₂O, HFCs, SF₆, CF₄ and C₂F₆. They are denoted as CO₂-e, which
202 is defined by DOE (2014) as carbon dioxide equivalent.

203 The transportation sector globally is responsible for 13 % of total CO₂-e emissions, (Rao
204 2009). The importance of investigating the environmental impact of track bed selection has
205 increased, with decision makers and planners required to assess many factors when selecting track

206 construction type. The maintenance of the railway is vital in ensuring the reliability and longevity of
207 the infrastructure and needs to be considered in lifecycle studies.

208 Remennikov and Kaewunruen (2008) explained that components in plain-line tracks
209 experience considerably less wear and tear or damage when compared with special track
210 components, such as turnouts, diamonds or crossovers. However, plain-line railway track
211 components deteriorate faster in tight curves, under heavy axle loads and in adverse weather
212 conditions. Hence more frequent maintenance is required for such sections and conditions (Lewis
213 and Olofsson, 2004).

214 A critical literature review was carried out on the maintenance and construction activities
215 of ballasted and ballastless track beds in this study. A study by Milford and Allwood (2010)
216 assessed the current and future impacts of track bed types in the UK rail network. The authors
217 found that in the UK, maintenance and replacement of rail components emitted between 430 and
218 934 thousand tonnes of CO₂ annually for 33,500 kilometres of railway track. The biggest
219 contribution to CO₂ emissions was from steel rail manufacture (it is noted that the study only
220 considered carbon dioxide emissions). Since the steel rail component of a railway track system
221 was the highest contributor to GHG emissions, the authors investigated future track designs of
222 quadruple and double headed rail, with the findings showing that GHG emissions could be
223 reduced by 40 % if the rail could be reused instead of replaced. Whilst the study considered the
224 whole lifecycle, the maintenance CO₂ emissions reporting was difficult as there was no
225 published literature at the time, therefore, estimates were used for machinery fuel consumption,
226 renewal and maintenance frequencies, construction speeds and maintenance data.

227 Swartz (2009) reported on the environmental impact of high speed rail construction in
228 Europe. The author found that the track bed selection and the share of bridges and tunnels have
229 the greatest impact on the overall CO₂-e emissions. The study by Swartz (2009) primarily
230 concentrated on the construction and the operation of track infrastructure.

231 Lee et al. (2008) investigated the lifecycle of ballasted and ballastless slab track with a
232 focus on sustainable track construction. The authors found that ballasted track had a higher
233 energy consumption than ballastless slab track. They suggested that more emphasis be placed on
234 the environmental effectiveness of railway transportation and that lifecycle analysis tools be
235 applied to reduce environmental burdens.

236 The maintenance phase is an integral part of the lifecycle of railway systems. The level of
237 use of machinery is an important factor in the generation of CO₂-e emissions in track bed
238 maintenance. An investigation of the CO₂-e emissions from new high speed rail infrastructure
239 construction in the USA was carried out by Chang and Kendall (2011). The authors found that
240 the construction of bridges and tunnels contributed over 60 % of the total CO₂-e emissions from
241 construction, with the tunnels and bridges occupying only 15 % of the total length of the project.
242 The study concluded that the machines used in initial construction contributed 5 % of total CO₂-e
243 emissions as compared to 80 % from the emission embodied in the materials. The authors
244 concentrated on the construction of new rail infrastructures and excluded the maintenance phase.

245 Ueda et al. (2003) assessed the lifecycle of Shinkansen trains and sleepers in Japan. The
246 authors found that timber sleepers emit the least CO₂-e compared with concrete, steel and
247 synthetic sleepers. The authors did not investigate the impact of renewing the sleepers or the
248 methodologies of renewals or maintenance.

249 Ballasted track has higher CO₂-e emissions from maintenance as the crushed aggregate
250 requires increased maintenance compared to a ballastless track systems. Ballast cleaning and
251 replacement involves replacing the crushed aggregates due to deterioration from cyclic loadings,
252 fouling of the capping layer/ballast section or inadequate maintenance (Indraratna, 2009).

253 Von Rozycki et al. (2003) investigated the Hanover-Wuerzburg high speed rail line to
254 determine the energy consumption of resources over the whole network including construction,
255 vehicle manufacturing, maintenance, stations and train retrofitting. The authors found that the
256 cumulative energy demand (defined as “the end material and end energy consumption to the

257 primary energy drawn from nature at any stage of its lifecycle”) of the infrastructure construction
258 was responsible for 13 % of the total energy consumption. More importantly, it was found that
259 the CO₂-e emissions associated with the material requirements for the Rheda ballastless track
260 systems did not consume more energy than the ballasted track systems, as the extended life of
261 ballastless track systems (60 year lifecycle) offsets the higher initial construction CO₂-e
262 emissions, which results from the increased concrete requirement in ballastless track. This
263 finding was confirmed by Kiani et al. (2008), who conducted an investigation into the lifecycle
264 of both ballasted and ballastless track beds. The authors found that ballastless track was not
265 associated with higher CO₂-e emissions. Because limited data was available at the time of
266 publishing, the authors based their study on assumed maintenance intervals, fuel consumptions
267 and construction speeds. Recognising that some of the assumptions considered a best case
268 scenario and would not be practical for estimating much shorter renewal or maintenance
269 projects, the authors made particular recommendations on further investigations into the fuel
270 consumption of machinery used in construction and maintenance.

271 In summary, limited maintenance data has been published in the literature, with the use
272 of assumptions to yield high level estimates. In order to verify the assumptions used in lifecycle
273 emissions reporting, systematic first hand data collection and analysis are needed.

274

275 **3 Methodology**

276 **3.1 Overview**

277 The objective of the current study is to estimate the CO₂-e emissions during the plain-line
278 railway maintenance phase and compared with that during the construction phase (Figure 1a). Focus
279 is given to the collection and analysis of the CO₂-e emissions associated with the maintenance
280 activities of ballasted track, due to the preference for ballasted track throughout Australia and the
281 availability of appropriate sites. The data was collected from the field through interviews with
282 construction managers, engineers and specialists and onsite observations, including assessment of

283 cross sections, fuel consumptions, material lengths and lifespans, field based observations and
284 construction methodologies. The results are compared to ballastless track systems from a previous
285 study conducted by Kiani et al. (2008). A parametric study is then conducted to assess and forecast
286 CO₂-e emissions from renewal projects by examining different track life scenarios and maintenance
287 intervals.

288 The field based study did not include the analysis of CO₂-e emissions from the embodied
289 emissions from the initial construction and earthworks, transportation and removal of materials, fuel
290 from employees travelling to site, timber sleepers, disposal and the recycling of materials,
291 calculation of the residual impact of the materials removed from the renewals and the
292 manufacturing of the machines used in construction or maintenance. The scope of the current study
293 is illustrated in Figure 1b.

294 Data collection was carried out on ballasted track renewal projects to evaluate the associated
295 CO₂-e emissions associated with maintenance and renewal management practice and processes. The
296 projects surveyed varied in difficulty and track length to ensure that a diverse range were captured
297 for analysis.

298

299 **3.2 Collection of Maintenance Project Management Data**

300 All projects were carried out during weekend possession shutdowns. The maximum
301 possession time is 50 hours; however, projects are usually completed well before the maximum
302 time. Machines are delivered to site (applicable if machines are not road-worthy) and then remain
303 on-site until the scheduled completion of tasks. All projects utilised small excavators and front end
304 loaders until the completion of the works, all other machines were required for specific tasks only,
305 such as digging substructure, levelling new sub-structure, removing rail, etc.

306 The travel requirements for machines involved in projects varies from site to site and this is
307 difficult to estimate. Machines can travel from different maintenance yards, compounds and
308 locations and therefore the travel distances and impact was excluded from the study.

309

310 **3.3 Fuel Consumption Data Collection**

311 Most machines used in rail maintenance and renewal are diesel engine driven. Hence diesel
312 consumption is the main source of CO₂-e emission as far as the project activity is concerned. The
313 fuel consumption is primarily proportional to the rate of consumption and the running time of the
314 machines. The former is related to the type of machines and the latter to the project management
315 and maintenance process.

316 The data collection was collected at five track renewal sites in the state of New South Wales
317 in Australia.

- 318 • Project A consisted of a ballast cleaning project situated 35 km south of Sydney CBD. The
319 project utilised a ballast cleaning machine and no major delays were recorded.
- 320 • Project B consisted of a ballast clean with new track laid with a track laying machine. The
321 project was carried out 32 km south of Sydney CBD. Delays were experienced in obtaining
322 track possession but this did not affect the final construction programme.
- 323 • Project C consisted of a manual dig and lay situated 22 km north of Sydney CBD. The
324 excavation used a spoil train on the adjacent line with no delays recorded.
- 325 • Project D consisted of a manual dig and lay situated 25 km north of Sydney CBD. The
326 excavation used a spoil train on the adjacent line with no delays recorded.
- 327 • Project E consisted of a manual dig and lay methodology and was situated 16 km west of
328 Sydney CBD. The project had to cope with difficult access and site conditions. The project
329 was next to a train station platform which made it difficult to remove and replace the ballast.
330 The use of extra machines to remove and replace the materials was observed.

331 The data collection involved the identification of machines, their characteristic fuel
332 consumption rates and their running times in various projects. Fuel consumption CO₂-e emissions
333 were then calculated from the information collected.

334

3.4 Evaluation of GHG Emissions due to Fuel and Material Consumptions

A general equation for the evaluation of CO₂-e emissions relating to fossil fuel consumptions is given in DOE (2014) and is expressed as:

$$E_{ij} = Q_i C_i F_{ij} \quad (1)$$

where: E_{ij} is the amount of emission of gas species j relating to fuel type (kg).

Q_i is the quantity of fuel type i consumed by all the machines required on a project (kL).

C_i is the energy content factor of fuel type i (GJ/kL);

F_{ij} is the emission factor for gas j by fuel type i (kg/GJ).

In the current study, the primary focus is the carbon dioxide, methane, nitrous dioxide and the group of 4 synthetic gases (HFCs, SF₆, CF₄ and C₂F₆) emissions from diesel engines, hence i =diesel and j =1, 2, 3 corresponding to CO₂, CH₄, N₂O and the synthetic gas group. The corresponding parameter values are (DOE, 2014):

$$C = 38.6 \text{ GJ/kL};$$

$$F_1 = F_{\text{CO}_2} = 69.2 \text{ kg/GJ};$$

$$F_2 = F_{\text{CH}_4} = 0.2 \text{ kg/GJ};$$

$$F_3 = F_{\text{N}_2\text{O}+\text{synthetic gases}} = 0.5 \text{ kg/GJ};$$

The CO₂-e emissions of the maintenance work due to diesel fuel consumption is then evaluated from:

$$E = QC \sum_{j=1}^3 F_j \quad (2)$$

Note that the index of subscript 'diesel' is dropped for simplicity without causing confusion.

For comparison analysis, the CO₂-e emissions are evaluated on the basis of unit track length of maintenance. Denote the length of track by T . The CO₂-e emission per unit track length of maintenance, E_u is defined by:

$$E_u = \frac{E}{T} \quad (3)$$

356 The CO₂-e emission associated with construction material consumptions per unit track length, or the
 357 embodied CO₂-e emission per unit track length EM (kg/m), is evaluated according to:

$$EM = \sum_{k=1}^N EF_k QM_k \quad (4)$$

358 where: k is material index

359 N is the total number of material types used in track construction

360 EF_k is the embodied emissions factor for type k material (kg/kg)

361 QM_k is the quantity of material k required per meter of track construction (kg/m)

362

363 **3.5 Parametric Study**

364 The purpose of the parametric study was to compare the maintenance CO₂-e emissions and
 365 the total lifespan CO₂-e emissions for three different track systems. It is noted that lifespan in the
 366 context of the current study only include the time period of construction and operation phases of the
 367 lifecycle. A given track system may have a different lifespan and different track length to others. A
 368 meaningful comparison would be to examine the CO₂-e emissions in terms of CO₂-e emissions per
 369 unit track length and per year of lifespan, which is defined as the CO₂-e emission lifespan measure
 370 and denoted as E_l (kg/m.year) and is evaluated according to:

$$371 \left| E_l = \frac{E_m + E_{IC}}{L} \quad (5) \right.$$

372 where E_m is the total CO₂-e emission due to maintenance per unit track length (including material
 373 embodied and maintenance fuel consumption) over the lifespan (kg/m) ;

374 E_{IC} is the CO₂-e emissions per unit of track length for the initial construction (kg/m);

375 and

376 L is the given lifespan (year).

377 The maintenance CO₂-e emission per unit track length is a sum of the emissions due to
 378 materials and machinery, i.e., $(EM_r + E_u)$, where EM_r denotes the embodied CO₂-e emission in
 379 materials used in the maintenance projects. Over a given life span a railway track will undergo a

380 number of maintenance interventions which may consist of different activities. Introduce a
 381 maintenance type index n . For a known M types of maintenance activities, the maintenance CO₂-e
 382 emission per unit track length over a lifespan is evaluated from:

$$383 \left| E_m = \sum_{n=1}^M \left(\frac{L}{MF} (EM_r + E_u) \right)_n \right. \quad (6)$$

384 Where n is the maintenance activity index;

385 MF is the maintenance frequency.

386 The CO₂-e emissions per unit of track length for the initial construction is evaluated from

$$387 \left| E_{IC} = EM_{ic} + E_{CM} \right. \quad (7)$$

388 where E_{CM} is the CO₂-e emission per unit track length for construction machinery.

389 EM_{ic} is the CO₂-e emission per unit track length for materials used in initial constructions
 390 (kg/m).

391

392 **4 Results and Discussions**

393 **4.1 Maintenance management data**

394 The machines included in the data collection are listed in Table 1. Both projects A and B
 395 used a ballast under-cutter and track laying machine and Projects C, D and E used a manual dig and
 396 lay method which involved excavators and drotts (or bulldozer) removing and replacing the ballast
 397 and a bobcat and excavator replacing the sleepers. Front end loaders were used to place the steel rail
 398 into position.

399 Interviews with railway engineers and project managers were carried out to determine the
 400 characteristics of materials used in railway systems. It was found that materials can last well above
 401 the design life (examples of steel rail being used in practice for over 75 years), with this data
 402 considered in the maintenance frequencies in Section 3.5. The fuel consumption values were
 403 obtained from the machine operators after the completion of the projects. These values were
 404 substituted into Eq. (1) to obtain estimates of the CO₂-e emissions and the results are presented in

405 Table 3. The material requirements per metre for ballasted and two ballastless track types are shown
406 in Table 2.

407

408 **4.2 Machinery and CO₂-e Emission from Ballasted Track Renewal**

409 The machines and quantities used in projects A to E are shown in Table 1. The results show
410 that project E required the use of extra machines due to the difficult site conditions. The greatest
411 unpredictability in the construction programme is the time taken to remove and replace the
412 substructure. Specialised machines such as ballast under-cutters and track laying machines can
413 reduce the times, as can pre-fabricated materials components. The length of track to be renewed is
414 an important consideration in maintenance project management as the time available to complete
415 the works is limited.

416 The total CO₂-e emissions and emissions per unit length of track maintenance from the five
417 projects are listed in Table 3. Project E had the highest levels of total CO₂-e emissions and emission
418 per track length, due to the difficult site conditions and the need for extra machinery on site (see
419 Table 1).

420 Project E produced 53.63 kg CO₂-e emissions per metre of track. The machines used in
421 project A and B contributed 78 % and 86 % less CO₂-e emissions per metre of track when compared
422 to project E. The reduction in emissions are due to the use of the ballast under-cutter and track
423 laying machines which increased the efficiency in both projects A and B. Project C and D
424 contributed 53 % and 33 % less CO₂-e emissions respectively per metre of track when compared to
425 project E as the processed track lengths were relatively short in the former two projects and a
426 manual dig-and-lay construction methodology was used in lieu of ballast under cutters and track
427 laying machines.

428 The average CO₂-e emissions rates from projects A to E is shown in Table 3. The average
429 CO₂-e emissions per unit length of track were used in the parametric study to ensure the data
430 included an allowance for different construction methodologies and machinery.

431

432 **4.3 Material Impacts on Ballasted Track Plain-line Construction Projects**

433 In this analysis, plain-line renewal projects involved replacing and upgrading sections of
434 ballasted track bed. The materials requirements for each metre of track and the embodied emissions
435 factors are listed in Table 4. The embodied CO₂-e emissions from materials were estimated using
436 the embodied emissions factors obtained from the ICE (2011) database and Eq. (4). The material
437 quantities have been estimated based on the cross sections shown in Figure 2a for ballasted track.
438 Projects A to E used the same track bed cross section and therefore the embodied energy per metre
439 of track is the same.

440

441 **5 Discussion**

442 Table 5 shows the total CO₂-e emissions and the fraction contributions from fuel and
443 materials for Projects A to E. It is seen that materials contributed more CO₂-e emissions than fuel
444 consumption from machines in the renewal projects. The embodied emissions in steel and concrete
445 production are the source of greater CO₂-e emissions from the material components. The results
446 show that Project B (total length of 1375 m) has the lowest percentage of fuel CO₂-e emissions
447 when compared to the material emissions. The distribution share of emissions was 2 % and 98 %
448 respectively, due to the lowest fuel consumption per metre (see Table 3). The emissions from
449 Project E (281 m in length and highest fuel consumption rate per metre, Table 3) shows that
450 machines have a 10 % contribution of CO₂-e emissions and materials contribute 90 % of the total
451 CO₂-e emissions.

452 No maintenance project is a carbon copy of another. Many factors, including the project
453 scale, the maintenance method and the detailed process, varied from project to project. These
454 variations were reflected in the fuel consumption with the random attribute as is seen in both E_u
455 presented in Table 3 and in the fraction contribution to the total CO₂-e emission presented in Table
456 5. Notwithstanding, the range of variation from 2 % to 10 % fuel contribution fraction of CO₂-e

457 emission in the maintenance of the ballasted track is comparable with the result (18 %) obtained by
458 Chang and Kendall (2011) for the initial construction phase. The lower value of the current study
459 may be attributable to the exclusion of other factors such as travel and material transportation.

460 Kiani et al. (2008) found that the CO₂-e emissions from ballastless track over the lifecycle
461 were not associated with increased CO₂-e emissions when compared to ballasted track bed. Kiani et
462 al. (2008) concluded that ballasted track construction CO₂-e emissions were a little more than half
463 of the ballastless track construction CO₂-e emissions, however, maintenance activities including
464 ballast cleaning, ballast resurfacing and renewals increased the lifecycle CO₂-e emissions to similar
465 levels.

466 The data collected was a small sample due to the limitations of weekend shutdown work, the
467 difficulty in accessing sites with large volumes of machinery movements and the costs associated
468 with the data collection. A degree of uncertainty is associated with any construction project and to
469 solely implement the results of this study in a life-cycle emissions assessment would be crude and
470 imprecise. Nonetheless, the sample data could be used to conduct statistical analysis to provide
471 descriptions of the characteristics.

472 Monte Carlo simulation would be an appropriate method to carry out the analysis (Coelli,
473 1995). The difficulty, however, in relying on values from a small sample size is the discrepancies in
474 the fuel consumption from the data collection. It may be plausible to assume that the data collection
475 projects in this study covered a reasonable range of case scenarios from the relative simple projects
476 A and B to the more intricate project E. A statistical analysis would then be applied to ensure a
477 degree of certainty is established in the data results and the data could be used with confidence in
478 the future studies.

479

480 **6 Parametric Study**

481 Routine maintenance activities such as ballast tamping and rail head grinding have the
482 capacity to increase component life, with Milford and Allwood (2011) concluding that by extending

483 the life of railway tracks through maintenance, CO₂-e emissions per year of their lifespan may be
484 reduced. A parametric study was carried out to analyse the impact of the maintenance and renewal
485 of railway track on CO₂-e emissions over time. The study compared the construction and
486 maintenance portion of the lifecycle emissions from ballasted track, Rheda 2000 cast-in sleeper
487 concrete slab track and Balfour Beatty embedded slab track (BBEST).

488 Table 6 shows the frequencies of maintenance activities used in the parametric study. The
489 frequencies are used to ascertain the maintenance commitments for the lifecycle of the
490 infrastructure. For ballasted track, the major track renewal interval is assumed to be 40 years and
491 two renewals are conducted. As a result, the ballasted track lifespan is 120 years. The replacement
492 of rails in the ballasted track was assumed to be with the renewal projects (at a 40-year interval), as
493 in practice. Ballast cleaning and replacement was set at 20 years after construction and re-
494 construction. Ballast resurfacing is considered on a 4 year interval.

495 For the ballastless tracks the lifespan is set at 100 years. The main maintenance activities on
496 ballastless track are rail grinding and rail replacement. Milford and Allwood (2010) explained that
497 60 kg/m steel rail had the potential to last 13 - 38 years, depending on axle loads, wagon suspension
498 and train frequencies. The parametric study considered a 25 year interval for replacing steel rail in
499 the ballastless track types. A conservative rail replacement interval has been used due to the higher
500 speeds in ballastless track types and the more frequent requirement of rail head grinding.

501 The maintenance frequencies are used to calculate the total emissions with the E_m rate in
502 Table 6. The CO₂-e emissions per unit length of track maintenance obtained from the data
503 collection as shown in Table 3 are used to determine the total emissions over the lifespan of the
504 ballasted track.

505 Figure 3 illustrates the CO₂-e emissions from maintenance per unit of track of the ballasted
506 track, Rheda 2000 track and BBEST over a lifespan. The ballasted track has a lifespan of 120 years,
507 whilst the ballastless tracks are assumed to be 100 years. Results were generated at the time of 30
508 years, 60 years and end of the lifespan. It can be seen at 30 years, the construction and maintenance

509 of ballasted track was 54 % and 55 % less emissions than the Rheda 2000 and BBEST systems
510 respectively. This is due to the greater emissions from the construction of the ballastless track types.

511 At the 60 year interval, the ballasted track system emits 29 % and 31 % less CO₂-e
512 emissions compared to Rheda 2000 and BBEST respectively. In this time period, the ballasted track
513 bed required a full track renewal and two ballast cleaning interventions in the time period compared
514 to only a rail renewal in the Rheda 2000 and BBEST track.

515 At the end of lifespan the ballasted track emitted 13 % and 15 % less CO₂-e emissions than
516 the Rheda 2000 and BBEST systems respectively as indicated in Figure 3. The Rheda 2000 emitted
517 2 % less CO₂-e emissions than the BBEST system. The greater CO₂-e emissions from the BBEST
518 over the Rheda 2000 system is attributed to the larger material cross section of the two ballastless
519 construction types.

520 As the lifespan prolongs the maintenance emission (E_m) of ballasted track increases faster
521 than that of the other two systems. Hence, the total emissions (E_m+E_{IC}) of the ballasted track
522 increased faster after the initial construction to the end of life, as expected due to the increased
523 maintenance requirement. Overall, the comparison of the three track types show that the ballasted
524 track maintenance CO₂-e emissions were the least when compared to Rheda 2000 and BBEST over
525 the whole lifespan. The ballast material requires more frequent and complicated maintenance to
526 ensure effective and safe train operations. On the other hand, the ballastless track types emit greater
527 emissions during construction and this is shown in the increased overall emissions. It is also noted
528 that the disposal of the materials are excluded from the study due to the limitations and complexity
529 of including these in the study.

530 Although Figure 3 reveals the differences in CO₂-e emissions between the three track types,
531 it actually gives a biased comparison since the three tracks were evaluated at different lifespans. A
532 meaningful comparison should be made on the basis of CO₂-e emission lifespan measure, E_l (or
533 CO₂-e emission per unit track length per year of lifespan), as presented in Figure 4. It is revealed
534 that over the 30 years, 60 years and end of lifespan, the ballasted track emits the least greenhouse

535 gas per unit length of track and per year of lifespan. Table 7 shows the percentage ratio of various
536 emission lifespan measures of various tracks to that of ballasted at the 30, 60 and end of life
537 intervals. It is seen that for the 30 and 60 year time intervals Rheda 2000 and BBEST emit 14 %
538 and 17 % more CO₂-e emission respectively than ballasted track. At the end of life, these
539 differences are increased to 37 % and 41 % respectively.

540

541 **7 Conclusion**

542 This study evaluated the CO₂-e emissions from ballasted track bed maintenance and renewal
543 activities. The evaluation was based on a field survey which covered a range of site scenarios. The
544 results were analysed and compared with that of two ballastless track bed systems.

545 The data collected from the ballasted track site surveys showed that the machinery CO₂-e
546 emissions varied from 2 % to 10 % of the total CO₂-e emissions of the projects. The material
547 component of renewal project contributes the most CO₂-e emissions due to embodied emissions in
548 material production. This is a similar result to that of the study carried out by Chang and Kendall
549 (2011) for the initial construction phase of the lifecycle.

550 In ballasted track, steel rail and concrete sleepers contributed 92 % of the total materials
551 CO₂-e emissions, therefore the lifecycle CO₂-e emissions of steel rail and concrete sleepers could be
552 reduced if an increase in service life was achieved.

553 Albeit the initial objective was to reduce the uncertainties associated with the assumptions in
554 previously used estimates, the results of the current study have revealed that the greenhouse gas
555 emission per unit track length of maintenance due to fuel consumption is a random variable. It
556 varies from project to project for the same track system. Any attempt to use an assumed average for
557 the analysis of a general project would be a crude approach and the result would contain a degree of
558 uncertainty.

559 Despite the total emission of the three track systems increase with lifespan, their lifespan
560 measures diminish with the prolonging of lifespan. However, the differences in the three track

561 systems increase with lifespan in terms of CO₂-e emission per unit track length per year of lifespan
562 increases. The ballasted track appears to be the best performer to have the lowest lifespan measure.
563 In comparison, the BBEST has the highest emission per lifespan measure.

564 A number of emission contributing factors, such as fuel consumption in travel to
565 maintenance sites and the demolition, disposal or recycling of materials from the renewal projects,
566 were not included in the current study. These factors can be included in future studies.
567 Recommendations for future work also include a survey study on the construction of ballastless
568 track systems to obtain more reliable results for comparison with ballasted track bed construction. It
569 would be desirable to collect and analyse data from more maintenance projects to obtain more
570 reasonable estimates of the random behaviour of the key indicators such as CO₂-e emission per unit
571 track length of maintenance of any type. Furthermore, statistical or Monte Carlo simulation studies
572 can be conducted to understand the uncertainty associated with the parametric study.

573 The input parameters of the parametric study were based on the existing and newly obtained
574 information. It can be certain that the technological advancement in the future will result in changes
575 in materials, tools and practice for the construction and maintenance of railway systems. Further
576 development of the model would be necessary to take technological advancement into account for
577 estimating greenhouse emissions.

578

579 **Acknowledgements**

580 The authors would like to thank the University of Western Sydney for funding of this work.
581 Special thanks to all assistance from Railcorp, Anric Rail, Dave Ormsby Haulage Pty Ltd, C and L
582 Sultana Earthmoving and G & S cranes for assistance in fuel consumptions, Mr. Wai Chung Mok
583 from UWS and all work group leaders and engineers for their assistance in worksite data collection.
584 Valuable comments from Professors Joseph Sussman and Hubert Einstein (MIT CEE) are
585 gratefully acknowledged. The last author wishes to thank Australian Government for his Endeavour

586 Executive Fellowships at Massachusetts Institute of Technology, at Harvard University, and at
587 Chalmers University of Technology.

588

589 **References**

590 Burrow, M. P. N., Bowness, D., Ghataora, G. S., 2007. A comparison of railway track foundation
591 design methods. Proceeding of the institution of mechanical engineers. 221 (F1). Pp. 1 – 12.

592 Chang, B., and Kendall, A., 2011. Life cycle greenhouse gas assessment of infrastructure
593 construction for California's high-speed rail system. Transportation Research Part D. 16. Pp.
594 429 - 434.

595 Chester, M., and Horvath, A., 2009. Environmental assessment of passenger transportation should
596 include infrastructure and supply chains. Environmental Research Letters (4). IOP Publishing.
597 Pp. 1-8. doi:10.1088/1748-9326/4/2/024008.

598 Coelli, T., 1995. Estimators and hypothesis tests for a stochastic frontier function: A Monte Carlo
599 analysis. The Journal of productivity analysis. (6). Pp. 247 – 268.

600 Correa, N., Oyarzabel, O., Vadillo, E. G., Santamaria, J., Gomez, J., 2011. Rail corrugation
601 developments in high speed lines. International Journal of Wear. 271 (1). Pp. 2438 – 2447.

602 DOE, 2014. National Greenhouse Accounts Factors. Department of the Environment,
603 Commonwealth of Australia. Canberra. www.environment.gov.au

604 Esveld, C., 2003. Recent developments in slab track. European railway review.

605 Girsch, G., Frank, N., Pointner, P., and Stock, R., 2008. Life cycle cost considerations on high
606 strength rail steels. International Union of Railways.
607 http://www.uic.org/cdrom/2008/11_wcrr2008/pdf/I.2.2.1.1.pdf

608 ICE, 2011. Inventory of carbon and energy. University of Bath. Version 2.0.

609 Indraratna, B., Rujikiatkamjorn, C., Vinod, J.S., 2009. A review of ballast characteristics,
610 geosynthetics, confining pressures and native vegetation in rail track stabilisation. Transport
611 engineering in Australia, 12(1), pp. 25-36.

612 Kaewunruen, S. and Remennikov, A.M., 2008. Effect of a large asymmetrical wheel burden on
613 flexural response and failure of railway concrete sleepers in track systems. *Journal of*
614 *Engineering Failure Analysis*. (15). Pp. 1065 – 1075.

615 Kaewunruen, S. and Remennikov, A.M., 2010. Dynamic crack propagations in prestressed concrete
616 sleepers in railway track systems subjected to severe impact loads. *Journal of Structural*
617 *Engineering*. (136). Pp. 749 – 754.

618 Kaewunruen, S., Remennikov, A.M. and Murray, M.H., 2011a. Greener & Leaner: Unleashing the
619 capacity of railroad concrete ties." *ASCE Journal Transportation Engineering*, 137(4): 241-247

620 Kaewunruen, S., Remennikov, A.M. and Murray, M.H., 2011b. Limit states design of concrete
621 sleepers. *Procs. ICE Transport*. 165(TR2), 81-85

622 Kaewunruen, S., Remennikov, A.M. and Murray, M.H., 2014. Introducing limit states design
623 concept to concrete sleepers: an Australian experience. *Frontiers in Materials*, doi:
624 10.3389/fmats.2014.00008.

625 Kaewunruen, S., Sussman, J.M. and Einstein, H.H., 2015, Strategic framework to achieve carbon-
626 efficient construction and maintenance of railway infrastructure systems. *Front. Environ. Sci.*
627 3:6. doi: 10.3389/fenvs.2015.00006.

628 Kiani, M., Parry, T., Ceney, H., 2008. Environmental life-cycle assessment of railway track beds.
629 *Proceedings of the Institution of Civil Engineers. Engineering sustainability* 161. Issue ES2.

630 Lee, C.K, Lee, J.Y, Kim, Y.K, 2008. Comparison of environmental loads with rail track systems
631 using simplified life cycle assessment (LCA). *WIT transactions on the Built Environment* 101,
632 367 – 372.

633 Lewis, R. and Olofsson, U., 2004. Mapping rail wear fatigues and transitions. *Wear - Elsevier*. 257.
634 Pp. 721 -729.

635 Manalo, A., Aravinthan, T., Karunasena, W., Ticoalu, A., 2010. A review of alternative materials
636 for replacing timber sleepers. *Journal of composite structures*. 92, pp. 603 – 611.

637 Michas, G., 2012. Slab track systems for high speed railways. Royal institute of technology,
638 Stockholm, Sweden. Master degree project.

639 Milford, R. and Allwood, J., 2010. Assessing the CO₂ impact of current and future track in the UK.
640 Transport Research Part D 15, pp 61 - 72.

641 Podofillini, L., Zio, E., Vatn, J., 2006. Risk-informed optimisation of railway tracks inspection and
642 maintenance procedures. Reliability Engineering and Safety Systems. **91**. Pp. 20 – 35.

643 Rao, H. S., 2010. Reducing carbon emissions from transport projects. Independent evaluation.
644 Asian development bank.

645 Railcorp, 2012. Track fundamentals TMC 202. Engineering manual.

646 Remennikov, A.M. and Kaewunruen, S., 2008. A review of loading conditions for railway track
647 structures due to train and track vertical interaction, *Structural Control and Health Monitoring*.
648 **15**(2), 207-234.

649 Remennikov, A.M. and Kaewunruen, S., 2014. Experimental load rating of aged railway concrete
650 sleepers, *Engineering Structures*. in press.

651 Rheda, 2000. Ballastless track system. Rail.One. [http://www.railone.com/fileadmin/daten/05-](http://www.railone.com/fileadmin/daten/05-presse-medien/downloads/broschueren/en/Rheda2000_EN_2011_ebook.pdf)
652 [presse-medien/downloads/broschueren/en/Rheda2000_EN_2011_ebook.pdf](http://www.railone.com/fileadmin/daten/05-presse-medien/downloads/broschueren/en/Rheda2000_EN_2011_ebook.pdf)

653 Schwarz, H., 2009. Carbon footprint of high-speed railway infrastructure (pre-study). International
654 union of railways.

655 Ueda, H., Miyauchi, T., Tsujimura, T., 2003. Application of lifecycle assessment to Shinkansen
656 vehicles and cross ties in Japan. Proceedings of the institution of mechanical engineers.
657 Rail and Rapid Transit. 217, pp. 271 – 278.

658 Von Rozycki, C., Koeser, H., Schwarz, H., 2003. Ecology profile of the German high-speed rail
659 passenger transport system, ICE. International Journal of life-cycle assessment. 8 (2). Pp. 83
660 – 91.

661
662
663
664

Table 1. Machines and their numbers used in the five surveyed projects.

Machine used	Project A	Project B	Project C	Project D	Project E
Ballast under-cutter	1	1			
Bobcat	1	2	1	1	1
Excavator (6 tonne)	2	2	1	1	2
Excavator (14-16 tonne)	1	4	3	3	4
Drott		1	1	1	3
Dump truck (5 tonne)	2	2	1		2
Dump truck (14 tonne)		2			7
Front end loader	2	2	3	2	3
Grader	1	1			
Regulator	1	1	1	1	1
Smooth drum roller	1	1	1	1	1
Stabiliser	1	1	1	1	
Tamper	1	1	1	1	1
Tipper bogie		1			8
Track jack	1	1	1		
Track laying machine	1	1			
Total number of machines used	16	24	15	12	33

666

667

668

669

Table 2. Material requirements for various track beds.

Type of Track System	Material	Weight per Metre of railway track (kg/m)	Source
Ballasted – Heavy duty sleepers (Figure 2a).	Road base	1272	Current study
	Ballast	2067	Current study
	Concrete sleepers	561	Current study
	Steel rails	120	RailCorp (2012)
	Resilient plastic pads	1.74	Current study
	Insulators	0.24	Current study
	Steel e-clips	5.44	Current study
Rheda 2000 slab track system: Cast in sleeper with concrete foundation and exposed rail (Figure 2b).	Reinforcing bars	21.54	Kiani et al. (2008)
	Aggregate	3346	Kiani et al. (2008)
	Cement	348	Kiani et al. (2008)
	Steel rail	120	Kiani et al. (2008)
	Rail pads	1.02	Kiani et al. (2008)
	Fastenings	30.8	Kiani et al. (2008)
BBEST System: Concrete sub-base and foundation with embedded rail (Figure 2c).	Mass of reinforcing steel	116	Kiani et al. (2008)
	Aggregate	2140	Kiani et al. (2008)
	Cement	366	Kiani et al. (2008)
	Shell	5	Kiani et al. (2008)
	Seal	0.4	Kiani et al. (2008)
	Grout	55	Kiani et al. (2008)
	Resilient pads	1.7	Kiani et al. (2008)
	Steel Rails	148	Kiani et al. (2008)

670

671

672

673

Table 3. Recorded project data and results of CO₂-e emission from machinery usage.

Project	<i>T</i> (m)	<i>Q</i> (L)	<i>E</i> (kg)	<i>E_u</i> (kg/m)
A	551	2460	6637	12.05
B	1375	3701	9986	7.26
C	170	1594	4301	25.30
D	135	1846	4981	36.90
E	281	5585	15069	53.63
Average	503	3038	8195	27.03

674

675

676

677

678

Table 4. Embodied emissions factors (ICE Database, 2011) and the evaluated embodied carbon emission per unit length of track.

Materials	<i>EF</i> (kg/kg)	<i>QM</i> (kg/m)	<i>EM</i> (kg/m)
Roadbase	0.0051	1272	6.49
Ballast	0.005	2067	10.34
Concrete Sleepers	0.277	561	155.40
Steel Rail	2.78	120	333.60
Plastic Pads	3.0	1.02	3.06
Insulators	3.0	0.68	2.04
Resilient e-clips	2.78	5.44	15.13
Total			526.06

679

680

681

682

Table 5. Total and fraction of CO₂-e emissions from materials and machinery.

Project	Total CO ₂ -e emissions (kg)	Fraction of machinery contribution	Fraction of material contribution
A	290,171	3 %	97 %
B	724,111	2 %	98 %
C	89,527	6 %	94 %
D	71,095	6 %	94 %
E	147,982	10 %	90 %

683

684

685

686

Table 6. Maintenance intervals (Milford and Allwood, 2011 and Kiani et. al., 2008) used in parametric study and CO₂-e emissions from maintenance as per data collection.

Maintenance activity	Track type and maintenance intervals (year)			<i>E_m</i> rate for track maintenance (kg/m)
	Ballast Track	Rheda 2000	BBEST	
Track renewals	40	N/A	N/A	554
Rail head grinding	2	1	1	0.53
Rail Replacement	with renewal	25	25	336
Ballast resurfacing	4	N/A	N/A	1.17
Ballast cleaning / replacement	20 - alternating with renewal	N/A	N/A	11.83

687

688
689

Table 7. Comparison of CO₂-e emission lifespan measure relative to that of ballasted track at different period.

Track type	30 year (%)	60 year (%)	End of lifespan (%)
Ballasted track	100	100	100
Rheda 2000	114	114	137
BBEST	117	117	141

690
691
692
693
694
695
696
697
698
699
700
701
702
703
704
705
706
707
708

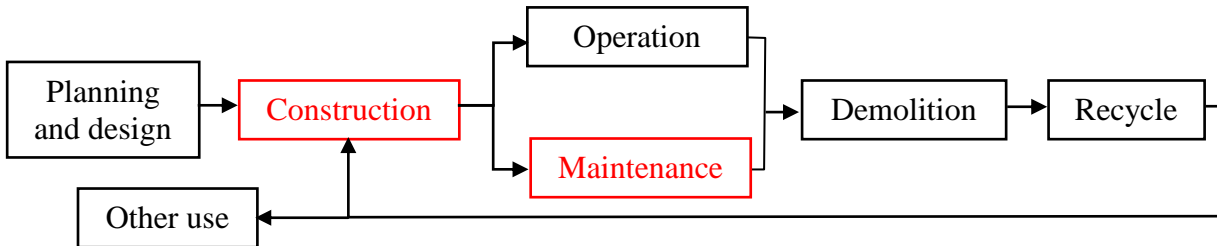

a. Typical lifecycle of a railway system and the phases included in the current study (in red).

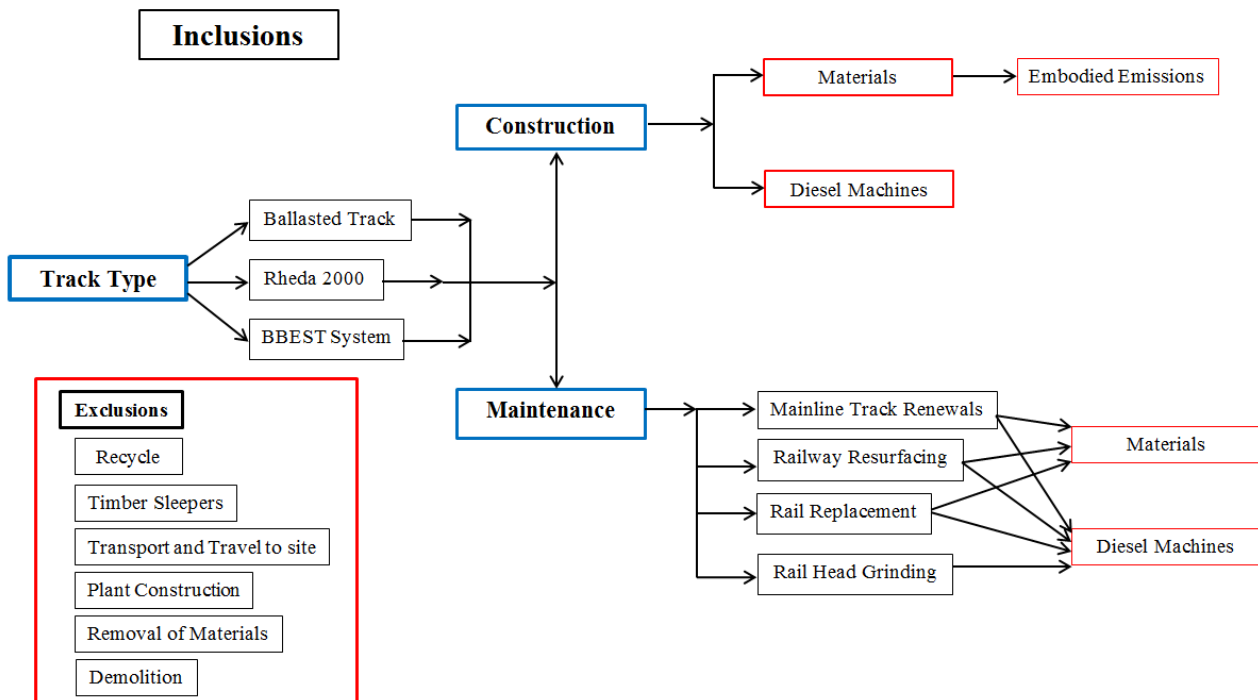

b. Scope of the maintenance CO₂-emission estimate in the current study.

709
710
711
712
713
714
715
716
717

Figure 1. Lifecycle of railway systems.

718

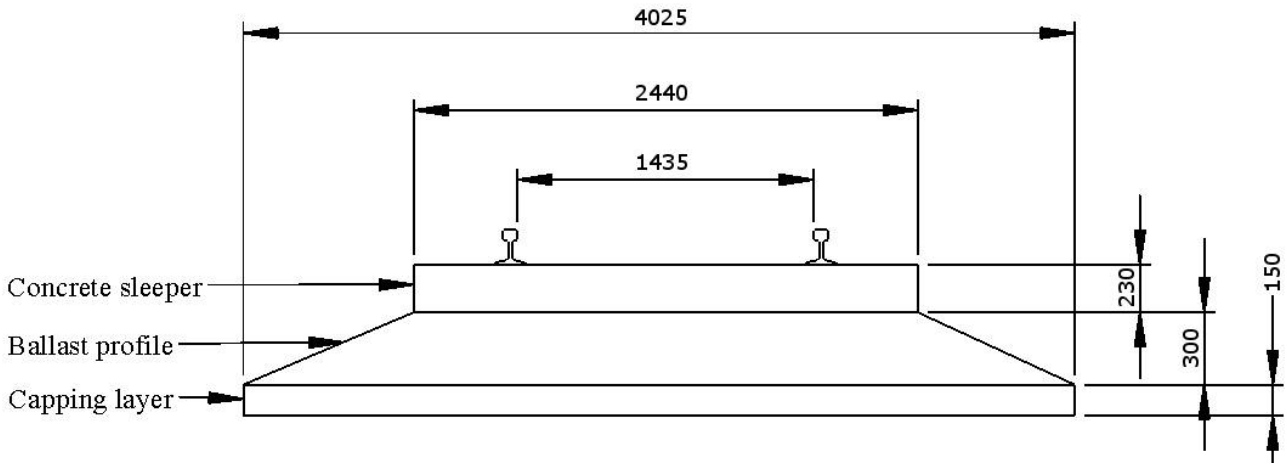

a. Ballasted track bed construction cross section (Courtesy Railcorp, 2012)

719
720
721
722
723
724

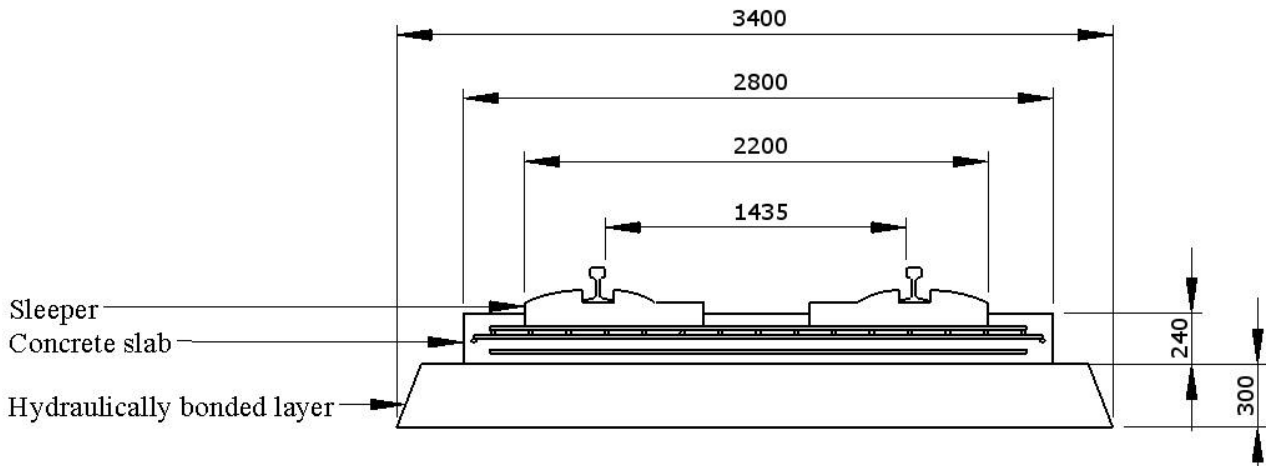

b. Rheda slab track system construction cross section (courtesy Rheda, 2000).

725
726
727
728
729

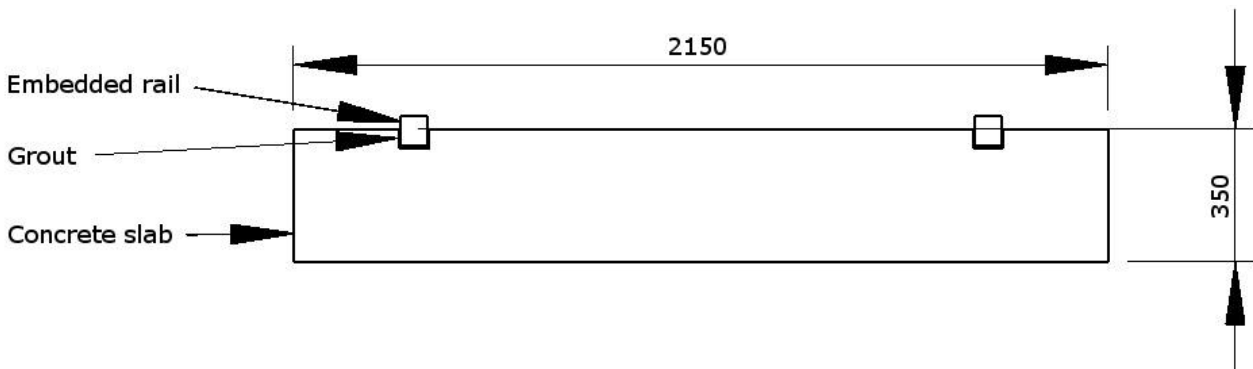

c. Embedded slab track construction cross section.

730
731
732
733
734
735

Figure 2. Illustrations of three types of railway track bed constructions.

736
737

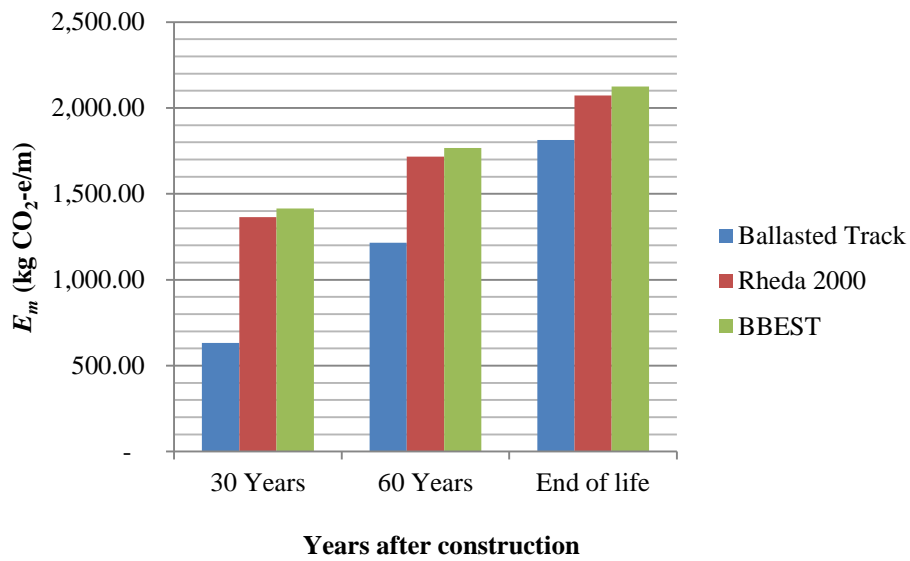

738
739
740
741
742
743
744

Figure 3. Total CO₂-e emissions from maintenance activities per unit length of three track systems over different lifespans.

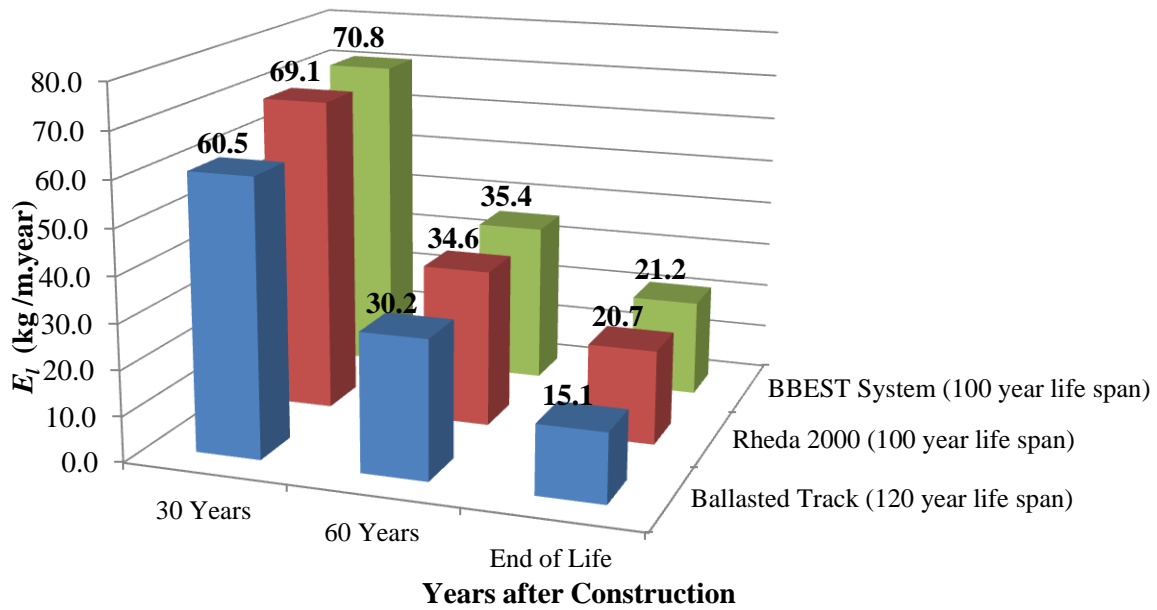

745
746

Figure 4. Results of E_l for the three track types.