

Stationary fuel cell power supply for railway electrification systems

Roth, Steffen; Tricoli, Pietro

DOI:

[10.1109/CPE-POWERENG58103.2023.10227490](https://doi.org/10.1109/CPE-POWERENG58103.2023.10227490)

License:

Other (please specify with Rights Statement)

Document Version

Peer reviewed version

Citation for published version (Harvard):

Roth, S & Tricoli, P 2023, Stationary fuel cell power supply for railway electrification systems. in *2023 IEEE 17th International Conference on Compatibility, Power Electronics, and Power Engineering (CPE-POWERENG)*, 10227490, Compatibility in power electronics, Institute of Electrical and Electronics Engineers (IEEE), 17th International Conference on Compatibility, Power Electronics and Power Engineering, Tallinn, Estonia, 14/06/23. <https://doi.org/10.1109/CPE-POWERENG58103.2023.10227490>

[Link to publication on Research at Birmingham portal](#)

Publisher Rights Statement:

S. Roth and P. Tricoli, "Stationary fuel cell power supply for railway electrification systems," 2023 IEEE 17th International Conference on Compatibility, Power Electronics and Power Engineering (CPE-POWERENG), Tallinn, Estonia, 2023, pp. 1-6, doi: 10.1109/CPE-POWERENG58103.2023.10227490.

© 2023 IEEE. Personal use of this material is permitted. Permission from IEEE must be obtained for all other uses, in any current or future media, including reprinting/republishing this material for advertising or promotional purposes, creating new collective works, for resale or redistribution to servers or lists, or reuse of any copyrighted component of this work in other works.

General rights

Unless a licence is specified above, all rights (including copyright and moral rights) in this document are retained by the authors and/or the copyright holders. The express permission of the copyright holder must be obtained for any use of this material other than for purposes permitted by law.

- Users may freely distribute the URL that is used to identify this publication.
- Users may download and/or print one copy of the publication from the University of Birmingham research portal for the purpose of private study or non-commercial research.
- User may use extracts from the document in line with the concept of 'fair dealing' under the Copyright, Designs and Patents Act 1988 (?)
- Users may not further distribute the material nor use it for the purposes of commercial gain.

Where a licence is displayed above, please note the terms and conditions of the licence govern your use of this document.

When citing, please reference the published version.

Take down policy

While the University of Birmingham exercises care and attention in making items available there are rare occasions when an item has been uploaded in error or has been deemed to be commercially or otherwise sensitive.

If you believe that this is the case for this document, please contact UBIRA@lists.bham.ac.uk providing details and we will remove access to the work immediately and investigate.

Stationary fuel cell power supply for railway electrification systems

Steffen Roth
Dept. Electronic, Electrical, and Systems Eng.
University of Birmingham
Birmingham, United Kingdom
srr801@student.bham.ac.uk

Pietro Tricoli, *Senior Member, IEEE*
Dept. Electronic, Electrical and Systems Eng.
University of Birmingham
Birmingham, United Kingdom
p.tricoli@bham.ac.uk

Abstract—The reduction of CO₂ emissions in the transport sector is one of the main objectives of the railway industry. Reliable railway operations require a dynamic and reliable energy supply and a direct access to renewable energy sources. Stationary fuel cell systems allow a decentralised power supply to reduce the grid dependency and allow the direct usage of green hydrogen, which can be produced in the vicinity of the railway line. The good transportability of hydrogen as a long-term energy storage medium in combination with the low maintenance and infrastructure cost of stationary fuel cells make hydrogen a viable solution for the electrification of some railway lines. Because of the good efficiency and the possibility of usage in co-generation systems, solid-oxide fuel cells systems would support the targeted environmental goals. By utilising and extending the existing infrastructure of catenary electrified tracks and operating with a simplified mobile application, a low maintenance and efficient stationary energy generation technology is proposed in this paper, to allow a cost- and energy-efficient decarbonisation of the railway industry.

Keywords— Solid-oxide fuel cells, railways, decentralised power supply, grid-connected systems, renewable energies, stationary fuel cells.

I. INTRODUCTION

The need for decarbonisation is affecting all transport sectors, including railways that are already one of the cleanest transport means [1]. While electric trains are widely used for passengers and goods on busy lines, the majority of lines in less densely populated areas are not electrified and diesel trains are still in use. The transition to electrification of the existing diesel fleets will inevitably add significant strain to the power grid, especially at peak times. Therefore, true decarbonisation can be achieved only with an adequate increase of electrical power generated by renewable energy sources. However, the variability of power generation of these sources requires the development of technological solutions, to ensure a matching generation and demand. Energy storage is an effective technology to reduce the effects of this fluctuation [2]. Due to the distributed nature of renewable power sources, it is likely that energy storage will also be decentralised. However, a large quantity of energy storage would be needed for the existing and future electrical loads of the grid, and with large capacities for loads like railways. Looking at the existing energy densities of energy storage [3], it is clear that hydrogen will play an essential role to achieve decarbonisation, due to the high energy density, the simplicity of storage and transport. Green hydrogen, i.e. obtained from renewable sources, can be generated with large

electrolysers to increase efficiency. Then, it can be distributed to local fuel cells (FCs) to generate power when there is a mismatch between the power requirement and the power generated by renewable sources. Hydrogen can be easily transported by pipelines and trucks and stored in almost any location, and the tanks can be designed according to the individual load demand.

To date, hydrogen for railway transport has been only proposed for independently powered trains [4], some of them already operating in Germany [5], and often in combination with batteries [6]. The main benefit is the avoidance of the construction of overhead electrical lines and traction substations, which often do not have a viable business case for lines with low number of passengers and/or goods. However, hydrogen trains are less efficient and heavier than electric trains supplied by the overhead line [7]. Due to the additional weight of a mobile FC or battery system, the energy consumption is 5-15% higher than electric trains [8]. When a FC is equipped with an additional battery pack, the recuperation of braking energy is possible, with a positive effect on the overall consumption. For such an operation the FC provides the baseload power while the battery provides the peak power. The holistic energy consumption evaluation of the hybrid configuration results in an energy demand 3-11% higher than electric trains with the same system performance [9]. Even looking only at the electricity generation, the efficiency of mobile FCs, largely based on a proton-exchange membrane (PEM) technologies, is lower than stationary systems, which can be based on solid-oxide fuel cells (SOFCs) technologies [10].

SOFCs can use either hydrogen, carbon monoxide or methane as a fuel, thereby increasing flexibility for the supply of primary energy, and have a high tolerance to impurities and internal reforming capabilities. Due to the high temperature, various fuels can be used based, and efficiency of 45-50% is achievable. This can be further increased by a combined heat and power (CHP) system, for example heating the train stations nearby or other railway facilities.

Therefore, an electric railway powered by stationary FCs, supplied by their own hydrogen tanks located in the vicinity of the tracks, can be potentially a solution more economical than the connection to high-voltage transmission network typical of AC railways, or a mobile FC application. Additionally, the inverters of the FCs can be used to reduce the imbalance caused by the railway. As an example, Fig. 1 shows a decentralised power supply of a track segment of the traction power network from a FC, where hydrogen is generated by local renewable energy sources.

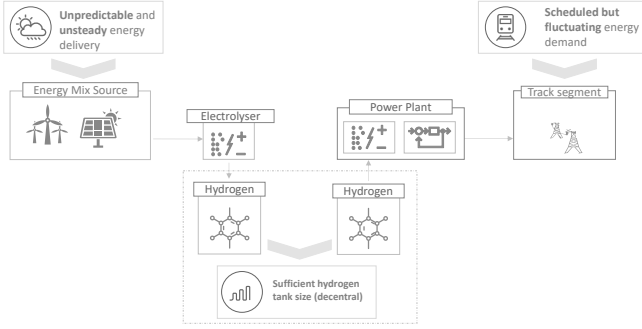

Figure 1: End-to-End energy model

When stationary FCs are used to supply variable loads like railways, the dynamic response to sudden variations of the power demand can cause some concerns. To address these concerns, a model of SOFC based on its physical response was developed in [11] and [12], showing that the system can react to load changes in satisfactory way [13]. Also, integrated SOFC plant dynamic models [14] have been used to simulate the basic SOFC power section to assess performance during normal operations. A grid connected SOFC has been experimentally tested in [15] with a 100-kW unit that can operate either connected to the grid or independently with an acceptable dynamic response based on different use cases with ramp changes and step changes. Since 2022, the companies Plug Power and Vaillant have tested centrally controlled and grid connected SOFC plants in Germany, Netherlands and Australia to meet the peak energy demand of households confirming again good dynamic response. Additional use cases and research has taken place over the last years which can be found in [16].

The aim of this paper is to verify if stationary FCs are effective to directly supply electric railways, reducing the reliance on the power grid. In a scenario of high penetration of renewable energy sources, they would be a valid option for the decarbonisation of railways as hydrogen would be generated without carbon emissions. The leading question is the assessment of the power demand when there is lack of synchronisation between the generation and the use from the railway and the need of specific control techniques of the FC to meet the dynamic power demand from the railway by reducing the dependency on the grid. To verify this hypothesis, a mathematical model and a numerical simulator of a railway line fed by FCs and renewable sources has been developed taking into account the instantaneous power demand of the trains. The SOFC has been controlled to cope with the fast variation of the train power demand as well as the fluctuation of renewable power sources. Numerical results are provided for a case study of a railway line in the UK.

II. SYSTEM MODELLING

A. Decentralised power supply

AC railways are usually split into isolated track segments, each fed from a different phase of the main grid via single-phase traction power substations (TPSS). In the proposed configuration, a SOFC system is located in each TPS, with a 3-phase inverter and transformer, as shown in Fig. 2, that directly feeds the bus bar of the traction transformer [9]. The SOFC voltage output needs to be boosted by a DC-DC

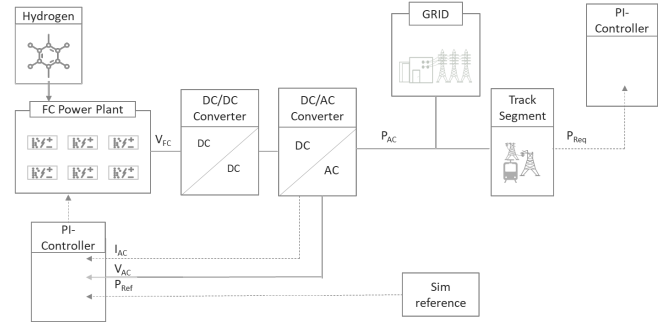

Figure 2: Connection of SOFC to track segments

converter before the transformation into AC. This DC-DC converter is controlled with a typical dual loop, with an inner loop to control the SOFC current and an outer voltage loop to regulate the dc-link.

The inverter is controlled to instantaneously respond to the power demand variation of the railway, so the grid intervention is minimised. Therefore, the power grid is monitored and compared with a zero reference to generate the current reference signal for the inverter [17], assuming that the FC tank is designed to capture the maximum amount of hydrogen generated by local renewable sources via electrolyzers and/or a supply chain based on trucks or pipelines. An alternative concept based on stationary batteries, which could be swapped at regular interval, would also be theoretically possible but is not practicable as their size would lead to enormous efforts at each swapping. The refilling of the hydrogen tanks is much more practical and therefore it has been chosen. The control of the inverter is based on the traditional synchronous reference frame [18] and the quadrature reference current can be chosen equal to 0 for the minimisation of the reactive power, or can be obtained from an imbalance controller that tries to keep at 0 the negative sequence of the grid current [19].

B. Train simulator

The train simulator of the University of Birmingham enables the simulation of a realistic track segment with a realistic train load and it has been used to calculate the instantaneous power demand of the railway that represents the power reference for the SOFC.

C. SOFC Model

A FC system has been modelled with stacks of SOFCs to generate a total of 3 MW power output. The model of each SOFC uses the following assumptions:

- FC gases are ideal;
- only one value of the pressure is defined in the interior of the electrodes;
- FC temperature is constant.

With these hypotheses, the ideal output voltage of a single FC is given by the Nernst equation [20], [21]:

$$E_{cell} = E_0 + \frac{RT}{nF} \ln \frac{P_{H_2} P_{O_2}^{-\frac{1}{2}}}{P_{H_2O}}, \quad (1)$$

where R is the universal constant of gases, F is the Faraday constant, E_0 is the ideal FC voltage, and the partial pressure of the gases can be calculated by the following equations:

$$PH_2 = \frac{1/K_{H_2}}{1+\tau_{H_2}s} \left(\frac{1}{1+\tau_{f_s}} qf^{in} - 2K_r I \right) \quad (2)$$

$$PO_2 = \frac{1/K_{O_2}}{1+\tau_{O_2}s} \left(\frac{1}{r_{H-O}} \frac{1}{1+\tau_{f_s}} qf^{in} - K_r I \right) \quad (3)$$

where the parameters can be found in Tab. I.

In the chemical process of SOFCs, the fuel utilisation is equal to the ratio between the flow rate of reacting fuel (qH_2^r) and the flow rate of fuel (qH_2^{in}):

$$U_{cf} = \frac{qH_2^r}{qH_2^{in}}, \quad (4)$$

where:

$$qH_2^{in} = \frac{2K_r I}{U_{cf}}. \quad (5)$$

TABLE I. MAIN DATA OF FUEL CELL SYSTEM

Symbol	Parameter	Value	Unit
E_0	Ideal voltage	1.18	V
K_{O_2}	Molar constant of oxygen valve	249×10^{-5}	Kmol / (s atm)
K_r	Modelling constant	993×10^{-7}	Kmol / (s atm)
K_{H_2}	Hydrogen valve constant	832×10^{-6}	Kmol / (s atm)
K_{H_2O}	Water valve constant	277×10^{-6}	Kmol / (s atm)
F	Faraday's Constant	96487	C/mol
τ_{H_2O}	Time response of water flow	78.3	s
τ_{H_2}	Time response of hydrogen flow	26.1	s
τ_{O_2}	Time response of oxygen flow	2.91	s
r_{H-O}	Hydrogen oxygen flow ratio	1.145	
U_{cf}	Fuel cell utilization	0.85	
τ_f	Time response of fuel processor	5	s
I	Initial current	100	A
P_{rated}	Rated power	2	MW
T	Operating temperature	1273	K
N_0	Number of cells in series per stack	3500	
R	Ohmic losses	0.126	Ohm
T	Absolute Temperature	850	K
t_e	Electrical response time	0.8	s

The SOFC operates efficiently when U_{cf} is between 0.7 and 0.9. The output voltage of the FC, V_{dc} , is given by:

$$V_{dc} = E_{cell} - V_{\Omega} - V_{act} - V_{con}, \quad (6)$$

where V_{Ω} is the ohmic voltage drop, i.e.

$$V_{\Omega} = I R_{\Omega}, \quad (7)$$

where R_{Ω} is the ohmic resistance and I is the load current; V_{act} is the activation voltage drop, caused by the activation energy before the chemical reaction occur, i.e.:

$$V_{act} = \alpha + \beta I, \quad (8)$$

where α is the Tafel constant and β is Tafel slope; V_{con} is the concentration voltage drop, i.e.:

$$V_{con} = \frac{-RT}{2F} \ln \frac{I}{I_L}, \quad (9)$$

where I_L is the limiting current density corresponding to a surface concentration value of zero [22].

By controlling the FC with a specific level of power output, the flowrates of hydrogen, oxygen and water can be measured from the model. These values are used to design the tank size for the specific track segment. The reaction time of the FC is the critical limiting factor, as otherwise the intervention of the grid is necessary every time the railway load varies.

III. CONTROL OF STATIONARY FUEL CELL SYSTEMS FEEDING AN ELECTRIC RAILWAY

A numerical simulation of a section of electric railway supplied by a SOFC system has been developed to prove the functionality of the system and assess the benefits for a use case of a branch line in the UK.

The power demand of each train has been obtained from the railway simulator with a rolling stock used for suburban metro services. The chosen line is a route close to the city of Birmingham, as in [8], with the track elevation shown in Fig. 3. The power demand is shown in Fig. 4, indicating a maximum power requirement of 550 kW and a cruising power of 100-150 kW, which can be assumed as the required average power.

Considering an allowance of 10% to take into account power losses due to the mechanical transmission and power conversion, the power demand will be at 165 kW on average and 605 kW at its peak. Considering a distance between the

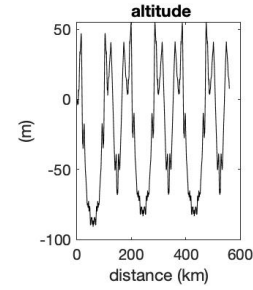

Figure 3: Elevation of the Birmingham route for a whole day operation

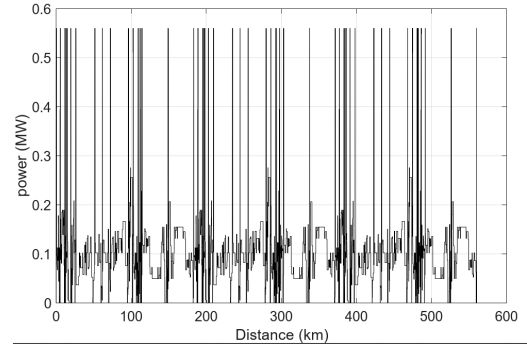

Figure 4: Simulation of the traction power requirement of a train

feeder stations of 50 km [23], 1 train every 10 min, and 2 tracks, the average and peak power demands of each feeder station are 660 kW and 2,420 kW, respectively. The peak value has been chosen as design power of the SOFC, whereas the average power has been used to evaluate the size of the tank. For simplicity, in this paper the design of the tank does not consider CHP auxiliary units and the procedure will be refined at a later stage.

To design a system configuration compatible for various use cases, all possible operational models and boundary conditions have been prepared [24]. A MATLAB code with various lookup tables enables the definition of the baseline for the system configuration, which has been validated for the track segment based on the results from [8].

The simulated traction power demand profile provides the input for the SOFC model, where the response time and the gas flow rates can be measured as described before. The control of the hydrogen flow rate and the operational control strategy to minimize the grid load is the target of the holistic control strategy. The required hydrogen flow is controlled from the power demand with a PID controller that regulates the position of the valve in the pipe feeding hydrogen to the SOFC.

In order to assess the SOFC reaction time, 2 events in a short interval of 30 sec have been analysed from the simulation, as shown in Fig. 5 and Fig. 6. As shown the actual power output marked in blue is following the power reference, which has been assessed by the train simulator model and delivers the required power output with a delta. The MATLAB Simulink model is designed to simulate a delta in reference and actual power demand to allow a simulation of an overload condition as the stationary FC needs to be powered according to the time schedule to reduce the energy consumption and grid dependency. For scenarios with no trains, the reference will reduce the power generation of the SOFC accordingly. To allow the model to react on any power reference and actual power requirement, the PID controller has been tuned to cover all scenarios, which does lead to the delta in the actual simulation result. The partial pressure of hydrogen, oxygen, and water has been plotted in Fig. 7 and Fig. 8 for the 2 cases, where the overall hydrogen consumption can be calculated at a later stage.

The first case shows a train's acceleration from standstill, followed by a period of field-weakening and cruising. The second case represents instead a bit more random variations of the traction power due to the presence of multiple trains and operating in different conditions. The simulations show that in both cases the SOFC responds with a good dynamic, and so the grid power is very limited. The measured hydrogen

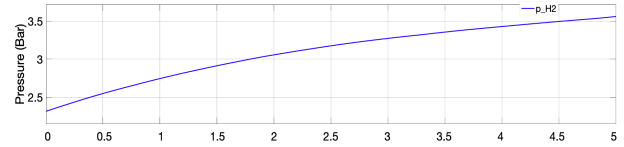

Figure 5: Pressure of media for case 1

pressure behaviour confirms that the SOFC power supply is adequate for use in railway traction systems, as system has pressure always larger than 2.5 bar for the chosen operational temperature, which is the minimum required for stable operations [25]. In future studies, an overload of the SOFC system will be simulated to show the power limitation capabilities of the controller, while a higher contribution from the grid will provide the shortfall of power required by the trains.

IV. SOLUTION FOR NOT ELECTRIFIED TRACKS | COMPARISON WITH HYDROGEN TRAINS

This section compares the proposed technology based on stationary SOFCs to hydrogen trains with an onboard PEM FCs. The target is to assess which solution is the most appropriate for lines that are currently not electrified [2]. As indicated in Section I, hydrogen and hybrid trains have an additional weight compared to electric trains to accommodate the FC, the hydrogen tank, and the battery. The FC power system weight can be assumed equal to 15-20 kg/kW [26] and, using a max train power of 550 kW [27], the additional weight of the FC would be 8-11 tonnes. The energy consumption has been calculated using the railway simulator and, considering the train locomotive weight without the tank of 100 tonnes [8].

Using as a reference the electric train and the railway line in section III, it can be estimated that a hydrogen train would have an additional weight of 11 tonnes, while a hybrid FC battery train would have an extra weight of 41 tonnes to maintain the same acceleration profile.

When calculating the total energy demand, the recuperation potential during braking operations as well as the weight of the fuel was not considered. Assumptions on the auxiliary have been made and added to allow a fair comparison from a system weight perspective.

TABLE II. ENERGY CONSUMPTION OF HYDROGEN AND HYBRID TRAINS IN COMPARISON TO ELECTRIC TRAINS

Application	Energy demand [kWh]	Tractive effort [kN]
Electric train weight 100 t	937	98
FC only train weight 111 t	957	109
Hybrid FC train weight 141 t	1011	138

The results of the simulation, shown in Tab. II, indicate that hydrogen trains consume 2-3% more energy than electric trains, while hybrid FC trains consume 8-11% more energy. This leads also to the fact that both trains need a higher tractive effort to compensate for the extra weight which would add an additional weight for the larger electric motor, which has also not been considered here. Assuming a

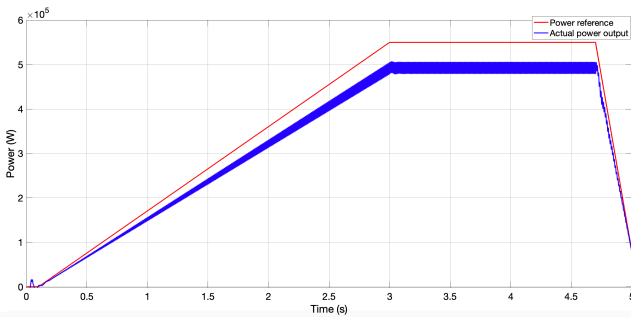

Figure 6: Comparison between the traction power demand and SOFC power for case 1

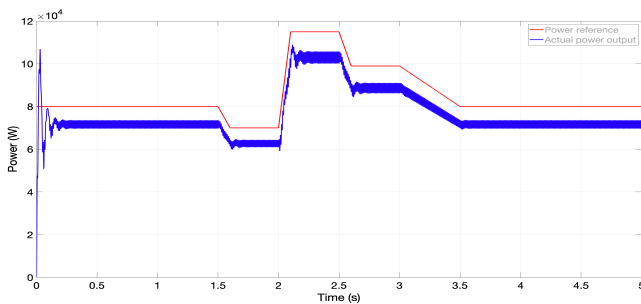

Figure 7: Comparison between the traction power demand and SOFC power for case 2

hydrogen consumption of a locomotive of 0.82 kg/km [2] and the 550 km Birmingham route, this would lead to a hydrogen consumption reduction potential of 50 kg per train per day. Under the assumption that 20 trains are operating 365 days per year, 365 tonnes of hydrogen can be saved per year using the proposed electrification system. Within 10 years this would result into additional fuel cost of 11-29m€, considering a cost of hydrogen of 3-8 €/kg [28].

Assuming an investment for a FC hybrid electric train of 4m€ [29] and the infrastructure to ensure the refilling, an additional 90-100m€ of investment would be needed for 20 trains.

According to [30] the electrification of 50 km of track would cost between 50-100m€. Without considering the increased efficiency as well as the reduced refilling and maintenance cost, the stationary SOFC application compared to a mobile PEM application can be seen as a profitable investment as shown in the following business case assumption. As reported in [31], SOFC power plants have been significantly improved in the last years which makes them a highly efficient and cost-effective solution. Considering a net investment cost of SOFCs between 700–1,100 €/kW, would lead to an investment of 1.4 - 2.2m€ per SOFC i.e. a total of 2.8- 4.4m€ to install two, 2MW SOFC applications. According to these figures, the stationary SOFC would be approximately 26m€ cheaper than the hydrogen train solution, considering the usage of the existing electrical train fleet. The reduced energy consumption supports the business case, as the investments are comparable. This calculation will be extended in the future by consider more in depth the CHP and efficiency parameters.

Depending on the track configuration and the operating train model, the authors of [32] have developed a model to calculate the cost for the operations (OPEX) as well as the capital expenditure (CAPEX), comparing the Diesel, FC and catenary electric drive. Using a total cost of ownership method, the mobile FC systems are competitive with the catenary electrification. The efficiency of the stationary SOFC with the CHP potential as this has not been assessed.

V. CONCLUSION AND FUTURE WORK

This paper reports on the development of the system configuration and the power control to support the decarbonisation of branch lines that are not immediately in the scope of electrification programmes. A decentralised, demand-oriented and grid independent power supply has been proposed for the supply of electric railways using stationary SOFCs fed by green hydrogen. The hydrogen can be produced in the vicinity of feeder stations with renewable power sources or delivered by trucks or pipelines.

The proposed layout not only enables a reduction in CAPEX and OPEX, but also provides a technical solution based on the existing electrification network and technology. To achieve this goal, it is critical to ensure that the reaction time of the FCs can follow the variation of the train demand, which can be simulated with MATLAB and based on the input requirements coming from a train simulator model. In the paper, this has been achieved by regulating the pressure and the flow of hydrogen, while keeping the temperature of the FC constant. The aim is to propose a self-contained

system where the generation of hydrogen, the energy storage and energy transformation to electrical energy will be considered and defined, to propose an ideal system configuration that is competitive to the existing and planned railway operation configurations.

By designing the FC system and the tank according to the requirements of the track segment and considering the expected amount of hydrogen generated by the local renewable energy sources, it is possible to design a railway electrification system which is mainly grid independent.

Adopting the solid-oxide technology for the FCs, the supply of electricity can be usefully complemented with the supply of heating for buildings in the vicinity of the railway. Such a co-generation approach increases the efficiency of the system and reduces the operating cost of the railway.

To optimise the operations of the systems, the following key influencing factors need to be considered:

- Track segment average demand per day
- Variation of demand due to specific events
- Energy transformation losses (e.g. seasonality effects)
- Safety buffer to run a limp-mode of trains
- Weather forecast based on historical information
- Evaluation of special weather conditions
- Energy transformation efficiency
- Design of tank volume to with adequate reserve of hydrogen

These aspects will be addressed in future work by improving the model of the system and introducing the power generation from renewable sources [31]. Especially on the power conversion side, the control of the SOFC considering all performance aspects will be the biggest challenge in order to reduce the investments and to decrease the dependency on the grid which would also reduce the overall OPEX of the railway industry and support the decentral energy generation approaches. By providing dates and figures, which prove the reduction of OPEX and CAPEX for the railway operations, this will not only be an attractive solution for all stakeholders and will deliver successfully and sustainable on the decarbonisation targets.

VI. REFERENCES

- [1] R. Kahn et al, "Transport and its infrastructure," Cambridge University Press, Cambridge, 2007.
- [2] Y. Ruf et al, "Study on the use of Fuel Cell and Hydrogen in the railway environment," Publications office of the European Union, Luxembourg, 2019.
- [3] US Department of Energy, "Office of Energy efficiency & renewable energy," 2019. [Online]. Available: <https://www.energy.gov/eere/fuelcells/hydrogen-storage>. [Accessed 02 01 2020].
- [4] International Energy Agency, The future of Rail | Opportunities for energy and the environment, International Energy Agency, 2019.
- [5] Alstom, "Coradia iLint – der weltweit erste Wasserstoffzug," Alstom, 01 01 2018. [Online]. Available: <https://www.alstom.com/de/our-solutions/rolling-stock/coradia-ilint-der-weltweit-erste-wasserstoffzug>.

- [Accessed 10 12 2022].
- [6] J. Bischoff, "Alstom presents its battery-powered multiple unit train in Saxony," 07 09 2021. [Online]. Available: <https://www.alstom.com/press-releases-news/2021/9/alstom-presents-its-battery-powered-multiple-unit-train-saxony>. [Accessed 04 03 2022].
- [7] A. Hoffrichter, "Well to Wheel analysis for electric, diesel and hydrogen traction for railways," University of Birmingham, Birmingham, 2012.
- [8] S. Hillmannsen, "Single Train Simulator," University of Birmingham, Birmingham, 2013.
- [9] A. Hoffrichter et al, "Conceptual propulsion system design for a hydrogen-powered regional train," University of Birmingham, Birmingham, 2015.
- [10] B. Sorensen, *Hydrogen and Fuel Cells*, Roskilde University: Elsevier, 2012.
- [11] E. Achenbach, "Response of a Solid Oxide Fuel Cell to Load Change," *Journal of Power Source*, vol. 57, no. 1-2, pp. 105-109, 1995.
- [12] C. Wang and H. Nehr, "A Physically-Based Dynamic Model for Solid Oxide Fuel Cells," *IEEE*, vol. 22, no. 4, pp. 1-4, 2006.
- [13] Y. Zhu and K. Tomsovic, "Development of Models for Analyzing the load Performance of Micro Turbines and Fuel Cells," *Elsevier*, vol. 62, no. 1, pp. 1-11, 2002.
- [14] G. A. J. M. J. Padulles, "An integrated SOFC plant dynamic model for power system simulations," *Journal of Power Sources*, vol. 86, no. 1-2, p. 495/500, 2000.
- [15] Y. Li, S. Rajakaruna and S. Choi, "Control of a Solid Oxide Fuel Cell Power Plant in a Grid-Connected System," *IEEE*, vol. 22, no. 2, pp. 405-413, 10 03 2007.
- [16] V. Cigglotti and M. Genovese, "Stationary Fuel Cell Applications," IEA Technology Collaboration Programme, Coesenza, 2006.
- [17] K. C. Bhuyan et al, "Fuel Cell connected to Grid through Inverter," *IEEE*, pp. 1-4, 2012.
- [18] J. M. Guerrero and S. Golestan, "Conventional Synchronous Reference Frame Phase-Locked Loop is an Adaptive Complex Filter," *IEEE Transactions on Industrial Electronics*, vol. 62, no. 3, pp. 1679 - 1682, 2014.
- [19] A. Camacho et al, "Positive and Negative Sequence Control Strategies," *IEEE*, vol. 33, no. 6, pp. 5362 - 5373, 2018.
- [20] O. Corigliano, L. Pagnotta and F. Peteronilla, "On the Technology of Solid Oxide Fuel Cell (SOFC) Energy System for Stationary Power Generation," University of Calabria, Calabria, 2022.
- [21] D. Hall and R. Colelaser, "Transient Modeling and simulation of a turbolar Solid oxide fuel cell," *IEEE*, vol. 14, no. 3, pp. 749 - 753, 1999.
- [22] M. Ciobanu et al, *Handbook of Electrochemistry*, Nashville: Department of Chemistry, Vanderbilt University, 2007.
- [23] Fraunhofer-Institut für Windenergie und Energiesystemtechnik, *Bahnstrom regenerativ - Analyse und Konzepte zur Erhöhung des Anteils der Regenerativen Energie des Bahnstroms*, Berlin: Fraunhofer IWES, 2011.
- [24] F. Takemusa, K. Ogawa and T. Yamamoto, "Drive Control for Fuel Cell and Lithium Ion Battery Hybrid Railway Vehicle," *IEEE*, pp. 86-91, 2009.
- [25] Caroline Willich, et al., "Pressurized Solid Oxide Fuel Cells: Operational Behaviour," Deutsches Zentrum für Luft und Raumfahrt, Stuttgart, 2019.
- [26] Argonne National Laboratory, "Argonne," May 2017. [Online]. Available: https://www.autonomie.net/pdfs/ANL%2017_07%20Fuel%20Cell%20Powered%20Vehicles%20Analysis%20Report.pdf. [Accessed 02 01 2020].
- [27] A. Hoffrichter et al, "Review and assessment of hydrogen propelled railway vehicles," *IEEE*, pp. 1-5, 2010.
- [28] PwC, "The green hydrogen economy," PwC, [Online]. Available: <https://www.pwc.com/gx/en/industries/energy-utilities-resources/future-energy/green-hydrogen-cost.html>. [Accessed 04 01 2023].
- [29] Railway technology, "Corodia iLint Regional Train," Railway technology, 24 December 2020. [Online]. Available: <https://www.railway-technology.com/projects/corodia-ilint-regional-train/>. [Accessed 03 01 2023].
- [30] E. Hof, "Germany's Perspective on Hydrogen Trains," Now-GmbH.de, Brussels, 2019.
- [31] E. Fontelli et al, "Conceptual study of a 250 kW planar SOFC system for CHP application," *Journal of Power Sources*, vol. 131, no. 1-2, pp. 49-56, 2004.
- [32] A. Schwillig et al, "Study on use of fuel cell hydrogen in railway environment," Roland Berger, Brussels, 2019.
- [33] B. Sorensen, *Hydrogen and Fuel Cells*, Roskilde University: Elsevier, 2012.
- [34] Bundesministerium für Digitales und Verkehr, "Mit der Elektrobahn klimaschonend in die Zukunft – Das Bahn-Elektrifizierungsprogramm des Bundes," Bundesministerium für Digitales und Verkehr, Berlin, 2021.