

A review of metrology in lithium-ion electrode coating processes

Reynolds, Carl D.; Slater, Peter R.; Hare, Sam D.; Simmons, Mark J.H.; Kendrick, Emma

DOI:

[10.1016/j.matdes.2021.109971](https://doi.org/10.1016/j.matdes.2021.109971)

License:

Creative Commons: Attribution-NonCommercial-NoDerivs (CC BY-NC-ND)

Document Version

Publisher's PDF, also known as Version of record

Citation for published version (Harvard):

Reynolds, CD, Slater, PR, Hare, SD, Simmons, MJH & Kendrick, E 2021, 'A review of metrology in lithium-ion electrode coating processes', *Materials and Design*, vol. 209, 109971.
<https://doi.org/10.1016/j.matdes.2021.109971>

[Link to publication on Research at Birmingham portal](#)

General rights

Unless a licence is specified above, all rights (including copyright and moral rights) in this document are retained by the authors and/or the copyright holders. The express permission of the copyright holder must be obtained for any use of this material other than for purposes permitted by law.

- Users may freely distribute the URL that is used to identify this publication.
- Users may download and/or print one copy of the publication from the University of Birmingham research portal for the purpose of private study or non-commercial research.
- User may use extracts from the document in line with the concept of 'fair dealing' under the Copyright, Designs and Patents Act 1988 (?)
- Users may not further distribute the material nor use it for the purposes of commercial gain.

Where a licence is displayed above, please note the terms and conditions of the licence govern your use of this document.

When citing, please reference the published version.

Take down policy

While the University of Birmingham exercises care and attention in making items available there are rare occasions when an item has been uploaded in error or has been deemed to be commercially or otherwise sensitive.

If you believe that this is the case for this document, please contact UBIRA@lists.bham.ac.uk providing details and we will remove access to the work immediately and investigate.

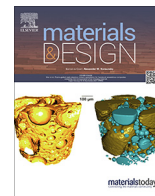

A review of metrology in lithium-ion electrode coating processes

Carl D. Reynolds^{a,d,*}, Peter R. Slater^{b,d}, Sam D. Hare^{c,d}, Mark J.H. Simmons^{c,d},
Emma Kendrick^{a,d,*}



^aSchool of Metallurgy and Materials, University of Birmingham, Elms Rd, Birmingham B15 2SE, United Kingdom

^bSchool of Chemistry, University of Birmingham, Birmingham B15 2TT, United Kingdom

^cSchool of Chemical Engineering, University of Birmingham, Birmingham B15 2TT, United Kingdom

^dFaraday Institution, Campus, Quad One Becquerel Avenue Harwell, Didcot OX11 0RA, United Kingdom

HIGHLIGHTS

- Coating of electrode inks is parameterised and metrology approaches are reviewed.
- Metrology options are comprehensive, but can be advanced e.g. in-line rheology, particle sizing.
- Reduced sensor size and cost is required for small scale studies and to develop predictive design.
- Extensive metrology must be combined to realise the goal of high quality, low-cost production.

GRAPHICAL ABSTRACT

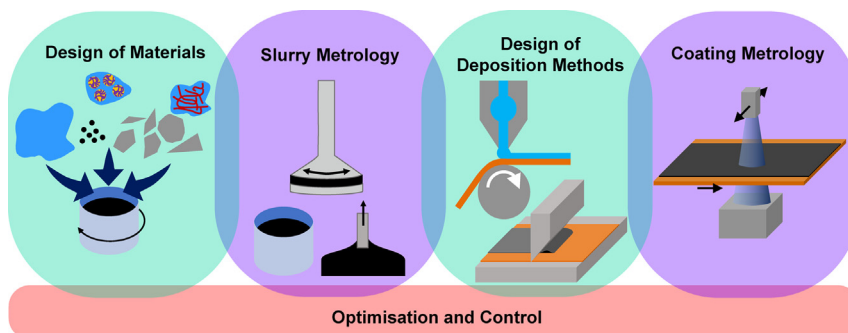

ARTICLE INFO

Article history:

Received 10 February 2021

Revised 25 June 2021

Accepted 6 July 2021

Available online 08 July 2021

Keywords:

Battery

Electrode

Manufacturing

Coating

Metrology

Measurement

ABSTRACT

Lithium-ion battery electrode design and manufacture is a multi-faceted process where the link between underlying physical processes and manufacturing outputs is not yet fully understood. This is in part due to the many parameters and variables involved and the lack of complete data sets under different processing conditions. The slurry coating step has significant implications for electrode design and advanced metrology offers opportunities to improve understanding and control at this stage. Here, metrology options for slurry coating are reviewed as well as opportunities for in-line integration, discussing the benefits of combining advanced metrology to provide comprehensive characterisation, improve understanding and feed into predictive design models. There is a comprehensive range of metrology which needs little improvement to provide the relevant quantifiable measures during coating, with one exception of particle sizing, where more precise, in-line measurement would be beneficial. However, there is a lack of studies that bring together the latest advancements in electrode coating metrology which is crucial to understanding the interdependency of myriad processing and product parameters. This review highlights the need for a comprehensive metrological picture whose value would be much greater than the sum of its parts for the next generation of multiphysics and data-driven models.

© 2021 Published by Elsevier Ltd. This is an open access article under the CC BY-NC-ND license (<http://creativecommons.org/licenses/by-nc-nd/4.0/>).

* Corresponding authors.

E-mail addresses: c.d.reynolds@bham.ac.uk (C.D. Reynolds), e.kendrick@bham.ac.uk (E. Kendrick).

Contents

1. Introduction	2
2. Metrology of the coating process	4
2.1. Coating thickness and coat weight	4
2.2. Slurry rheology	7
2.3. Interfacial properties	8
2.4. Agglomerate size and shape	8
2.5. Coat structure and defects	9
3. Dimensional analysis and modelling	9
4. Conclusions and future challenges	10
Funding	11
Declaration of Competing Interest	11
References	12

1. Introduction

Lithium-ion electrode manufacture is a complex process with multiple stages, which all impact the microstructural design and ultimate performance of the electrode.[1] The aim of the electrode manufacturing process is to deposit onto a metallic current collector (typically aluminium for cathodes or copper for anodes), a dry (solvent free) composite coating of active material (e.g. $\text{LiNi}_{0.6}\text{Mn}_{0.2}\text{Co}_{0.2}\text{O}_2$ (NMC 622) in a typical lithium ion cathode, or graphite for an anode), mixed with small amounts of a conductive additive (e.g. carbon black) and a polymeric binder (e.g. polyvinylidene fluoride, styrene butadiene rubber, carboxy methyl cellulose) to improve adhesion and add elasticity to the coating, preventing cracking. This is currently achieved in industry, using slurry casting, the stages of this process are illustrated in Fig. 1. They are; the formulation and selection of materials, mixing of the materials into a solvent to create an electrode slurry, coating the slurry onto metal foil, drying the coated electrode to remove solvent and calendaring/compressing the dry electrode to increasing the energy density of the cell via reduction in porosity, leaving sufficient porosity for lithium transport.[1,2] The finished electrode can then be cut to size and assembled into a cell. The coating and drying steps are reported to make up around 22% of the total cost of electrode manufacture.[3] To enable predictive tools, for electrode design in manufacturing and further improve quality and reduce cost, the ability to make informed changes in the processing with no detrimental effect upon the performance is required.

At each stage in manufacture, there are numerous process variables involved, each of which can have different impacts on the output into the following stages and thus must be controlled to produce tailored electrode designs, these are summarised in Table 1. For example, a more intensive mixing (higher speeds, longer time) may more efficiently break up agglomerates, giving a slurry with a more desirable rheology (typically lower viscosity at high shear rates relevant to coating) [4,5] which can be coated

at a higher speed. However, these effects cannot be studied in isolation; continuing the example above, the higher mixing speed could also cause shear degradation of the binder, [6,7] which may then cause delamination or cracking of the coating during drying or calendaring. For a fully operational digital twin for electrode manufacturing it is therefore key to develop a full understanding of the manufacturing process, using a combination of top down (parameters vs outputs e.g. machine learning) and bottom up (developing chemical and physical understanding and models) approaches.[8–10] Advanced metrology is key to these approaches, to access key parameters at intermediate stages in manufacture, allowing effects to be separated out and mechanisms to be elucidated. If the impact of the processing steps upon the final electrode microstructural design, and ultimate performance properties are understood and can be modelled then the electrode design through manufacturing can be predicted. This step-changing and smart manufacturing method can also reduce optimisation time in manufacturing lines, saving both resources and time, as well as allow the targeting of precise microstructure by design of the manufacturing process. The drive for advanced in-line metrology and digital manufacturing is common to many industries (e.g. additive manufacturing [11,12], industrial mixing [13])

The number of variables and the potential for incorporation of new metrology measurements into the full electrode and cell manufacturing line are immense. This review concentrates upon the slurry coating stage and the metrology options available are discussed with reference to the variables and parameters specific to coating, which also feed into future machine learning and physiochemical models for predictive design and manufacturing of electrodes.

Electrode coating is a significant part of the manufacturing process with a large contribution to the final microstructure and thus is a pertinent area for the application of advanced metrology. Coating can be performed via various routes.[1] The coater may be a draw down coater (Fig. 1), which is commonly used in research labs to produce small coatings, or for larger, industrial applications, a reel to reel coater is often used. The geometry of the coater can be doctor blade (a fine blade set at a fixed gap from the foil), comma bar (a comma shaped geometry with a curved leading edge), or slot die (material is extruded out of a slot onto the foil), illustrated in Fig. 2. The coating may be applied while the foil is supported by a roller, as shown, or it can also be applied to an unsupported foil under tension, which is known as tensioned web coating (Fig. 3). Coaters can also range in size and the size of foil they can support. Currently, slot die coating is most common in industrial electrode production.[14] As well as the precise geometry of the coater used, the key parameters defining the coating process are the speed the foil is moved through the coater, the flow rate of the fluid and the tension applied to the web.

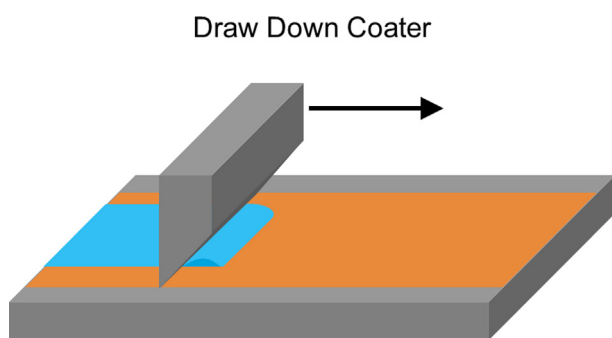

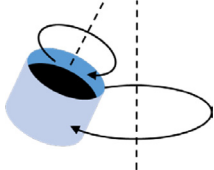
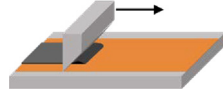
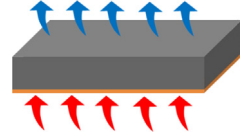
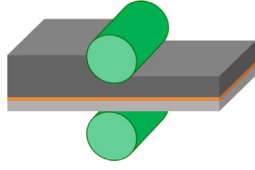

Fig. 1. Illustration of a draw down coater with a doctor blade geometry.

Table 1
Summary of the parameters involved in the electrode manufacture process.

Formulation		Mixing	Coating	Drying	Calendering				
									
Formulation Variables	Materials properties	Mixing Variables	Slurry properties	Coating Variables	Wet Coating properties	Drying Variables	Dry Coating properties	Calendering Variables	Final electrode properties
Choice of materials Ratios	Chemistry Particle size Polymer chain length Polydispersity	Surface tension Rheology Density Weight or Volume fraction Agglomerate size Structure	Mixer type Rotational speed Temperature Shear and extension rates	Coater type Coater dimensions Coating speed Coating gap Shear and extension rates Web tension Temperature	Thickness Coatweight Defects Adhesion Structure Areal distribution of properties	Dryer type Time Temperature Zones Air flow	Thickness Coatweight Defects Adhesion Pore/Component structure Areal distribution of properties	Gap Pressure Speed Temperature	Thickness Coatweight Defects Adhesion Pore/Component structure Wetting Electrochemistry Areal distribution of properties

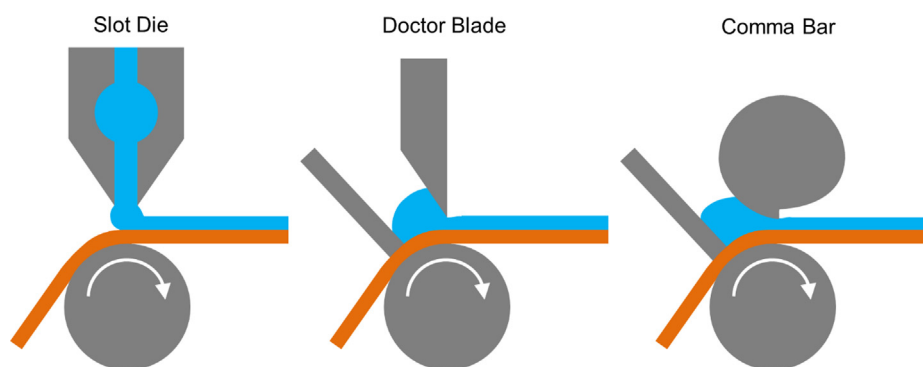

Fig. 2. Illustration of slot die, doctor blade and comma bar coating geometries on a reel to reel coater.

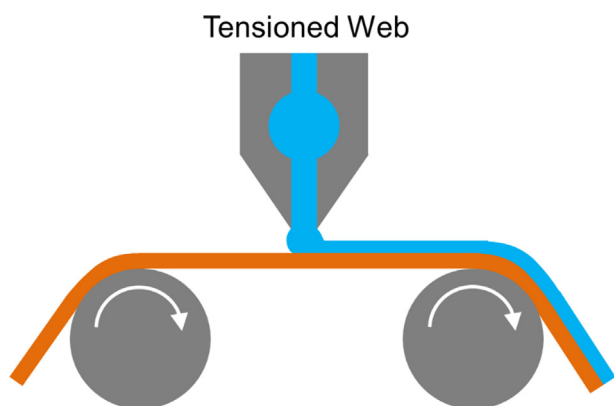

Fig. 3. Illustration of a tensioned web coater.

Slot die coating is pre-metered, i.e. a pump supplies the slurry material, and the flow rate determines the volume of slurry applied to the coating. Doctor blade and comma bar geometries are self-metered, the doctor is supplied to a reservoir (either manually or by a pump) and the geometry determines the volume allowed onto the substrate.

There are also novel coating techniques under development such as spray coating [15,16] electrophoretic deposition [17,18] and 3D printing [19,20]. These allow more precise control over the coating structure and allow novel structures and patterns to be created, which can give advantageous electrochemical properties. However, they currently require relatively low solid loadings, which makes it difficult to coat thick and dense films. Hence, they are not yet used for large scale production. This review will focus on the coating methods currently in industrial use; however, the metrology options are equally as relevant to novel coating methods.

The parameters involved in coating are given in Fig. 4, where the process parameters are those that cannot be directly controlled during the coating stage. The slurry properties and interfacial properties are defined by the materials used and the previous mixing step, however both can be measured either before or during the coating step. The properties of the resulting coat: thickness, coat weight, and the presence of defects, are outputs of the coating stage, and can be used to monitor the quality of the coating before passing it to the drying stage.

There is opportunity for advanced metrology in all of these stages, including the applied parameters, as by measuring them, the accuracy of the set values can be determined, as well as the influence of any uncertainty on the resulting coating (for example, for high precision gap measurements, a microprobe system can be

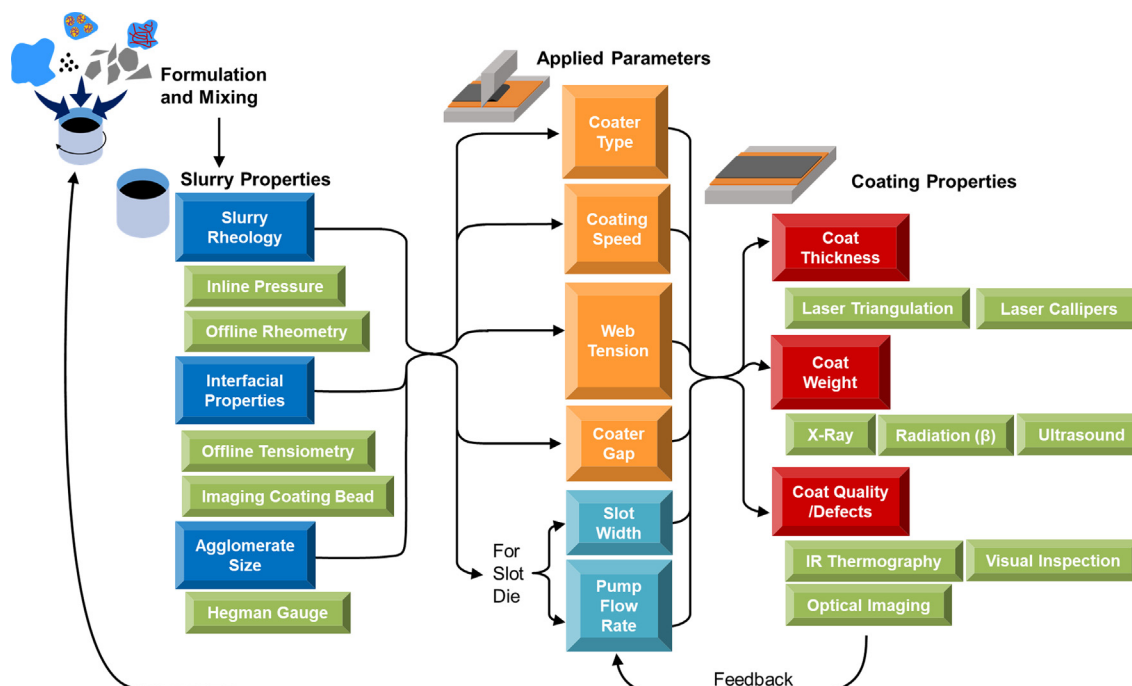

Fig. 4. Parameters involved in the coating process and in green, the metrology options available at each stage. (For interpretation of the references to colour in this figure legend, the reader is referred to the web version of this article.)

implemented [21]). This review will focus on the coating stage specifically and seeks to bring together recent advances in metrology that can be combined during coating and on the wet coated substrate to better characterise and understand the process. The ultimate aspiration would be to fully digitise the coating apparatus, so that the link, and interdependencies between the input and output parameters can be determined to create a digital twin, so that real time control can be enacted with minimal human input. This work reviews the current input and output parameters and the metrology that is currently used to monitor them, and assesses the progress towards this goal.

2. Metrology of the coating process

As Lithium-ion electrodes are manufactured industrially, the process is a developed field with a multitude of options for monitoring the process, however these are often used in isolation, as quality control measures. There is significant value in combining metrology approaches to advance our understanding of the process, enable predictive design and move towards a digital twin.

Offline methods offer a basic understanding of the coating process and are common in research labs and industry alike. For example, slurry properties can be measured before coating, and the coat can be assessed after coating e.g. sampling and weighing the coated electrode versus the uncoated substrate to obtain an estimate of the coating weight. However, in-line methods offer various benefits. They give the ability to survey more of the coating than taking sample points and often offer improved detection of faults in the coating. Rapid in-line measurements of key parameters offer the opportunity for real time process control, enabling conditions to be optimised during the process to obtain the desired coating properties, leading to less stoppage time and wastage.

Advanced metrology also provides a pathway to achieve digital twins of manufacturing processes and the goal of Industry 4.0. The fourth industrial revolution is dependent on four design principles, interconnection, information transparency, decentralised decision making and technical assistance [22]. These principles are being

taken up in many areas (e.g. chemicals [23,24], additive manufacturing of parts [25] and catalysts [26]), and helping to drive advancement in manufacturing. The implications of this for metrology, are that not only is advanced metrology required, but it also must be interconnected to make data available to the rest of the manufacturing apparatus, and the data used to make decisions without or with minimal user input (e.g. a feedback loop with coating speed or gap control). Metrology is a key element in the development of cyber-physical systems, controlling physical apparatus (such as the coating systems described) using computer algorithms. This is highly desirable as it can reduce the time needed to make adjustments to optimise the process (e.g. for new formulations). It also reduces the human intervention needed and lowers the potential for error, saving time and reducing material wastage (e.g. relying on an operator to spot irregularities in coating, which may vary between operators, versus having a set of criteria to define this consistently based on measured inputs). The scrap rate in lithium ion electrode is reported to be around 2% [27] contributing around 6% of the overall battery cost [3], which becomes very significant as production is scaled up in giga factories, and there is significant scope to reduce this through better inline metrology (e.g. quick identification of defects allowing for adjustment of parameters to make the coating uniform). Metrology is also vitally important for modelling, as collection of data at all stages of manufacturing is required to model the process accurately, and create digital twins that can predict the results and be used to optimise the manufacturing process and develop the algorithms needed for in-line control.

In the following sections, the available metrology options will be reviewed for each of the coating process parameters; thickness and weight, agglomerate size and shape, slurry rheology, interfacial properties and defect recognition as identified in Fig. 4.

2.1. Coating thickness and coat weight

One of the key parameters when producing any coating is the **coating thickness** achieved. This is key to electrode production,

as thicker electrodes contain a greater amount of active materials, increasing energy density, but also have greater diffusion distances, lowering power output, as well as potentially causing uneven response across the electrode and leading to quicker degradation.[28] Hence there exists an optimum thickness to balance these effects, and control over the thickness is important. Electrode coatings also undergo calendaring (i.e. compression) and knowledge of the thickness before and after this step is used to calculate the porosity of the final electrode coating, which is another key variable in dictating electrochemical properties. Coating thickness measurement options are summarised in Table 2.

Thickness can be measured offline e.g. using a dial gauge [29,30] or micrometer [31] after coating and drying, wet thickness can also be measured offline using a wet film comb. However, on large scale production, this trial and error approach can lead to much bigger wastage and equipment downtime. These also have the downsides of being single point measurements, so regular sampling of electrodes can be time consuming and miss variations. Therefore in-line methods are required in industrial production to ensure target thicknesses are met.

One method to measure the thickness is using laser position sensors.[32–34] With a motor to control the coater position, these can be used in a feedback loop, adjusting the gap between the coater and substrate to achieve the desired coat thickness without stopping the coating process. The placement of these sensors can vary and be used in different ways; measuring the thickness of the wet coating can give insight into the coating process, whereas thickness after drying would give a better quality control measure for the final electrode.

Another important point about laser triangulation is that it provides different measures for transparent and opaque surfaces. For transparent coatings, coat thickness can be measured directly from the different scattering from the coat surface and the foil surface (and in the case of a transparent substrate, its thickness can also be measured). However, for opaque materials the laser is only scattered from the top surface of the coating, and so triangulation only measures the distance between the sensor and the surface. To measure coat thickness, a measurement on bare foil is required to calibrate this output. This can be done by measuring bare foil before coating, or if the foil is not entirely covered during the coating process, the sensor can be positioned to measure across this edge.

Because laser triangulation systems can scan over a relatively wide area, they can be used to create a thickness profile. Schmitt *et al.*[35] demonstrated the use of a system with capability to scan over a 7 mm width every 36 ms, with an accuracy of 1 μm and repeatability of 0.2 μm . This allowed topographic scanning of the wet coating and the identification of defects. By creating a thickness profile along the coating, edge effects (e.g. thickening near the edge of coating) can also be studied.[14]

To further increase the range of coating that can be profiled, a traversing frame can be used, which moves side to side over the sample. These are commonly employed with a variety of different measurement sensors. They allow a profile of the coating to be measured, however for an in-line system, as the coating is moving through the path of the sensor, the region scanned by the sensor spans a zig-zag path. The extent to which this is a problem will depend on the speed of the reel and the traversing frame (which is itself limited by the speed of the measurement). For fast reel speeds or slow movement of the sensor on the frame, large sections could be missed. However, if the reel speed is slow and the movement of the frame fast, a nearly complete 3D profile of the coating can be built up (see Fig. 5).

Laser callipers [36] are a slightly different application of this technology, where a similar laser sensor is placed above and below the foil, each measuring the distance of the web from the sensor. If the sensors are aligned and the distance between them is known, the exact thickness of the material passing between can be extracted. This gives much better accuracy than triangulation but over a more localised area. It is also very sensitive to the alignment, and hence, it is difficult to move the lasers once aligned. The authors suggest this concept could be combined with triangulation, having a laser triangulation system on each side of the foil to create a calliper, however cost may limit this application. There is also potential to combine a calliper with a fibre optic displacement probe, which could be calibrated to the more accurate calliper, then allow measurement over a wider area.

For transparent substrates, a laser measurement is not even required, a system that works on the transmission of light through the coated substrate (using the Beer-Lambert law) can be achieved with a LED and a digital camera. Here, coloured dye was added to the coating to distinguish it from the transparent substrate, and a calibration was performed on different thicknesses, allowing an accurate thickness measurement (down to 1 μm).[37] This type of measurement can also use near-IR radiation, if the coating and substrate allow sufficient radiation through [38], however this can be difficult for typical electrode materials.

Different systems have also been demonstrated for more specialised applications. For very thin coatings ($O(10^2)$ nm) an in-line ellipsometer could be implemented.[39] Chin *et al.*[40] showed a design of a coater with an in-line spectrometer after the drying oven to measure the dry thickness of silicon based coatings.

Thickness measurement is well explored and existing methods work well, however there is usually a compromise between high accuracy and the ability to scan over large areas of film. Hence the main opportunity for advancement in thickness measurement would be the development of a high accuracy, traversing sensor (e.g. by the calliper/triangulation combination suggested by Moharty [36]) in a package that is robust, inexpensive and easy to implement on existing lines. There are also opportunities to

Table 2
Comparison of coat weight measurement options.

Coat Weight Measurement		
Method	Advantages	Disadvantages
Radiation (e.g. X-ray, Beta)	<ul style="list-style-type: none"> High accuracy Can be integrated inline 	<ul style="list-style-type: none"> High cost Radiation requires safety measures Requires sensors both sides of the foil More sensitive to movement and vibrations
Backscattering	<ul style="list-style-type: none"> Single sided sensor – easier to integrate/traverse Lower cost 	
Ultrasound	<ul style="list-style-type: none"> No radiation Can be integrated inline 	<ul style="list-style-type: none"> High cost Requires sensors both sides of the foil
Near-IR	<ul style="list-style-type: none"> No radiation Can be integrated inline 	<ul style="list-style-type: none"> Requires sensors both sides of the foil Difficult to use on opaque samples/substrates

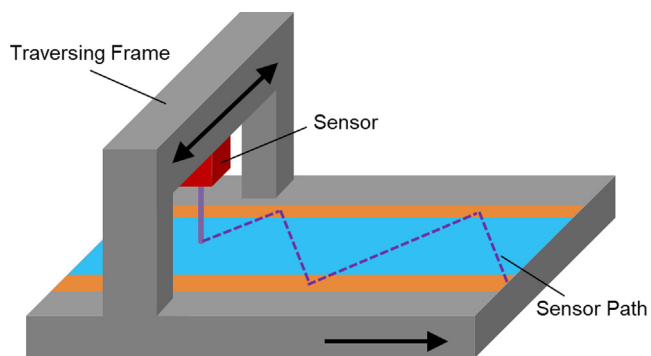

Fig. 5. Illustration of the zig zag path of a sensor in a traversing frame.

combine with other metrology options, such as the measurement of coat weight.

Coat weight, i.e. the mass of coating applied per unit area, is another important parameter in the coating process. The mass of active material per unit area dictates the final capacity of the electrode and while higher coat weights are desirable to increase energy density, they typically also lower the power density. Hence there needs to be a compromise between the two, giving the maximum energy density while satisfying the power requirements needed for the application. For this reason, specific control of the coat weight is highly desirable to reduce the tolerances that need to be left and maximise energy density.

The coat weight is linked to coat thickness, and commonly only one of thickness or coat weight is measured. If the slurry density is assumed to be constant across the coating, the other parameter can be calculated. However, there is also value in the direct measurement of both coat weight and thickness, as a combined measurement would allow the calculation of local density, which likely does vary over area and time. For example, there may be some settling in the slurry reservoir, causing a different density of components deposited over time, or the deposition process may leave areas of lower agglomerate concentration at the coating edge. Mapping this out would allow the exact knowledge of the coat weight of the area of coating being taken forward into a cell, and again could allow tolerances to be reduced and improvements to efficiency. Options for coat weight measurement are summarised in Table 3.

Measurements based on the transmission of beta radiation are one option for measuring the coat weight of the electrode, these sensors are commonly used in the paper industry [41], where a beta source is placed one side of the coated electrode and a detector on the other. The amount of radiation that reaches the detector will be proportional to the mass of material between the sensors.

Like other sensors, they can be mounted on a traversing frame to scan across the coating and obtain mass profiles. For well-known materials, where the density is known and the assumption is made that the coating density does not vary significantly across the coating, thickness can be calculated from this mass. The weight of the base material (metal foil) must also be measured separately to accurately calculate coat weight. This can be done by having sensors before and after the coating, or in the case that the coating does not fully cover the metal sheet, by comparison of the uncoated edge to the coated section.[42] Since this relies on comparison of two separate measurements each with a percentage error, the weight of substrate and coating must be of the same order of magnitude, or large errors can be introduced. Hence this, and other techniques that require comparison of bare and coated foil, are difficult for thin coatings on thick substrates.

X-ray transmission can be used in place of beta radiation in a similar setup to provide coatweight,[43] as can near Infrared (NIR), but this latter technique is more difficult to use for electrode coatings which are very opaque and allow little NIR through.

All of these methods depend on the Beer-Lambert law for attenuation of radiation through a material:

$$\frac{I}{I_0} = e^{-\mu\beta}$$

where I_0 is the incident intensity of the radiation, I is the transmitted intensity to the detector, μ is the mass attenuation coefficient (which depends on the chemical species and the energy of the radiation used) and β is the coat weight. μ can be looked up for many materials or determined by performing a calibration with several coatings of known coat weight.

A limitation of using beta radiation for coat weight is the random nature of radiative emission which means longer times are needed for a measurement to average out these effects. This limits the speed a traversing frame can move, and for the high coating speeds used in industry, can cause significant areas of the coating to be missed.

Ultrasound can also be used to measure the weight of coated material.[44] It is based on the measurement of the transmission coefficient of an ultrasonic wave, vertically perpendicular to the coat surface, using the gate technique where the sender and receiver are active for a short time, adjusted to the spatial distances so only the sound arriving is detected without reflections from the environment.[45]

As well as transmission, backscattering can also be used to measure coat weight, e.g. using gamma radiation or X-rays.[46] The amount of backscattering is proportional to the amount of material in its path, hence coat weight can be measured. This requires only a single sided sensor rather than sensors on each side, and so can be suited to smaller spaces. Like transmission, it requires comparison

Table 3
Comparison of coat thickness measurement options.

Coat Thickness Measurement		
Method	Advantages	Disadvantages
Laser Triangulation	<ul style="list-style-type: none"> • Single sided - easy to integrate inline • Can be traversed easily • For transparent systems can measure thickness directly from scattering 	<ul style="list-style-type: none"> • For opaque systems must compare to bare foil
Laser Callipers	<ul style="list-style-type: none"> • High accuracy • Can be integrated inline 	<ul style="list-style-type: none"> • Higher cost • Requires Sensors both sides of Coating • Sensitive to alignment - difficult to traverse
Laser Triangulation with Callipers	<ul style="list-style-type: none"> • High accuracy - triangulation calibrated against calliper • Can be integrated inline 	<ul style="list-style-type: none"> • High cost • Requires multiple sensors
Dial Gauge/ Micrometer	<ul style="list-style-type: none"> • Small, simple apparatus • Low cost 	<ul style="list-style-type: none"> • Manual • Offline
Light Transmission	<ul style="list-style-type: none"> • Simple Apparatus - Easy to integrate inline • Low cost 	<ul style="list-style-type: none"> • Needs opaque substrate and coloured coating

of the coated foil to uncoated to extract coat weight. However, this can be more sensitive to movement of the sample or vibrations which transmission methods are relatively insensitive to.

Like thickness, coat weight measurement has been well explored in industrial coating and various good options exist for different applications. Backscattering offers a single sided sensor (which can be important when integrating into existing coating lines with space on only one side) which can be traversed, but transmission offers greater robustness where the space is available. Radiation based methods can limit the traversing speed (and thus the area of coating measured) and will involve additional safety steps to accommodate the radioactive sources, which may limit their adoption in industry. Ultrasound largely alleviates these issues and provides an accurate measure of coat weight across the foil. However most available sensors (backscattering and transmission) are designed for industrial lines and there is scope for more compact traversing sensors to be developed to bridge the gap between research and industrial metrology.

Knowledge of the coat weight and thickness can be used to tune the coating parameters that determine them online during coating. The flow in a slot die is complex and the coat weight and thickness are determined by the slot width, flow rate, height of the slot above the substrate and the coating. The slot dimensions are usually fixed, unless multiple heads are available and cannot be adjusted on the fly, and it is undesirable to lower the coater speed. Hence the flow rate of slurry and height of the die are the most useful for optimisation, where flow rate can be increased to give thicker/higher coat weight coatings as required, and height may need to be increased in order to maintain the slurry dimensions at the slot die head and prevent slurry backing up behind the die. Even in simpler doctor blade coating, the gap does not fully dictate the final wet thickness, as the slurry is viscoelastic, and will elastically rebound, giving a thicker coating than the gap setting. The extent of this will be affected by the coating speed; faster rates will give larger elastic effects. Here the coater gap is most useful for optimisation, as again it is undesirable to drop coat speeds as this lowers output.

The optimum configuration for study of coating density, would be a both an in-line thickness and coat weight sensor, both traversing across the coating to create on-line profiles of the density across the coating. This would allow on-line control by feeding coat weight, thickness and density back to the coating speed and gap. There is additional value in making these measurements both before and after drying. Comparing the wet thickness to the applied gap will give information about the elasticity in the process. The dry coat weight will dictate the capacity of the coating and so will be the ultimate factor to optimise by changing the gap and speed. The change in coat weight and thickness during drying can be used (with knowledge of the slurry formulation) to determine whether the slurry is fully dry.

2.2. Slurry rheology

Rheology is highly important to the coating process and is determined by microstructural properties of the coating, defined by the materials used and the previous mixing step.[6,47] It can affect the coating process in various ways, if the viscosity at the coating shear rate is too high, the coating may become unstable, giving a coating with undulations or blocking the coater completely. In pumped systems (i.e. slot die coating), the viscosity (at the shear rates created in the tubing and in the die), will dictate the pressure in the system at a given flow rate, and the pressure limits of the system may dictate the maximum flow rate that can be used, which can limit the speed of coating. The rheology can also impact the structure of the coating. Typically, these high weight fraction slurries are on the border of gel like behaviour

(i.e. their elastic and viscous moduli are similar, indicating they exhibit both rubbery and flowing behaviour). Hence some slurries may behave in a more elastic manner, e.g. retaining alignment of components from previous shear leading to difference in conductivity, swelling or bouncing back after coating to give thicker coatings than expected from the coating geometry. Thus, the degree of viscoelasticity is an important property to understand, and will also link with the interfacial properties, discussed later, as either surface or rheological effects can dominate coating flows depending on the magnitudes of each.

Rheology is most commonly measured offline, although the tests performed may vary. The simplest way to quantify the effect of rheology is to perform a viscosity measurement at a shear rate relevant to the coating process. However, these shear rates are large and can vary hugely, e.g. 3000–100,000 s⁻¹ for slot die and 20–40,000 s⁻¹ for blade coating.[48]

Estimates for the apparent shear rates involved in coating can be calculated with the following equation for blade coating:

$$\dot{\gamma} = \frac{v}{h}$$

where v is the coating speed and h is the gap between the blade and the foil.[49] For slot die coating the equation becomes:

$$\dot{\gamma} = \frac{6Q}{bh^2}$$

where Q is the volume flow rate, b is the slot width and h is the height of the slot above the foil.[50]

Standard rheometers cover very little of the range of shear rates encountered in coating (typically $O(10^{-1} - 10^3) \text{ s}^{-1}$), so often a shear rate is picked that represents the lower limit of the coater, and it is assumed if the viscosity is low enough at this point then it will flow in the coater. If a sweep of shear rates is performed, extrapolations of the viscosity to higher shear rates can be performed, e.g. assuming the material follows power law behaviour. Alternatively, capillary rheometers [51] can be used to reach the higher shear rates encountered in coating, but these are more complicated to use and clean, as well as requiring large amounts of sample.[35]

As well as shear rheology, extensional rheology may be important to electrode coating. For example Yang *et al.* showed that in blade coating, extension rates at the blade entrance were of the same magnitude as shear rate. [52] Hence looking at the shear response alone may not be sufficient to understand the coating behaviour. Extensional properties can be measured using rheometers such as the capillary breakup extensional rheometer[53] or by applying approximations for entry flow[54] to capillary rheometer measurements, but this is currently rarely applied to electrode slurries.

It is also possible to get a measure of the slurry rheology in-line, through measurements of the pressure in the system. The pressure that builds up in the coater will be directly determined by the rheological properties of the slurry and some rheometers (e.g. capillary rheometer, multi-pass rheometer[55,56]) use pressure difference measurements over a known geometry, to measure rheology of the material, some with slot geometries[57] very similar to the slot die. It is important to note that while the pressure difference drives the flow and is a consequence of the slurry rheology and flow rate, the absolute pressure values in the coater could also have an impact on the slurry microstructure and could be considered a separate variable.

It has been demonstrated that there is a linear relationship between pressure in the coater and the thickness of the resulting coating.[58] Schmitt *et al.*[59] also studied intermittent die coating and found that the system pressure within the die correlated very well with coat thickness and that a steady pressure was required

for a homogenous coating. This is most important for intermittent coating as in a continuous process the start-up will only affect the first part of the coating. Pressure sensors can be also used in the material reservoir which feeds back to the coating speed, to keep pressure within a desired range and avoid instabilities.[60]

Although the rheology is often considered static, it is also important to understand the age dependence of the slurry rheology. The stability of these high weight fraction slurries can vary greatly with formulation and so needs to be understood, as in coating, settling out of material in the reservoir can cause coating properties to change over time. In-line pressure measurements can account for this age dependence by measuring variations over time. Alternatively, age dependence can be quantified by studies of the rheology over time, to measure any change in properties within the timescale of a coating run.

The main opportunity for measurement of slurry rheology is the improvement of the data extracted from in-line differential pressure measurements. Computational studies of the flow in slot die coaters could be undertaken to develop rules for extracting the shear rate and viscosity from pressure measurements, and as the flow involves both shear and extensional elements, perhaps the extraction of extension rates and extensional viscosity as well. There may need to be additional pressure sensors integrated into the experimental setup to achieve this. There could also be scope to include inline rheometers to extract viscosity at different shear rates, or perform oscillatory measurements in-line, similar to off-line rheometers. Hence there are many opportunities for the extraction of more data, but even getting a single viscosity, in-line, at a shear rate relevant to the coating process, would be a big step forward and allow for quality control of the slurries, as well as feedback and rheology-dependent adjustment of the coating settings.

2.3. Interfacial properties

As well as the flow properties of the slurry, its **interfacial/surface properties** are also important, as instabilities in the coating flow can also arise from capillary effects. According to Young's equation, the three energies that will dictate the contact angle of the slurry on the current collector are the surface tension between the slurry and air, the interfacial tension between the current collector and the slurry, and the free energy of the current collector (which may be assumed to be constant for a given material). If the contact angle is too high, the slurry is prone to beading, leading to defects (i.e. holes) in the coating, whereas if it is too low, the slurry will spread on the surface, making it difficult to achieve a well-defined coating. There is evidence that lowering surface tension reduces electrode cracking, and some of the issues with aqueous electrodes compared with those based on NMP are attributed to the higher surface tension of water versus NMP.[61] Like the rheology, these properties are a function of the materials used and their distribution throughout the slurry (dictated by the mixing step and subsequent handling). While they are typically an output of the formulation and mixing, they can also be measured during the coating step, where they have significant impact.

In coating, it can be assumed that the most important surface effects will occur at the coater head although there is also a possibility for the interfacial tension between the slurry and the materials of the coater (e.g. tubing/slot die/blade) to have an effect and how the slurry flows past those sections. Surface properties can be measured offline, using tensiometers to measure surface tension of the slurry [62], or a goniometer to measure contact angles of slurry on the current collector, or of other liquids (e.g. electrolyte) on the coated electrode.[63] Again, there are opportunities for implementing measurements in-line, most commonly by imaging the coating bead (the point at which the slurry contacts

the foil) and analysing its shape, which can be used to extract values of surface and interfacial tensions.

Lin *et al.*[64] used an in-line optical microscope to observe the coating bead, i.e. the contact point between the coating and the substrate at the slot die head. The shape of the coating bead and position of the upper and lower meniscus can be related to capillary and Reynolds number and used to predict the stability of the coating.[65,66] It is also useful for coating of multiple layers as the interface between them can be studied if they are optically distinguishable (in this case TiO₂ was added to one layer to change the colour). They also observed defects by visual inspection, both of the coating head to observe dripping, and of the coating to observe air bubbles and ribbing (flow instability). This inspection was made easier as the PVA coatings were transparent and coated onto a transparent PET substrate.

Optical microscopy has also been demonstrated inline on tensioned web coating. The coating bead was imaged through the substrate, again enabled by the transparent PET.[67,68] It has also been demonstrated in both horizontal and vertical slot coaters.[66]

The surface tension is key to any visco-capillary model of flow (whether empirical or multi-physics), and it is likely that the interfacial tension between the slurry surface is also a key variable, although there are few systematic studies on how much either value varies with slurry formulation/substrate, so there is scope for more study of this area. If there is little variation between mixes, then offline measurement and optimisation of the interfacial properties may be sufficient. However, to make a fully adaptable coating setup, it would be useful to expand the use of imaging the coating bead, which is relatively simple to integrate into existing setups (a simple camera may suffice). This would be useful to predict defects before they occur, but there is more scope for study into how, when a 'bad' coating bead shape occurs, other coating parameters may be optimised to bring this back into the coat-able region. Thus, it has potential to be an important part of a feedback and control system, and the development of digital twins.

2.4. Agglomerate size and shape

Although the previous sections have mainly concerned the bulk properties of the slurry, it is of course a multi-component mixture, and the properties of the individual components can influence the flow. Chief among these is the size of the aggregates in the slurry, as if this approaches the size of the coating gap, frictional effects can occur (increasing pressure involved and causing coating defects) or the coating can be made impossible. The shape of the particles in the slurry can also have a large impact on the coating behaviour and final electrochemical properties.[69]

In practice, highly accurate measurement is not usually required, as, due to polydispersity, any aggregates on the same order of magnitude of the coating gap are undesirable. Hence this is commonly quantified manually using a Hegman gauge. These are tapered channels in a steel block, that a sample can be scraped along, giving a visible change when the depth of the agglomerates exceeds the depth of the channel.[70] As well as giving limited information (no size distribution or shape information), this has the drawback of being prone to user error (e.g. differences in speed the sample is scraped along the channel or where the user determines the visual change to have occurred). The size of the agglomerates can also be dependent on shear (breaking up at higher shear rates) and while the Hegman gauge is a relatively good analogue for a doctor blade coater (albeit with channel edges that will cause additional shear), the exact shear rate could vary hugely from the coating process (especially comparing to fast industrial coaters). A more detailed technique could be desirable, to understand the size and shape distribution of agglomerates in the slurry, and in-

line to understand how the coating conditions affect the agglomerates (e.g. their shear rate dependence). There is opportunity for innovation here as current techniques e.g. light scattering, struggle with the highly opaque slurries and in-line measurement would be ideal (e.g. on the material in the coating bead or on the wet coating after deposition). Ultrasound based particle sizing is one possibility [71], as it removes the dependence on light passing through the sample and has been demonstrated on particle slurries [72], but work would be required for optimisation to complex electrode formulations, and integration into the coating process.

2.5. Coat structure and defects

The structure of the coating and the presence of defects is another area that can impact the performance of an electrode and is important to control. There are a huge number of defect types that can occur on coated substances and these must be minimised e.g. trapped air bubbles causing voids, unstable flow causing undulations (ribbing), cracks forming while drying.[48] All of these can have different implications for electrode performance, so it is important that they are monitored (and usually, minimised). The options for defect detection are summarised in Table 4.

Measuring coat thickness, as discussed, is one example of how defects can be identified, for example, a void could be spotted as a thinner area of the coating. A high resolution, 3D profile of the coating would be optimum for detecting the presence of irregularities, but can be difficult to realise in practice, and requires the analysis of a large amount of data to extract this information. Coat weight could be used in a similar way, as defects are also likely to cause changes in mass (either due to local thickness or density variations). The gold standard would be a full map of both parameters, giving the local density across the coating. However, these measurements are usually not made continuously, but rather in multiple 2D sweeps (because of the balance between reel speed and speed of the traversing frames). Hence using them to spot defects may lead to the omission or incorrect classification of several types of defect. So there exist a variety of independent ways to measure defects in the coating.

Perhaps the most obvious is the use of visual inspection. Many lines rely on a trained eye to tune the coating properties (e.g. flow rate of coating/reel speed) to avoid defects and obtain a uniform coating. However, this may lead to differences in coatings produced by different users, and this optimisation will have to be performed each time changes are made to the materials and coating parameters, so there are potential gains in developing an automated method for performing this step, or even improving predictive capabilities so this step could be eliminated.

One way this process can be automated is by imaging the coated foil e.g. with an inline CCD camera.[34] Khandavalli et al. [73] used a high speed camera to image the die head and image the coating. Through this method they were able to study various

defects in the coating such as ribbing and trapped air. However, a transparent substrate (PET) and fluids were selected (e.g. PPG, Silicone oil), so they could image through the substrate, and a different setup would be required for opaque coatings and metallic foils relevant to industrial electrodes.

IR thermography[36] has also been demonstrated as a way of characterising the coating immediately after drying. In pinhole and divot defects, the metal foil is more exposed and so they will retain less heat, whereas blisters or agglomerates will allow less heat to escape. Hence an IR image of the coating can highlight defects. Large areas of coating can be imaged relatively quickly in this way. IR thermography can also be used, with calibration, as a thickness measurement, although it is a function of both the thickness and density of the material, and so while it highlights defects well, it can be difficult to extract true thickness values.[74]

Park *et al.*[75] used several methods to investigate adhesive slot die coatings. They used visual inspection to identify the presence of bubbles and dripping, as well as using increased flow rates and slower coating speeds to give a uniform coating. They removed strips of coating using adhesive tape to produce thin, well defined sections along the coating and used interferometry to measure thickness and map it into 3D images to study the structure.

There are also various in-depth techniques that can be applied offline once the coating has been manufactured. For example, Raman spectroscopy has been used to map the distribution of active materials in both cathode and anode coatings.[76] This technique measures over a relatively small area (~10 μm) so is less suited to identifying large defects but can provide a unique fingerprint for a type of electrode that can be used for quality control. Microscopy on different scales (e.g. optical[77], SEM[78,79]) can also be used to image coatings to identify microstructural changes. These all give more detailed information about the coating microstructure, which can be informative for adjustment of the coating parameters. However, again these are performed offline and usually require quite lengthy measurements on a relatively small area, so are less suited to providing in-line control of the process and defect detection.

Like the imaging of the coating bead, a relatively simple camera setup would be highly useful to detect the presence of defects in the coating. This would need some work in optimising the setup to maximise the resolution obtained and area scanned (e.g. may need a traversing frame if sufficient detail cannot be obtained in an image of the entire foil width). With such a setup, there is then scope to automate the detection of defects using image recognition and machine learning techniques. If defects are identified above a threshold, this can be fed back to adjust coating parameters, such as slowing coating speed, and provide enhanced coating control.

3. Dimensional analysis and modelling

For all of the parameters discussed, there is potential to use the metrology for feedback control of coating parameters, but this

Table 4
Comparison of defect detection options.

Defect Detection		
Method	Advantages	Disadvantages
Visual Inspection	<ul style="list-style-type: none"> • High accuracy and adaptability with trained users • No equipment required 	<ul style="list-style-type: none"> • Manual • User dependent
IR Thermography	<ul style="list-style-type: none"> • Quantitatively highlights defects • Consistent • Can be automated 	<ul style="list-style-type: none"> • High cost • Must be done after the oven on heated films
Optical Imaging	<ul style="list-style-type: none"> • Simple apparatus • Consistent • Can be automated 	<ul style="list-style-type: none"> • Complex software required for image analysis / defect identification

requires a good understanding of the relationships between input parameters and the coating outputs, which are not simple, and require experimental or modelling approaches.

One way in which these parameters measured via different metrology options can be combined to make predictions of the coating process is through dimensional analysis. Here, parameters are combined, seeking to remove the units and thus dependencies on the precise experimental setup, leaving dimensionless numbers that have a physical meaning.

Through the introduction of dimensionless numbers and the mapping of experimental results, the physical processes that govern behaviour can be predicted given the processing conditions. Areas of differing behaviour can be identified and mapped out (e.g. the onset of coating defects), to create predictive plots. Thus, outputs such as coat quality can be predicted based on the input parameters, or inversely, parameters can be extracted to maintain a given coat quality (e.g. the maximum speed possible without creating coat defects). The key point about using this approach is that not only can they be transferred to other systems, but that it is based on physical principles, and therefore the relationships devised are not just useful during manufacturing, but also give key insights into the physical processes occurring and can be linked with the physio-chemical properties and structure of the materials used.

Schmitt *et al.*[35] performed slot die coating experiments and observed the onset of defects, mapping these experiments using the capillary number:

$$Ca = \frac{\eta v}{\sigma}$$

Where η is the viscosity, σ is surface tension and v is the speed, here the roll speed of the slot die coater is used. The capillary number, if too high, can cause air entrapment and thus periodic defects, thus high-speed coating, high viscosity slurries, or low surface tensions can introduce these defects. Schmitt plotted the capillary number against the dimensionless gap width:

$$G^* = \frac{G}{H}$$

Where G is the coating gap and H is the wet film thickness. Higher values of this parameter lead to instability in flow and thus defects such as barring (alternating areas of coated/uncoated substrate). This can be induced when the coating speed is too high or feed rate of material to the coater is too low.

Creating a plot of Ca vs G^* allowed the identification of distinct regions where horizontal and vertical defects were present in the film, and thus the definition of a coating window in which homogenous films can be obtained. [14,59,80]. Coating windows can of course be defined using the process parameters (e.g. web speed, gap), but the use of dimensionless numbers provides additional physical insight, as well as windows that are transferrable between different apparatus and coating setups. This is vitally important as the ability to predict this defect free region will allow adaption of the coating apparatus to new formulations, and having well defined rules for this prediction will allow the development of algorithms for in-line control, required to create cyber-physical systems.

As well as relying on experiments to predict this coating window, physical models can also be used to define these relationships. A comprehensive review of the physical theories being used to predict coating window for slot die coaters is provided by Ding *et al.*[81] As well as prediction of the defect-free region, these models can suggest ways to improve the coating process, e.g. the discovery that a differential pressure across the slot die can expand the coating window to higher speeds, and the introduction of vacuum pressure to apply this.[82,83]

The majority of these approaches assume uniformity in the slurry, modelling it as a Newtonian fluid or sometimes incorporating non-Newtonian rheology (e.g. power law fluid). This does not consider the interactions of the multiphase components during coating, which can be done by considering phases separately. One example is the work of Azbarzadeh *et al.*[84], using computational simulations to model a particle laden flow in a slot die coater. The key numbers that dictate the characteristics of the flow are the bond number, the capillary number and the Reynolds number, which indicate the influence of gravity, surface tension and viscosity respectively. They modelled the liquid and particles separately, using a visco-capillary model for the fluid flow, with a constant viscosity (Newtonian behaviour). They also assumed a dilute solution where the fluid properties were not changed by the particle loading (which would not necessarily be the case for concentrated electrode slurries). They then added van der Waals forces to the particles moving through this flow, which caused particles to agglomerate, although these could be broken up at higher speeds. In their model the key parameters were the volume fraction, particle size and density, web speed, fluid viscosity and density and contact angles at the die edge and web surface. Understanding the particle behaviour is important, for example, to predict stripe defects, which occur when a large particle or agglomeration hits the coating gap, leaving an area of uncoated substrate.

Through approaches like this that add complexity to the model gradually, based on knowledge of physical processes, the origins of the bulk properties and final coating results can be explored. However, with so many parameters involved, it demonstrates the need for metrology to validate and apply such models to real systems.

It should be noted that the coating process is only one part of battery manufacturing, and the impact of the coating process on the final cell cannot be evaluated without also incorporating the effects of slurry mixing, drying, calendaring, and cell assembly. As well as the final cell electrochemistry, there are metrology options later in the process that can be used to measure the success of the coating, and these would be vital to include in a full model of the manufacturing process. For example, measurement of the adhesion of the coating to the current collector, which is highly dependent on the distribution of components (particularly binder, less near the current collector causes lower adhesion[85]), and will be a function of the slurry formulation, mixing, coating and drying. By building up the metrology available and data output (and available to researchers) at each stage, steps can be made towards fully understanding this complex process, and so more effectively realising high quality, low cost electrode production.

4. Conclusions and future challenges

Electrode design is key for the optimisation of battery properties such as power, cycle life and energy. The ability to control in real time the microstructures of the coating, would be a step-change in manufacturing. Coating currently makes up a large proportion of the cost and time spent during cell manufacturing, and reducing line optimisation times is a key area where cost and time savings can be made. To enable this design control, the parameters involved in the coating, such as the rheological properties and the impact of the ink and electrode structures upon the physical coating parameters need to be greater understood. These parameters, can be used in multi-physics or data driven models to predict design, and also help to monitor and control the coating process. The first step, is to identify and measure all the parameters involved in coating accurately. This review describes a wide range of metrology options and options for their integration in-line, in order to maximise the data that can be extracted and the opportunities to improve the process including:

- **Coat Thickness** measurement is highly useful, wet thickness can be used to calculate the dimensionless gap, a key parameter for predicting the effects of elasticity and the onset of defects. Dry thickness can be key to cell construction, especially in multilayer coatings where it can contribute more significantly to the overall dimensions of the electrode and thus change the spacers required. Comparing the wet and dry measurements can be used to study the drying process and ensure the coating is fully dry. This is a standard current measurement in manufacturing, but the addition of in-line control can aid responsive manufacturing. It is most commonly measured with laser position sensors, either single sided, measuring the difference in height between coated and uncoated film but leading to variations if the reel position fluctuates, or in the more accurate double-sided calliper configuration, which can be more difficult to traverse. Because of the downsides of each of these configurations, there is an advantage in combining the two for a traversing measurement, which is robust and can be calibrated to a high accuracy. However, this is a fairly complex and costly setup, so there is also scope for novel methods to be introduced which can also provide these benefits.
- **Coat Weight** measurement of the dry electrode is key to the final electrode capacity, but is also ideally measured both after drying and on the wet coating after deposition. In combination with thickness this allows the local density to be mapped across the film and consequently the detection of defects. Coat weight is also a standard measurement, measured by transmission of beta radiation, X-rays, or ultrasound through the coating, which are all fairly robust and able to be traversed across the coating. However, it is rarely combined in traversing measurements with thickness, to extract local density.
- **Slurry Rheology** is key to understanding the pressures involved and the stability of the coating flow, both of which may limit maximum coating speed. It can be quantified most thoroughly offline, but viscosity can be also be extracted using in-line differential pressure readings. There is scope for advancement in the in-line measurement to provide more of the benefits of an offline rheometer, e.g. application of an oscillating signal to extract viscoelastic properties.
- **Interfacial Properties** are also important to understanding the flow and will dictate how the slurry spreads (or beads up) on the current collector. Both interfacial and rheological effects must be considered in (multi-physics or data driven) models of the coating flow. These properties may be quantified through surface tension and contact angle measurements offline, which provide conventional measures easiest to feed into multi-physics models or by inline imaging of the coating bead in slot die coating, which provides interfacial information most relevant to the coating flow.
- **Particle Size and Shape** needs to be controlled to reduce friction and defects when the agglomerate size and coating gap are of similar magnitudes. Currently this is a simple manual measurement to ensure the slurry is coatable (using a Hegman gauge), but there is opportunity for innovation to bring this inline and obtain more detail on size distribution. However, limited information about the shape and its effects are incorporated into the measurements and analysis and so this merits further work.
- **Coat Quality**, whether measured by visual inspection, variation in thickness/coat weight, or imaging techniques, is important to record. Understandably, data are not often reported when things go wrong and coat defects occur, but this is highly useful information to predict the onset of such effects and minimise them in practice. Digital image analysis could provide more information upon defect analysis, and relay these back to the manufacturing parameters.

In combination, these parameters give a thorough quantification of the coating process which can be fed into multi-physics and data driven models, which lead to a significant array of future challenges and opportunities for coating. There is a large and growing library of metrology options available for electrode coatings, however there are still areas which require further investigations. One such area is in the ability to monitor or measure particle size and shape, particularly for high weight solid content inks and pastes, for which there is an outstanding challenge for the development of a reliable method to measure these highly opaque and viscous formulations, especially for in-line process control. In-line conductivity measurements may offer opportunities here. Other key aspects required to advance metrology for LiB electrodes is the interconnection of the metrology and processing equipment. The link between multiple metrology options that will allow the full parameterisation of the electrode coating process, and elucidation of the dependencies of the output on these process parameters. Whether these dependencies are to be predicted via semi-empirical methods, physical models or via machine learning, access to the entirety of the data collected is required, as well as all processing conditions, ideally with the ability to control these conditions, one example being the future development of cyber-physical systems. The simultaneous real-time collection of all these data is highlighted as an area to be developed, as well as models that can make use of this large quantity of data and react to changes. To incorporate a greater number of metrology options, for improved monitoring and control, miniaturisation of these technologies is required. With a traversing arm, several different metrology types and sensors could be attached, for example, ultrasound, light, Infra-red, optical – all giving slightly different information which can be collated and then the coating area mapped. To collect this array of data, small scale trials are needed on pilot plants, and research coatiers. New sensors and sensor designs are major research challenges for electrode manufacturing. Currently, the size and cost of the metrology options prohibits their use in small-scale studies, and they can only be incorporated into larger manufacturing lines. Improvements here would also encourage uptake of multi-sensor systems in industry, and thus increase the manufacturing data available.

Currently, dimensional analysis offers one method to combine the parameters gathered by experiments to give a physical meaning and allow results to be transferred between different apparatus. However, they are often studied in isolation, and because so many parameters are inextricably linked (e.g. coat weight, thickness and density) more studies are required that bring these techniques together to feed into modelling approaches, in order to develop a predictive understanding of electrode coating, required for predictive design and digitalisation of the process.

In summary, improvement in coating metrology tools, offers opportunities for greater control in the design and implementation of coatings. This approach is important not only for lithium-ion battery electrodes, but has applications in many other disciplines, such as coated paper making [70], catalysts designs [86] and printed electronics [87]. Greater access to measurements, and data, from the process will enable real-time control and optimisation of the coating process. Multi-physics and data driven models derived from this information will enable a more predictive design for electrode manufacturing.

Funding

This work was supported by the Faraday Institution NEXTRUDE project (faraday.ac.uk; EP/S003053/1, FIRG015).

Declaration of Competing Interest

The authors declare that they have no known competing financial interests or personal relationships that could have appeared to influence the work reported in this paper.

References

- [1] E. Kendrick, *Advancements in Manufacturing*, in: *Futur. Lithium-Ion Batter.*, 2019; pp. 262–289.
- [2] A.C. Ngandjong, T. Lombardo, E.N. Primo, M. Chouchane, A. Shodiev, O. Arcelus, A.A. Franco, Investigating electrode calendaring and its impact on electrochemical performance by means of a new discrete element method model: Towards a digital twin of Li-Ion battery manufacturing, *J. Power Sources*. 485 (2021), <https://doi.org/10.1016/j.jpowsour.2020.229320> 229320.
- [3] F. Duffner, L. Mauler, M. Wentker, J. Leker, M. Winter, Large-scale automotive battery cell manufacturing: Analyzing strategic and operational effects on manufacturing costs, *Int. J. Prod. Econ.* 232 (2021), <https://doi.org/10.1016/j.ijpe.2020.107982> 107982.
- [4] V. Wenzel, H. Nirschl, D. Nötzel, Challenges in Lithium-Ion-Battery Slurry Preparation and Potential of Modifying Electrode Structures by Different Mixing Processes, *Energy Technol.* 3 (2015) 692–698, <https://doi.org/10.1002/ente.201402218>.
- [5] H. Bockholt, W. Haselrieder, A. Kwade, Intensive Dry and Wet Mixing Influencing the Structural and Electrochemical Properties of Secondary Lithium-Ion Battery Cathodes, *ECS Trans.* 50 (2013) 25–35, <https://doi.org/10.1149/05026.0025ecst>.
- [6] A. Kraysberg, Y. Ein-Eli, Conveying Advanced Li-ion Battery Materials into Practice The Impact of Electrode Slurry Preparation Skills, *Adv. Energy Mater.* 6 (2016), <https://doi.org/10.1002/aenm.201600655>.
- [7] J.H. Shin, S.S. Jung, K.W. Kim, H.J. Ahn, J.H. Ahn, Preparation and characterization of plasticized polymer electrolytes based on the PVdF-HFP copolymer for lithium/sulfur battery, *J. Mater. Sci. Mater. Electron.* 13 (2002) 727–733, <https://doi.org/10.1023/A:1021521207247>.
- [8] M.-F. Ng, J. Zhao, Q. Yan, G.J. Conduit, Z.W. Seh, Predicting the state of charge and health of batteries using data-driven machine learning, *Nat. Mach. Intell.* 2 (2020) 161–170, <https://doi.org/10.1038/s42256-020-0156-7>.
- [9] M. Duquesnoy, T. Lombardo, M. Chouchane, E.N. Primo, A.A. Franco, Accelerating Battery Manufacturing Optimization by Combining Experiments, in *Silico Electrodes Generation and Machine Learning*, ChemRxiv. (2020) 1–33, <https://doi.org/10.26434/chemrxiv.12473501.v2>.
- [10] A. Turetskiy, J. Wessel, C. Herrmann, S. Thiede, Battery production design using multi-output machine learning models, *Energy Storage Mater.* 38 (2021) 93–112, <https://doi.org/10.1016/j.ensm.2021.03.002>.
- [11] H.D. Vora, S. Sanyal, A comprehensive review: metrology in additive manufacturing and 3D printing technology, *Prog. Addit. Manuf.* 5 (2020) 319–353, <https://doi.org/10.1007/s40964-020-00142-6>.
- [12] S.K. Everton, M. Hirsch, P. Stravroulakis, R.K. Leach, A.T. Clare, Review of in-situ process monitoring and in-situ metrology for metal additive manufacturing, *Mater. Des.* 95 (2016) 431–445, <https://doi.org/10.1016/j.matdes.2016.01.099>.
- [13] A.L. Bowler, S. Bakalis, N.J. Watson, A review of in-line and on-line measurement techniques to monitor industrial mixing processes, *Chem. Eng. Res. Des.* 153 (2020) 463–495, <https://doi.org/10.1016/j.cherd.2019.10.045>.
- [14] M. Schmitt, P. Scharfer, W. Schabel, Slot die coating of lithium-ion battery electrodes: Investigations on edge effect issues for stripe and pattern coatings, *J. Coatings Technol. Res.* 11 (2014) 57–63, <https://doi.org/10.1007/s11998-013-9498-y>.
- [15] X. Li, C. Wang, Engineering nanostructured anodes via electrostatic spray deposition for high performance lithium ion battery application, *J. Mater. Chem. A* 1 (2013) 165–182, <https://doi.org/10.1039/c2ta00437b>.
- [16] S.H. Lee, C. Huang, C. Johnston, P.S. Grant, Spray printing and optimization of anodes and cathodes for high performance Li-Ion batteries, *Electrochim. Acta*. 292 (2018) 546–557, <https://doi.org/10.1016/j.electacta.2018.09.132>.
- [17] P. Amrollahi, J. Krasinski, R. Vaidyanathan, L. Tayebi, D. Vashae, Electrophoretic Deposition (EPD): Fundamentals and Applications from Nano-to Micro-Scale Structures, in (2015): 1–27, https://doi.org/10.1007/978-3-319-15207-3_7-1.
- [18] B. Ferrari, R. Moreno, L. Hernán, M. Melero, J. Morales, A. Caballero, EPD of thick films for their application in lithium batteries, *J. Eur. Ceram. Soc.* 27 (2007) 3823–3827, <https://doi.org/10.1016/j.jeurceramsoc.2007.02.051>.
- [19] A. Izumi, M. Sanada, K. Furuichi, K. Teraki, T. Matsuda, K. Hiramatsu, H. Munakata, K. Kanamura, Development of high capacity lithium-ion battery applying three-dimensionally patterned electrode, *Electrochim. Acta*. 79 (2012) 218–222, <https://doi.org/10.1016/j.electacta.2012.07.001>.
- [20] D. Gastol, M. Capener, C. Reynolds, C. Constable, E. Kendrick, Microstructural design of printed graphite electrodes for lithium-ion batteries, *Mater. Des.* 205 (2021), <https://doi.org/10.1016/j.matdes.2021.109720> 109720.
- [21] S. Ito, Y.L. Chen, Y. Shimizu, H. Kikuchi, W. Gao, K. Takahashi, T. Kanayama, K. Arakawa, A. Hayashi, Uncertainty analysis of slot die coater gap width measurement by using a shear mode micro-probing system, *Precis. Eng.* 43 (2016) 525–529, <https://doi.org/10.1016/j.precisioneng.2015.09.016>.
- [22] M. Hermann, T. Pentek, B. Otto, Design Principles for Industrie 4.0 Scenarios, in: 2016 49th Hawaii Int. Conf. Syst. Sci., 2016; pp. 3928–3937, <https://doi.org/10.1109/HICSS.2016.488>.
- [23] S.V. Mohan, R. Katakojwala, The circular chemistry conceptual framework: A way forward to sustainability in industry 4.0, *Curr. Opin. Green Sustain. Chem.* 28 (2021) 100434, <https://doi.org/https://doi.org/10.1016/j.cogsc.2020.100434>.
- [24] M. Vaccari, R.B. di Capaci, E. Brunazzi, L. Tognotti, P. Pierno, R. Vagheggi, G. Pannocchia, Implementation of an Industry 4.0 system to optimally manage chemical plant operation, *IFAC-PapersOnLine*. 53 (2020) 11545–11550, <https://doi.org/https://doi.org/10.1016/j.ifacol.2020.12.631>.
- [25] J. Plocher, A. Panesar, Review on design and structural optimisation in additive manufacturing: Towards next-generation lightweight structures, *Mater. Des.* 183 (2019), <https://doi.org/10.1016/j.matdes.2019.108164> 108164.
- [26] O.H. Laguna, P.F. Lietor, F.J.I. Godino, F.A. Corpas-Iglesias, A review on additive manufacturing and materials for catalytic applications: Milestones, key concepts, advances and perspectives, *Mater. Des.* 208 (2021), <https://doi.org/10.1016/j.matdes.2021.109927> 109927.
- [27] J. Li, Z. Du, R.E. Ruther, S.J. An, L.A. David, K. Hays, M. Wood, N.D. Phillip, Y. Sheng, C. Mao, S. Kalnaus, C. Daniel, D.L. Wood, Toward Low-Cost, High-Energy Density, and High-Power Density Lithium-Ion Batteries, *Jom.* 69 (2017) 1484–1496, <https://doi.org/10.1007/s11837-017-2404-9>.
- [28] R. Zhao, J. Liu, J. Gu, The effects of electrode thickness on the electrochemical and thermal characteristics of lithium ion battery, *Appl. Energy*. 139 (2015) 220–229, <https://doi.org/10.1016/j.apenergy.2014.11.051>.
- [29] M. Mayur, M.C. Yagci, S. Carelli, P. Margulies, D. Velten, W.G. Bessler, Identification of stoichiometric and microstructural parameters of a lithium-ion cell with blend electrode, *Phys. Chem. Chem. Phys.* 21 (2019) 23672–23684, <https://doi.org/10.1039/c9cp04262h>.
- [30] ISO 534:2011, Paper and board – Determination of thickness, density and specific volume, n.d.
- [31] S. Kumagai, K. Mukaiyachi, D. Tashima, Rate and cycle performances of supercapacitors with different electrode thickness using non-aqueous electrolyte, *J. Energy Storage*. 3 (2015) 10–17, <https://doi.org/10.1016/j.est.2015.08.002>.
- [32] T.A. Trabold, R.F. Dunham, J.M. Hammond, Coating process for coating die with laser position sensors, 2004.
- [33] T.A. Trabold, R.F. Dunham, J.M. Hammond, Coating die with laser position sensors, (2005).
- [34] E.B. Guttoff, E.D. Cohen, Water-and Solvent-Based Coating Technology, Elsevier Inc., 2016, <https://doi.org/10.1016/B978-0-323-37100-1.00014-4>.
- [35] M. Schmitt, M. Baunach, L. Wengeler, K. Peters, P. Junges, P. Scharfer, W. Schabel, Slot-die processing of lithium-ion battery electrodes-Coating window characterization, *Chem. Eng. Process. Process Intensif.* 68 (2013) 32–37, <https://doi.org/10.1016/j.cep.2012.10.011>.
- [36] D. Mohanty, J. Li, R. Born, L.C. Macey, R.B. Dinwiddie, C. Daniel, D.L. Wood, Non-destructive evaluation of slot-die-coated lithium secondary battery electrodes by in-line laser caliper and IR thermography methods, *Anal. Methods*. 6 (2014) 674–683, <https://doi.org/10.1039/c3ay41140k>.
- [37] T. Horii, M.S. Carvalho, P.C. do R. de Janeiro, Ultra-thin coating with tensioned-web method and defect analysis by real-time thickness measurement method, (n.d.).
- [38] P.H. Shelley, G.J. Werner, US 7767970: Method for performing IR spectroscopy measurements to determine film coating thickness on a substrate, 2008.
- [39] F. Bammer, F. Huemer, Inline thickness measurement with imaging ellipsometry (2019) 36, <https://doi.org/10.1117/12.2531940>.
- [40] C.P. Chin, H.S. Wang, S.S. Wang, Improved coating window for slot coating, *Ind. Eng. Chem. Res.* 49 (2010) 3802–3809, <https://doi.org/10.1021/ie801900t>.
- [41] B. Yeager, New detection advancement enhances basis weight, coat weight measurement, *Pulp Pap.* 70 (1996) 455.
- [42] J. Borch, M. Bruce Lyne, R.E. Mark, C.C. Habeger, *Handbook of Physical Testing of Paper*, vol 2, Marcel Dekker Inc, New York, 2003.
- [43] Y. Azimi, M.T. Kortschot, R. Farnood, A non-destructive method for obtaining a local coat weight map using X-ray imaging, *J. Pulp Pap. Sci.* 35 (2009) 11–16.
- [44] H. Knorr, ULTRASONIC TRANSMITTING AND RECEIVING DEVICE FOR THICKNESS AND/OR GRAMMAGE MEASUREMENT, US008904874B2, 2014.
- [45] H. Knorr, Method and apparatus for non-contact determination of the weight per unit area of thin materials, (1997).
- [46] I.K. MacKenzie, Method and apparatus for measuring thickness of coating layers on substrates using backscattering of x-rays and gamma rays, (2001).
- [47] W.B. Hawley, J. Li, Electrode manufacturing for lithium-ion batteries—Analysis of current and next generation processing, *J. Energy Storage*. 25 (2019), <https://doi.org/10.1016/j.est.2019.100862> 100862.
- [48] E.B. Guttoff, E.D. Cohen, Coating and Drying Defects, Second Edi, John Wiley & Sons, Inc., Hoboken, NJ, USA, 2006, <https://doi.org/10.1002/0470044136>.
- [49] T.G. Mezger, *The Rheology Handbook: For Users of Rotational and Oscillatory Rheometers*, Vincentz Network, 2006.
- [50] A. Etienne, N. Besnard, J. Adrien, P. Tran-Van, L. Gautier, B. Lestriez, E. Maire, Quality control tool of electrode coating for lithium-ion batteries based on X-ray radiography, *J. Power Sources*. 298 (2015) 285–291, <https://doi.org/10.1016/j.jpowsour.2015.08.030>.
- [51] H.H. Winter, Capillary Rheometry, *Encycl. Life Syst. UNESCO.* (2008).
- [52] A. Yang, P. Salminen, S. Vervoort, I. Endres, H. Bachmann, Role of extensional viscosity in paper coating, *Appl. Rheol.* 21 (2011) 1–12, <https://doi.org/10.3933/ApplRheol-21-23607>.

- [53] G.H. McKinley, Visco-elasto-capillary thinning and break-up of complex fluids, (2005).
- [54] F.N. Cogswell, Converging flow of polymer melts in extrusion dies, *Polym. Eng. Sci.* 12 (1972) 64–73, <https://doi.org/10.1002/pen.760120111>.
- [55] M.R. Mackley, R.T.J. Marshall, J. Smelders, The multipass rheometer, *J. Rheol. (N. Y. N. Y.)* 39 (1995) 1293–1309.
- [56] C. Reynolds, R. Thompson, T. McLeish, Pressure and shear rate dependence of the viscosity and stress relaxation of polymer melts, *J. Rheol. (N. Y. N. Y.)* 62 (2018) 631–642. <https://doi.org/10.1122/1.5012969>.
- [57] M.R. Mackley, D.G. Hassell, The multipass rheometer a review, *J. Nonnewton. Fluid Mech.* 166 (2011) 421–456. <https://doi.org/10.1016/j.jnnfm.2011.01.007>.
- [58] S.-H. Kim, J.-H. Kim, K.-H. Ahn, S.-J. Lee, Rheological perspectives of industrial coating process, *Korea-Australia Rheol. J.* 21 (2009) 83–89.
- [59] M. Schmitt, R. Diehm, P. Scharfer, W. Schabel, An experimental and analytical study on intermittent slot die coating of viscoelastic battery slurries, *J. Coatings Technol. Res.* 12 (2015) 927–938, <https://doi.org/10.1007/s11998-015-9717-9>.
- [60] S. Mitani, T. Matsumoto, Coating machine with an adjustable nozzle and a pressure sensor, (1996).
- [61] Z. Du, K.M. Rollag, J. Li, S.J. An, M. Wood, Y. Sheng, P.P. Mukherjee, C. Daniel, D.L. Wood, Enabling aqueous processing for crack-free thick electrodes, *J. Power Sources.* 354 (2017) 200–206, <https://doi.org/10.1016/j.jpowsour.2017.04.030>.
- [62] N. Billot, T. Günther, D. Schreiner, R. Stahl, J. Kranner, M. Beyer, G. Reinhart, Investigation of the Adhesion Strength along the Electrode Manufacturing Process for Improved Lithium-Ion Anodes, *Energy Technol.* 8 (2020) 1801136, <https://doi.org/10.1002/ente.201801136>.
- [63] A. Davoodabadi, J. Li, Y. Liang, R. Wang, H. Zhou, D.L. Wood, T.J. Singler, C. Jin, Characterization of surface free energy of composite electrodes for lithium-ion batteries, *J. Electrochem. Soc.* 165 (2018) A2493–A2501.
- [64] Y.N. Lin, T.J. Liu, S.J. Hwang, Minimum wet thickness for double-layer slide-slot coating of poly(vinyl-alcohol) solutions, *Polym. Eng. Sci.* 45 (2005) 1590–1599, <https://doi.org/10.1002/pen.20454>.
- [65] Y.R. Chang, H.M. Chang, C.F. Lin, T.J. Liu, P.Y. Wu, Three minimum wet thickness regions of slot die coating, *J. Colloid Interface Sci.* 308 (2007) 222–230, <https://doi.org/10.1016/j.jcis.2006.11.054>.
- [66] H. Chang, Y. Chang, C. Lin, T. Liu, Comparison of vertical and horizontal slot die coatings, *Polym. Eng. Sci.* 47 (2007) 1927–1936.
- [67] F.-H. Lin, C.-M. Liu, T.-J. Liu, P.-Y. Wu, Experimental study on tensioned-web slot coating, *Polym. Eng. Sci.* 47 (2007) 841–851, <https://doi.org/10.1002/pen.20764>.
- [68] J. Nam, M.S. Carvalho, Flow visualization and operating limits of tensioned-web-over slot die coating process, *Chem. Eng. Process. Process Intensif.* 50 (2011) 471–477, <https://doi.org/10.1016/j.cep.2010.09.005>.
- [69] N.H. Kwon, H. Yin, T. Vavrova, J.H.W. Lim, U. Steiner, B. Grobety, K.M. Fromm, Nanoparticle shapes of LiMnPO₄, Li+diffusion orientation and diffusion coefficients for high volumetric energy Li+ion cathodes, *J. Power Sources.* 342 (2017) 231–240, <https://doi.org/10.1016/j.jpowsour.2016.11.111>.
- [70] J. V. Koleske, Paint and Coating Testing Manual: Fourteenth Edition of the Gardner-Sward Handbook, 1995.
- [71] M.J.W. Povey, Ultrasound particle sizing: A review, *Particuology.* 11 (2013) 135–147, <https://doi.org/10.1016/j.partic.2012.05.010>.
- [72] V. Stolojanu, A. Prakash, Characterization of slurry systems by ultrasonic techniques, *Chem. Eng. J.* 84 (2001) 215–222, [https://doi.org/10.1016/S1385-8947\(00\)00278-3](https://doi.org/10.1016/S1385-8947(00)00278-3).
- [73] S. Khandavalli, J.P. Rothstein, The effect of shear-thickening on the stability of slot-die coating, *AIChE J.* 62 (2016) 4536–4547.
- [74] P. Just, J. Rost, T. Echelmeyer, L. Ebert, M.A. Roscher, A method to quantify coating thickness and porosity of electrodes for lithium-ion-batteries, *Meas. J. Int. Meas. Confed.* 89 (2016) 312–315, <https://doi.org/10.1016/j.measurement.2016.04.001>.
- [75] J. Park, K. Shin, C. Lee, Improvement of cross-machine directional thickness deviation for uniform pressure-sensitive adhesive layer in roll-to-roll slot-die coating process, *Int. J. Precis. Eng. Manuf.* 16 (2015) 937–943, <https://doi.org/10.1007/s12541-015-0122-1>.
- [76] J.C. Panitz, P. Novák, Raman microscopy as a quality control tool for electrodes of lithium-ion batteries, *J. Power Sources.* 97–98 (2001) 174–180, [https://doi.org/10.1016/S0378-7753\(01\)00679-6](https://doi.org/10.1016/S0378-7753(01)00679-6).
- [77] C. Lin, D.S. Hill Wong, T. Liu, P. Wu, Operating windows of slot die coating: Comparison of theoretical predictions with experimental observations, *Adv. Polym. Technol. J. Polym. Process. Inst.* 29 (2010) 31–44.
- [78] B. Bitsch, J. Dittmann, M. Schmitt, P. Scharfer, W. Schabel, N. Willenbacher, A novel slurry concept for the fabrication of lithium-ion battery electrodes with beneficial properties, *J. Power Sources.* 265 (2014) 81–90.
- [79] J. Hassoun, K.-S. Lee, Y.-K. Sun, B. Scrosati, An Advanced Lithium Ion Battery Based on High Performance Electrode Materials, *J. Am. Chem. Soc.* 133 (2011) 3139–3143, <https://doi.org/10.1021/ja110522x>.
- [80] M. Schmitt, Slot Die Coating of lithium-ion battery electrodes, n.d.
- [81] X. Ding, J. Liu, T.A.L. Harris, A review of the operating limits in slot die coating processes, *AIChE J.* 62 (2016) 2508–2524.
- [82] J. Tanwar, M. Vinjamur, L.E. Scriven, Design principles of integrated vacuum slot arrangement, *AIChE J.* 53 (2007) 572–578, <https://doi.org/10.1002/aic.11112>.
- [83] A.E. Beguin, Method of coating strip material, (1954) US patent No. 2,681,6941954.
- [84] V. Akbarzadeh, A.N. Hrymak, Coupled fluid-particle modeling of a slot die coating system, *AIChE J.* 62 (2016) 1933–1939, <https://doi.org/10.1002/aic.15187>.
- [85] C.-C. Li, Y.-W. Wang, Binder Distributions in Water-Based and Organic-Based LiCoO₂ Electrode Sheets and Their Effects on Cell Performance, *J. Electrochem. Soc.* 158 (2011) A1361, <https://doi.org/10.1149/2.107112jes>.
- [86] R. Maggi, J.A. Martens, G. Poncelet, P. Grange, P.A. Jacobs, B. Delmon, Preparation of Catalysts VII, Elsevier Science, 1998.
- [87] N. Palavesam, S. Marin, D. Hemmetzberger, C. Landesberger, K. Bock, C. Kutter, Roll-to-roll processing of film substrates for hybrid integrated flexible electronics, *Flex. Print. Electron.* 3 (2018), <https://doi.org/10.1088/2058-8585/aaaa04>.