

Dynamic responses of railway prestressed concrete sleepers with under sleeper pads to high intensity impact loads

Kaewunruen, Sakdirat; Ngamkhanong, Chayut; Remennikov, Alex

License:

None: All rights reserved

Document Version

Peer reviewed version

Citation for published version (Harvard):

Kaewunruen, S, Ngamkhanong, C & Remennikov, A 2018, 'Dynamic responses of railway prestressed concrete sleepers with under sleeper pads to high intensity impact loads', Paper presented at The 3rd World Multidisciplinary Civil Engineering - Architecture - Urban Planning Symposium, Prague, Czech Republic, 18/06/18 - 22/06/18.

[Link to publication on Research at Birmingham portal](#)

Publisher Rights Statement:

Checked for eligibility: 24/10/2018

General rights

Unless a licence is specified above, all rights (including copyright and moral rights) in this document are retained by the authors and/or the copyright holders. The express permission of the copyright holder must be obtained for any use of this material other than for purposes permitted by law.

- Users may freely distribute the URL that is used to identify this publication.
- Users may download and/or print one copy of the publication from the University of Birmingham research portal for the purpose of private study or non-commercial research.
- User may use extracts from the document in line with the concept of 'fair dealing' under the Copyright, Designs and Patents Act 1988 (?)
- Users may not further distribute the material nor use it for the purposes of commercial gain.

Where a licence is displayed above, please note the terms and conditions of the licence govern your use of this document.

When citing, please reference the published version.

Take down policy

While the University of Birmingham exercises care and attention in making items available there are rare occasions when an item has been uploaded in error or has been deemed to be commercially or otherwise sensitive.

If you believe that this is the case for this document, please contact UBIRA@lists.bham.ac.uk providing details and we will remove access to the work immediately and investigate.

UNIVERSITY OF BIRMINGHAM

Research at Birmingham

Dynamic Responses of Railway Prestressed Concrete Sleepers with Under Sleeper Pads to High Intensity Impact Loads

Kaewunruen, Sakdirat; Ngamkhanong, Chayut; Remennikov, Alex

License:

Creative Commons: Attribution (CC BY)

Citation for published version (Harvard):

Kaewunruen, S, Ngamkhanong, C & Remennikov, A 2018, Dynamic Responses of Railway Prestressed Concrete Sleepers with Under Sleeper Pads to High Intensity Impact Loads. in The 3rd World Multidisciplinary Civil Engineering - Architecture - Urban Planning Symposium. IOP Publishing, The 3rd World Multidisciplinary Civil Engineering - Architecture - Urban Planning Symposium, Prague, Czech Republic, 18/06/18.

[Link to publication on Research at Birmingham portal](#)

General rights

Unless a licence is specified above, all rights (including copyright and moral rights) in this document are retained by the authors and/or the copyright holders. The express permission of the copyright holder must be obtained for any use of this material other than for purposes permitted by law.

- Users may freely distribute the URL that is used to identify this publication.
- Users may download and/or print one copy of the publication from the University of Birmingham research portal for the purpose of private study or non-commercial research.
- User may use extracts from the document in line with the concept of 'fair dealing' under the Copyright, Designs and Patents Act 1988 (?)
- Users may not further distribute the material nor use it for the purposes of commercial gain.

Where a licence is displayed above, please note the terms and conditions of the licence govern your use of this document.

When citing, please reference the published version.

Take down policy

While the University of Birmingham exercises care and attention in making items available there are rare occasions when an item has been uploaded in error or has been deemed to be commercially or otherwise sensitive.

If you believe that this is the case for this document, please contact UBIRA@lists.bham.ac.uk providing details and we will remove access to the work immediately and investigate.

Dynamic Responses of Railway Prestressed Concrete Sleepers with Under Sleeper Pads to High Intensity Impact Loads

Sakdirat Kaewunruen^{1,2}, Chayut Ngamkhanong², Alex M Remennikov³

¹ Birmingham Centre for Railway Research and Education, The University of Birmingham, 52 Pritchatts Road, Birmingham, B15 2TT U.K.

² School of Engineering, The University of Birmingham, 52 Pritchatts Road, Birmingham, B15 2TT U.K.

³ School of Civil, Mining and Environmental Engineering, University of Wollongong, Northfield Avenue, North Wollongong, NSW 2502 Australia

s.kaewunruen@bham.ac.uk

Abstract. Under sleeper pads (USPs) has recently been adopted as a component installed under the concrete sleepers generally to improve railway track resilience. The initial development in Europe, particularly the pilots in Austria, has been benchmarked around the world. In practice, the component has commonly been used in certain applications, mainly to moderate track stiffness in special locations such as turnouts, crossings, and level crossing. In heavy haul operation, the heavier wagons result in sturdier bogie structures, higher unsprung mass, and then higher level of wheel-rail interaction forces. With imperfect wheel or rail, the impact load imposed is rather of high intensity. Statistically, the impact load could exist over 25% of annual track load spectra. Accordingly, the application of USPs to mitigate detrimental impact load consequence on track structure is presented in this paper. A field trial aimed at mitigating rail joint impacts using the USPs with a thickness of 10mm and bedding modulus of 0.2 N/mm³ has been conducted in NSW Australia since October 2011. It was found that the track structure and its heavy-duty components were designed to cater heavy load burden of 30t axle load with rail pad stiffness of 800 MN/m (HDPE pads). This paper will present a 3D finite element model of sleepers with under sleeper pads, using LS-Dyna. The model has been validated by experimental results. Although the studies have found that the sleepers with USPs tend to have lesser flexures, the field data also confirms that a railway track with USPs could experience a large amplitude vibration, especially when excited by a high-frequency impact force. These behaviours imply that the use of USPs may have a trade-off impact that could aggravate dynamic behaviour of sleepers with under sleeper pads.

1. Introduction

It is not a myth that railway concrete sleepers are a major structural component in ballasted railway tracks. Its functions are to transfer train axle loads from the rails onto the underlying ballast and supporting system, and to secure rail gauge for safe passages of trains and rolling stocks. A common ballasted railway track and its components are shown in Figure 1 [1, 2]. Note that railway sleepers are safety-critical components. In general, there are two groups of track components: superstructure and substructure. Superstructure components include rail, fastening system, sleeper, under sleeper pad, ballast and ballast mat; while substructure counterparts are subballast, formation, geotextiles and foundation [3]. Under sleeper pads (USP) are resilient pads installed on the soffit of sleepers as an

attachment to provide additional track resiliency between the sleepers and ballast. Figure 2 shows a typical cross section of the ballasted railway track with under sleeper pad. In recent years, USP has been used widely and heavily in central Europe such as in Austria, Czech Republic and Germany. Additionally, several counties have carried out pilot trials such as in Sweden, Australia, and China. USP is made of polyurethane elastomer with a foam structure including encapsulated air voids. Three common objectives for installing USP are to moderate track stiffness; to reduce ground vibrations; and to reduce ballast breakage. USPs could reduce track stiffness in special areas such as turnout systems (switches and crossings) or tracks on bridge viaducts. The vibration of sleepers could also be isolated by the USP so that the ballast and formation are uncoupled from the wheel/rail interaction, reducing the ground vibrations affecting surrounding buildings and structures. The reduced ballast damage is accomplished by a reduction of contact pressure, and thus wears, in the sleeper/ballast interface. A more uniform load distribution is achieved by the use of USP, resulting in the reduction of the contact pressure and the smaller variations of support stiffness along the track. An application of USPs in Australia was initially trailed back in 1980s on open plain tracks. The outcome showed little improvement at the time whilst the delamination and degradation of the USP material were the key negative issues found in the field [4-12]. In recent years, the performance of the USPs has been improved through the outcomes from the test results in central Europe and in Austria, which show a promising quality and durability of USPs. Note that contradict outcome has been reported by Trafikverkets (Swedish Transport Administration). After several years of field tests, Trafikverkets reported that there has been no or very little influence of USPs on track quality improvement [13]. This could be a reason why the utilisation of USPs is not significant globally.

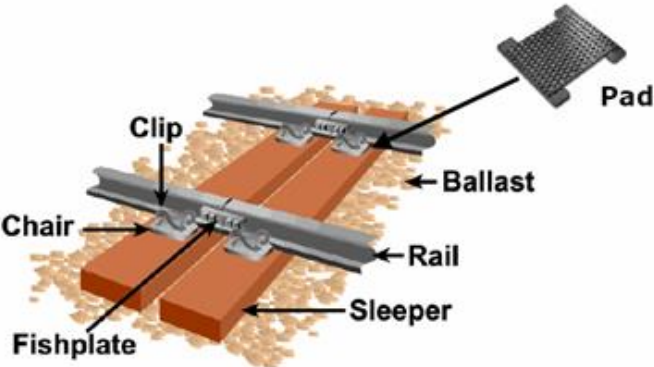

Figure 1: Typical ballasted railway track and its components [1]

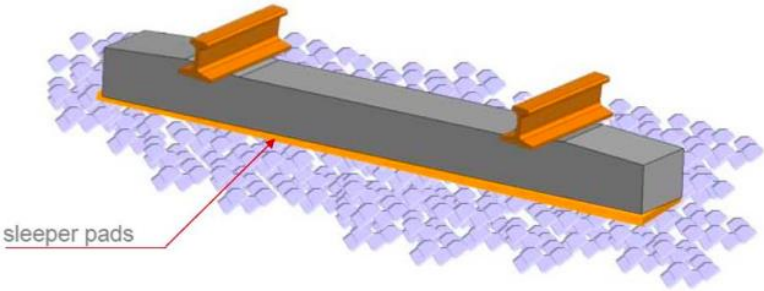

Figure 2: Under sleeper pads [4]

There are several theoretical studies and some field trials in Austria and France, which suggest that the added resiliency by USPs will attenuate impact and excessive vibration [13-20]. Consequently, it is worthwhile to trial such technology in problematic areas, for example at locations with rail surface defects, dipped joints, spark erosions, or other discontinuities in rail running surface [21]. In fact, there has never been a field trial to evaluate USP performance on short-wavelength track defects. Accordingly, a test plan for USPs has been introduced in New South Wales, Australia in order to attenuate impact vibrations at dipped rails/welds and at a glue insulated joint (GIJ) with spark erosion. Similar to other resilient mats, the USP stiffness has been designed to accommodate the differences in track properties and operational parameters. The trial in Australia is the world first to investigate the behaviour of USPs under impact loading in the field [4]. However, the numerical studies into such the behaviour is rather limited.

This paper presents the dynamic responses of railway concrete sleepers with under sleeper pads to high-intensity impact loading conditions. The study has established a 3D finite element model that can simulate and predict the responses of reinforced and prestressed concrete members. A three-dimensional nonlinear finite element model of a full-scale railway prestressed concrete sleeper for static analysis was initially developed using the general-purpose finite element analysis package, ANSYS [22-24]. The concrete section was modelled using SOLID65 solid element where the compressive crushing of concrete and the concrete cracking in tension zone can be accommodated. In the current practice, the rail-way concrete sleeper is designed to resist prestressing force fully throughout the whole cross section as the force/moment redistribution [23]. This makes the smeared crack analogy unsuitable for the replacement of prestressing tendons in the fully prestressed concrete sleeper. The use of a truss element, LINK8, for discrete reinforcement modelling, is then more practicable. An initial strain real-constant feature in ANSYS appropriately substituted the pre-tensioning forces in the tendon elements. However, it was assumed that perfect bonding between concrete and pre-stressing wires since bond slip is rarely observed under failure modes [25-27]. The static full-scale experiment was conducted to validate this FE model [24]. The experimental details were based on the European Standard [28]. The calibrated finite element model has been extended to include ballast support and in situ boundary conditions [23]. The extended model was linked to LS-Dyna for impact analysis and validation against the drop impact tests [29-31]. This study will focus on the effect of under sleeper pads on the dynamic responses of prestressed concrete sleepers.

2. Finite Element Modelling

Three-dimensional solid elements are used to model concrete material. This element is defined with eight nodes – each with three degrees of freedom: translations in nodal x, y, and z directions. To simulate the behaviour of prestressing wires, a truss element, were used to withstand the initial strain attributed to prestressing forces, by assuming perfect bond between these elements and concrete. Note that this truss element cannot resist neither bending moments nor shear forces. Non-linear elastic behaviour of concrete can alternatively be defined by the multi-linear stress-strain relationships. The modulus of elasticity of concrete (f'_c) is estimated based on AS3600 [32] using the compressive strengths (80 MPa). For prestressing wires, the bi-linear elasto-plastic material models can be used as well as the multi-linear isotropic model from the manufacturer's data. The 0.2% proof stress is 1,700 MPa and the ultimate stress is 1,930 MPa. The static and dynamic elasticity of moduli of pre-stressing wire are 190,000 MPa. The multi-linear isotropic dynamic stress-strain curve for the concrete and prestressing wires can be calculated based on the consideration of the effect of strain rate. Based on the assumption of perfect bond between prestressing wires and concrete, the dynamic material properties of concrete and prestressing wires can be determined [30, 31].

The extended finite element model was calibrated using vibration data [24, 26]. The updated finite element model was then transferred to LS-Dyna [30, 31], as shown in Figure 3. The simulation results were achieved by assigning the initial velocity to the drop mass to generate an impact event, similarly

to the actual drop tests. Comparison between numerical and experimental results can be found in Figure 4. It is found that the finite element model is fairly sufficient for use in predicting impact responses of the prestressed concrete sleepers. The trends of peak acceleration responses are quite close to each other, although there is certain phase difference.

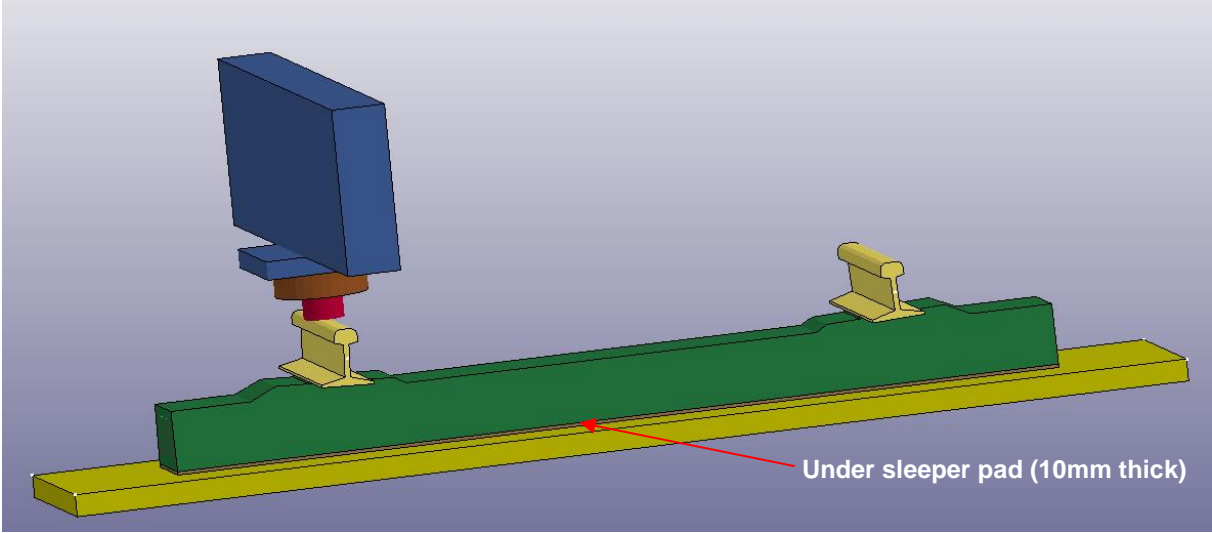

Figure 3: Nonlinear FE modelling of under sleeper pad (full-scale)

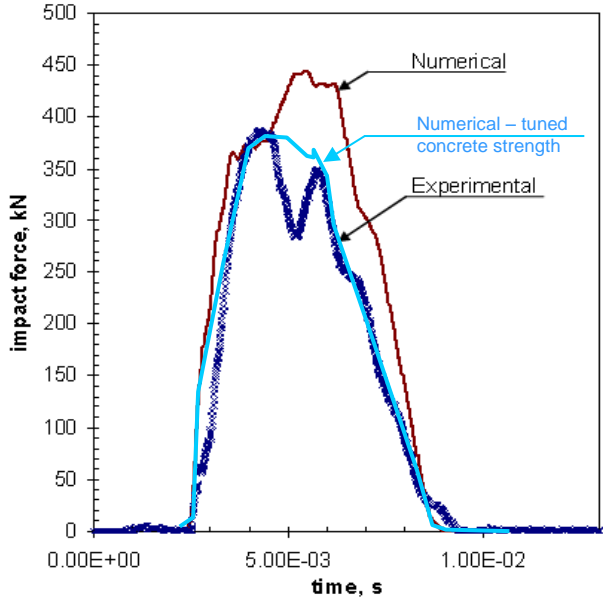

Figure 4: Contact forces between impactor and rail for model verification (no USP)

3. Results and discussions

The comparison of von-mises stresses in concrete sleepers with and without USP under an impact loading is shown in Figure 5. It is clear that the dynamic stress concentration on the concrete sleeper is much less with USP. This implies that USP can redistribute the impact load actions better along the concrete sleeper. The elastic moduli of USP are generally varied from 250MPa (soft) to 500 MPa (stiff), depending on the type of usage. In this analysis, the moduli of 250 MPa, 350 MPa, 450 MPa and 550 MPa are considered for benchmarking analysis.

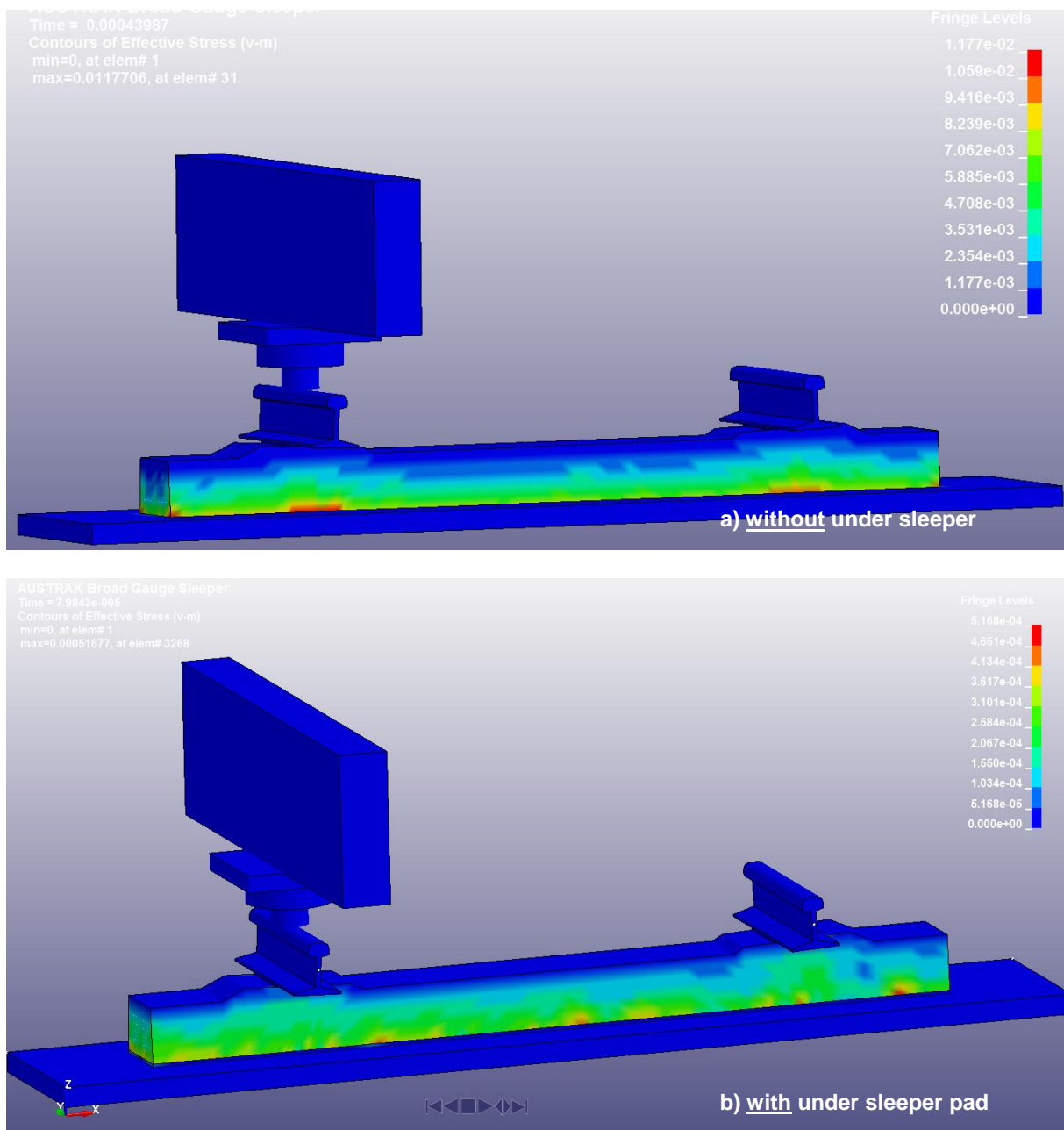

Figure 5: Impact von-mises stress distribution envelop (maximum) in concrete sleeper

Figure 6 illustrates the effects of USP stiffness or modulus of elasticity on the impact responses of the concrete sleepers. The results represent the percentage ratio of the particular response with USP over its counterpart without USP. It is quite clear that USP has positive effect on the stress distribution along the sleepers. The von-mises stress of the sleeper at railseats is alleviated under impact loading when using USP. However, the USP slightly increases the stress at mid-span. In terms of maximum dynamic displacements, the USP can reduce the sleeper displacement (vertical) as it reduces the contact force and action. Importantly, the displacements at the mid-span are significantly decreased by the use of USP. In contrast, it is very clear that the dynamic acceleration of the concrete sleepers with USP will be significantly higher. This can imply that the sleepers with USP could induce ballast dilation and possibly weaken track lateral resistance.

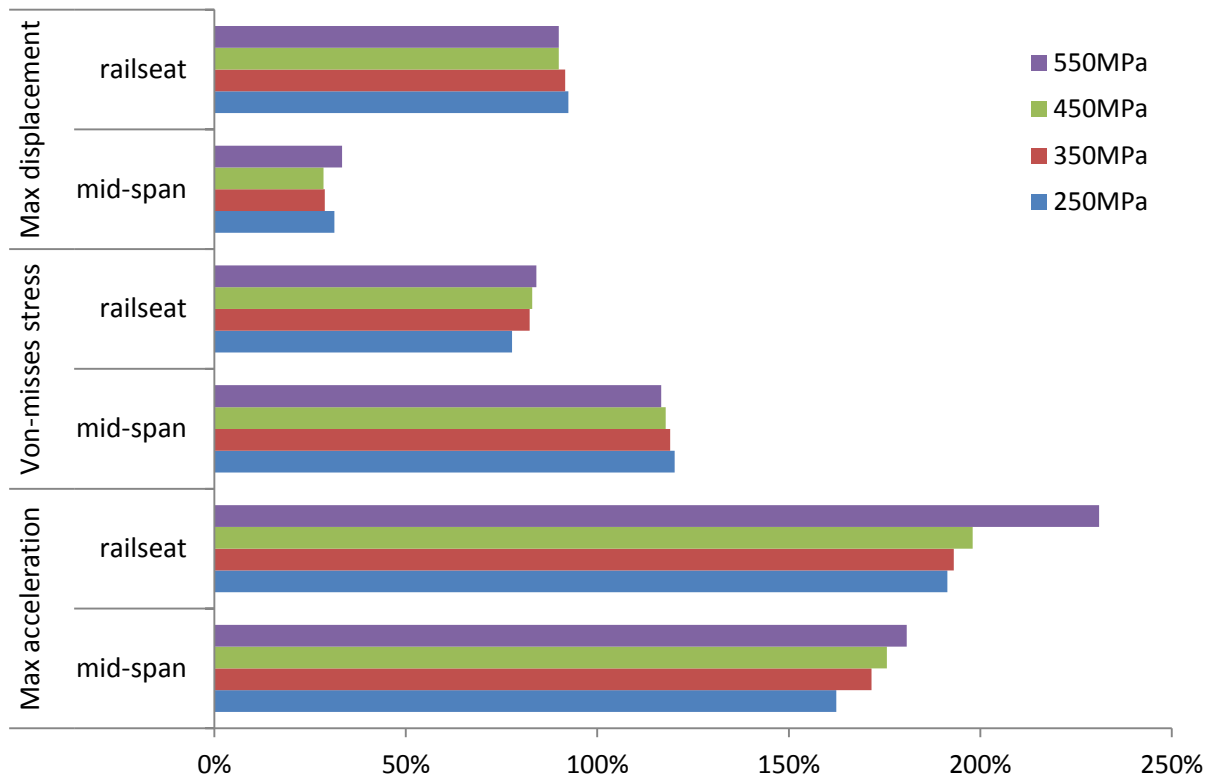

Figure 6: Effects of USP on the impact responses of railway concrete sleeper

4. Conclusions

Under sleeper pads (USPs) is relatively a new component installed under the concrete sleepers in railway tracks. They are generally used to improve railway track resilience in special locations such as switches and crossings, bridge and viaducts, rail joint, and so on. In practice, the USP has commonly been used in certain applications, mainly to moderate track stiffness. It is well known that, statistically, the impact load could exist over 25% of annual track load spectra and therefore the use of USP to suppress the impact conditions is imperative. In this study, the application of USPs to mitigate detrimental impact load consequence on track structure is presented. A field trial aimed at mitigating rail joint impacts using the USPs, which is the world first of its kind, has inspired this numerical study. The study is based on the experimental and numerical simulations of prestressed concrete sleepers subjected to impact loading. The three-dimensional finite element model have been established for investigate both static and dynamic behaviors of the railway sleepers. A commercial finite element package, LS-Dyna, has been employed to extend the model for impact analysis and it has been validated against experimental drop impact tests. The emphasis of this study is placed on the effects of under sleeper pads on the dynamic responses of railway sleeper. The results reveal that the USP will decrease stiffness of sleepers, then reduce contact forces and dynamic displacements of the sleepers. Although the studies have found that the sleepers with USPs tend to have lesser flexures, the field data also confirms with the numerical study that a railway track with USPs could experience a large amplitude vibration, especially when excited by a high-frequency impact force. These behaviours imply that the use of USPs may have a trade-off impact that could aggravate dynamic behaviour of sleepers with under sleeper pads.

Acknowledgment

The authors would also like to thank British Department for Transport (DfT) for Transport – Technology Research Innovations Grant Scheme, Project No. RCS15/0233; and the BRIDGE Grant

(provided by University of Birmingham and the University of Illinois at Urbana Champaign). The first author gratefully acknowledges the Japan Society for the Promotion of Science (JSPS) for his JSPS Invitation Research Fellowship (Long-term), Grant No L15701, at Track Dynamics Laboratory, Railway Technical Research Institute and at Concrete Laboratory, the University of Tokyo, Tokyo, Japan. The authors are sincerely grateful to the European Commission for the financial sponsorship of the H2020-RISE Project No. 691135 “RISEN: Rail Infrastructure Systems Engineering Network”, which enables a global research network that tackles the grand challenge of railway infrastructure resilience and advanced sensing in extreme environments (www.risen2rail.eu) [33].

References

- [1] S. Kaewunruen, and A.M. Remennikov, Non-destructive testing (NDT): A tool for dynamic health monitoring of railway track structures. *Materials Australia*, 39(6), 14-16 (invited), 2006.
- [2] A.M. Remennikov, and S. Kaewunruen, A review on loading conditions for railway track structures due to train and track vertical interaction. *Structural Control and Health Monitoring*, 15, 207-234, 2008.
- [3] B. Indraratna, C. Rujikiatkamjorn, and W. Salim, *Advanced Rail Geotechnology – Ballasted Track*, CRC Press, London, UK, 2011.
- [4] S. Kaewunruen, A. Aikawa, A.M. Remennikov, Vibration attenuation at rail joints through under sleeper pads, *Procedia Engineering*, 189: 193-198, 2017. doi: 10.1016/j.proeng.2017.05.031
- [5] S. Kaewunruen, J.M. Sussman, H.H. Einstein, Strategic framework to achieve carbon-efficient construction and maintenance of railway infrastructure systems, *Frontiers in Environmental Sciences*, 2015, 3:6. doi: 10.3389/fenvs.2015.00006..
- [6] S. Nimbalkar, B. Indraratna, S.K. Dash, and D. Christie, Improved performance of railway ballast under impact loads using shock mats, *ASCE Journal of Geotechnical & Geoenvironmental Engineering*, 2012, 138(3): 281-294.
- [7] S. Kaewunruen and A.M. Remennikov, Under sleeper pads: field investigation of their role in detrimental impact mitigation, *Proceedings of the 13th International Railway Engineering Conference*, Edinburgh, UK, June 30 - July 1, 2015 [CD Rom].
- [8] P. Schneider, R. Bolmsvik, and J.C.O. Nielsen, In-situ performance of a ballasted railway track with under sleeper pads, *Journal of Rail and Rapid Transit*, 2011, 225(3), 299-309.
- [9] UIC: International Union of Railway, *UIC Leaflet: Guideline for Under Sleeper Pads*, Paris, France, 2014.
- [10] M.V. Tuler and S. Kaewunruen, Life cycle analysis of mitigation methodologies for railway rolling noise and groundbourne vibration, *Journal of Environmental Management*, 2017, 191, 75-82.
- [11] R. Tavares de Freitas and S. Kaewunruen, Life cycle cost evaluation of noise and vibration control methods at urban railway turnouts, 2016, *Environments*, 3 (4), 34.
- [12] S. Setsobhonkul and S. Kaewunruen, Life cycle analysis of railway noise and vibration mitigation methodologies with respect to curve squeal noises, *Proceedings of the 45th International Congress and Exposition on Noise Control Engineering*, Internoise2016, Hamburg, Germany, 2016.
- [13] B. Larsen, Under Sleeper Pads on the Ofoten Line, *Proceedings of the 19th Nordic Seminar on Railway Technology*, Luleå, Sweden, 2016.
- [14] A. Paixão, J.N. Varandas, E. Fortunato, R. Calçada, Numerical simulations to improve the use of under sleeper pads at transition zones to railway bridges, *Engineering Structures*, in press, 2018.
- [15] H. Li, G.R. McDowell, Discrete element modelling of under sleeper pads using a box test, *Granular Matter*, in press, 2018.
- [16] L. Le Pen, G. Watson, A. Hudson, W. Powrie, Behaviour of under sleeper pads at switches and

- crossings–Field measurements, Proceedings of the Institution of Mechanical Engineers, Part F: Journal of Rail and Rapid Transit, in press, 2018.
- [17] S. Kaewunruen, Discussion of “Mitigation of Ground Vibration Generated by High-Speed Trains on Saturated Poroelastic Ground with Under-Sleeper Pads”, ASCE Journal of Transportation Engineering, 141(1): 07014003, 2015. doi: 10.1061/(ASCE)TE.1943-5436.0000708
- [18] J. Mottahed, J.A. Zakeri, S. Mohammadzadeh, Field and numerical investigation of the effect of under-sleeper pads on the dynamic behavior of railway bridges, Proceedings of the Institution of Mechanical Engineers, Part F: Journal of Rail and Rapid Transit, in press, 2017.
- [19] J.A. Zakeri, M. Esmaili, H. Heydari-Noghabi, A field investigation into the effect of under sleeper pads on the reduction of railway-induced ground-borne vibrations. Proc IMechE, Part F: J Rail and Rapid Transit, 230: 999–1005, 2016.
- [20] C. Nhamkhanong, A.T. Nascimento, S. Kaewunruen, Economics of track resilience, World Multidisciplinary Civil Engineering-Architecture-Urban Planning Symposium, IOP Conference Series: Material Science and Engineering, 2018 (accepted).
- [21] S. Kaewunruen and M. Ishida, In Situ Monitoring of Rail Squats in Three Dimensions Using Ultrasonic Technique, Experimental Techniques, 40 (4), 1179-1185, 2016.
- [22] S. Kaewunruen, A.M. Remennikov, Effect of a large asymmetrical wheel burden on flexural response and failure of railway concrete sleepers in track systems, Engineering Failure Analysis, 15(8): 1065-1075, 2008.
- [23] S. Kaewunruen, A.M. Remennikov, Experimental simulation of the railway ballast by resilient materials and its verification by modal testing, Experimental Techniques, 32(4): 29-35.
- [24] S. Kaewunruen, A.M. Remennikov, Nonlinear finite element modeling of railway prestressed concrete sleeper, Proceedings of the 10th East Asia-Pacific Conference on Structural Engineering and Construction, EASEC 2010, 4, 323-328, 2006.
- [25] S. Kaewunruen, and A.M. Remennikov, "Experimental and numerical studies of railway prestressed concrete sleepers under static and impact loads." *Civil Computing*, AIT-ACECOMS, inpress, 2007, (invited).
- [26] E.K. Gamage, S. Kaewunruen, A.M. Remennikov, T. Ishida, Toughness of Railroad Concrete Crossties with Holes and Web Openings. *Infrastructures*, 2, 3, 2017. doi:10.3390/infrastructures2010003
- [27] E.K. Gamage, S. Kaewunruen, A.M. Remennikov, T. Ishida, Reply to Giannakos, K. Comment on: Toughness of Railroad Concrete Crossties with Holes and Web Openings. *Infrastructures*, 2, 5, 2017. doi:10.3390/infrastructures2010005
- [28] British Standards Institute (BSI), European Standard BS EN13230 Railway applications. Track. Concrete sleepers and bearers, London UK, 2016.
- [29] S. Kaewunruen, and A.M. Remennikov, "Low-velocity impact analysis of prestressed concrete sleepers." *Concrete Institute of Australia's 23rd Biennial Conference 07*, October 18-20, Adelaide, Australia, 2007, [CD Rom].
- [30] S. Kaewunruen, and A.M. Remennikov, "Impact responses of prestressing tendons in railway concrete sleepers in high speed rail environments." *Proceedings of the 5th Computational Methods in Structural Dynamics and Earthquake Engineering*, May 25-27, Crete Island, Greece, 2015.
- [31] S. Kaewunruen, A.M. Remennikov and S. Minoura, "Dynamic responses of railway ultra-high-strength concrete sleepers under extreme impact loading." *Proceedings of the 6th Computational Methods in Structural Dynamics and Earthquake Engineering*, June 15-17, Rhodes Island, Greece, 2017.
- [32] Standards Australia, “Design of concrete structures” *Australian Standard: AS3600-2001*, 2001.
- [33] S. Kaewunruen, J.M. Sussman, A. Matsumoto, Grand challenges in transportation and transit systems, *Frontiers in Built Environment*, 2016, 2, 4. doi:10.3389/fbuil.2016.00004