

Two-GHz hybrid coaxial bandpass filter fabricated by stereolithography 3-D printing

Salek, Milan; Wang, Yi; Lancaster, Michael J.

DOI:

[10.1002/mmce.22501](https://doi.org/10.1002/mmce.22501)

License:

Creative Commons: Attribution (CC BY)

Document Version

Publisher's PDF, also known as Version of record

Citation for published version (Harvard):

Salek, M, Wang, Y & Lancaster, MJ 2021, 'Two-GHz hybrid coaxial bandpass filter fabricated by stereolithography 3-D printing', *International Journal of RF and Microwave Computer-Aided Engineering*, vol. 31, no. 2, e22501. <https://doi.org/10.1002/mmce.22501>

[Link to publication on Research at Birmingham portal](#)

General rights

Unless a licence is specified above, all rights (including copyright and moral rights) in this document are retained by the authors and/or the copyright holders. The express permission of the copyright holder must be obtained for any use of this material other than for purposes permitted by law.

- Users may freely distribute the URL that is used to identify this publication.
- Users may download and/or print one copy of the publication from the University of Birmingham research portal for the purpose of private study or non-commercial research.
- User may use extracts from the document in line with the concept of 'fair dealing' under the Copyright, Designs and Patents Act 1988 (?)
- Users may not further distribute the material nor use it for the purposes of commercial gain.

Where a licence is displayed above, please note the terms and conditions of the licence govern your use of this document.

When citing, please reference the published version.

Take down policy

While the University of Birmingham exercises care and attention in making items available there are rare occasions when an item has been uploaded in error or has been deemed to be commercially or otherwise sensitive.

If you believe that this is the case for this document, please contact UBIRA@lists.bham.ac.uk providing details and we will remove access to the work immediately and investigate.

**RESEARCH ARTICLE**

Two-GHz hybrid coaxial bandpass filter fabricated by stereolithography 3-D printing

Milan Salek | Yi Wang | Michael J. Lancaster

Department of Electronic, Electrical and Systems Engineering, University of Birmingham, Birmingham, UK

Correspondence

Milan Salek, Department of Electronic, Electrical and Systems Engineering, University of Birmingham, Birmingham B15 2TT, UK.

Email: m.salek@bham.ac.uk

Funding information

Engineering and Physical Sciences Research Council, Grant/Award Number: EP/S013113/1

Abstract

This brief presents a fourth-order hybrid coaxial bandpass filter, which is fabricated using Stereolithography 3-D printing. The filter is designed to operate at a center frequency of 2 GHz, with a bandwidth of 40 MHz, a Chebyshev response and two symmetrical transmission zeros at 1.96 GHz and 2.04 GHz to achieve a better frequency selectivity. Usually in coaxial cavity filter design, the main-line couplings and cross couplings are realized using coupling irises or probes. However, in the filter presented here, the main-line couplings between coaxial resonators and input/output coupling are realized using Printed Circuit Board (PCB) lines instead. This novel idea allows different topologies to be designed easily by altering the PCB layout. It also allows multiple cross couplings to be included in the PCB layout for different filter topologies. In addition, the quality factor of each of the coaxial resonators in the filter is increased by introducing base rounding in the resonator. The filter was tested, and the measurement result of the filter shows very good agreement with simulated result without tuning, which indicates the accuracy of the fabrication process.

KEYWORDS

3-D printing, bandpass filter, coaxial resonator, Printed Circuit Board, Stereolithography

1 | INTRODUCTION

Coaxial bandpass filters are used in various communication systems to separate desired frequencies from unwanted frequencies. They have been used widely in communication satellites and earth stations, because of their low loss, high selectivity, high-power capability, compact size, low-manufacturing cost, and easy tuning.^{1,2}

In microwave bandpass filter design, transmission zeros are normally required on one or both side of the passband as they provide a higher skirt selectivity of the passband and strong attenuation at specific frequencies for

interference suppression. Transmission zeros can be realized using cross couplings between resonators and/or between the input and output ports of the filter.^{3,4}

Many cross-coupled coaxial cavity filters have been designed in the past and some reported in References 5-10; here cross couplings have also been used in the design in order to achieve a better frequency selectivity. Using the cross coupling has also been reported for coaxial filters with multimode cavities.¹¹ It is also reported in References 12 and 13, that transmission zeros can be realized using non-resonating nodes. However, this technique requires non-resonating structures, which may

This is an open access article under the terms of the Creative Commons Attribution License, which permits use, distribution and reproduction in any medium, provided the original work is properly cited.

© 2020 The Authors. *International Journal of RF and Microwave Computer-Aided Engineering* published by Wiley Periodicals LLC.

cause out of band spurious peaks.¹³ In all the filters mentioned above, the main-line couplings and cross couplings are realized using coupling irises and/or probes, by changing the position and dimension of resonators, or using non-resonating nodes. The filter presented here uses Printed Circuit Board (PCB) lines for main-line couplings and a capacitive gap for cross coupling. This novel idea allows multiple cross couplings to be included in the PCB layout if different topologies are going to be implemented. In this design, the input and output couplings are also realized using PCB lines. The unloaded quality factor of each of the resonators in the filter is also increased by introducing base rounding in the resonator.

The filter reported here is a fourth-order coaxial filter operating at 2 GHz, with a fractional bandwidth of 2%, which is fabricated using the Stereolithography apparatus (SLA) 3-D printing process. This article is part of a comprehensive study on 3-D printed microwave circuits, where we are using the fact that complex shapes can be made easily. This has enabled a number of new novel ideas (including the one here),^{14,15} as well as investigation into the frequency limits of 3-D printing.^{16,17} The design procedure of the filter is explained in Section 2, and fabrication details are provided in Section 3. Section 4 provides measured and simulated results along with relevant discussion.

2 | FILTER DESIGN

The hybrid coaxial bandpass filter is designed to have a center frequency of 2 GHz, a fractional bandwidth of 2% (bandwidth of 40 MHz), a return loss of 20 dB and two symmetrical transmission zeros at 1.96 and 2.04 GHz, which produce two attenuation lobes of 31 dB on the lower and upper sides of the passband. The filter is constructed with four-quarter wavelength long coaxial resonators operating in TEM mode and it is specified in terms of general Chebyshev bandpass response.

The filter is designed based on coupling matrix theory,¹⁸⁻²⁰ where a folded $N + 2$ coupling matrix was used. The folded $N + 2$ coupling matrix of the filter is calculated to be

$$\begin{bmatrix} 0 & 1.023 & 0 & 0 & 0 & 0 \\ 1.023 & 0 & 0.868 & 0 & -0.179 & 0 \\ 0 & 0.868 & 0 & 0.771 & 0 & 0 \\ 0 & 0 & 0.771 & 0 & 0.868 & 0 \\ 0 & -0.179 & 0 & 0.868 & 0 & 1.023 \\ 0 & 0 & 0 & 0 & 1.023 & 0 \end{bmatrix}. \quad (1)$$

The matrix above contains the normalized values of all couplings in the filter including the input/output

couplings. To synthesis physical dimensions of the filter, unnormalized nonzero coupling coefficients and external quality factors need to be calculated, which is done based on technique explained in Reference 18-20. Using Equation (1), the unnormalized nonzero coupling coefficients and the external quality factors of the filter are calculated as $M_{12} = M_{34} = 0.0174$, $M_{23} = 0.0154$, $M_{14} = -0.00358$ and $Q_e = Q_{e1} = Q_{e5} = 47.77$ which are used to find physical dimensions of the filter.

As mentioned previously, the unloaded quality factor of each resonator in the filter is increased by introducing base rounding in the resonator. Figure 1 shows the cross section of the coaxial resonator used in the filter, which is a quarter wavelength long. As illustrated in Figure 1, the maximum current is flowing at the bottom of the resonator, which contributes a large part of the ohmic losses, so spreading the current with base rounding reduces the losses. Such a technique to increase unloaded quality factor has already been reported in References 21 and 22 but not widely used. It is also reported in References 21 and 22, that the optimal unloaded quality factor for a coaxial resonator can be obtained by making the ratio of inner diameter of outer conductor (b) to outer diameter of inner conductor (a) as $b/a = 3.59$. However, for the filter presented here, the ratio b/a is kept at 3 ($b = 30$ and $a = 10$ as it is denoted in Figure 1). Although this may not give the largest unloaded Q , this has no consequence here, as the main novelty of the article is the use of the PCB. However, it is still interesting to consider base rounding, and by adjusting the radius of the base R_b (as it is denoted in Figure 1) in the simulator CST

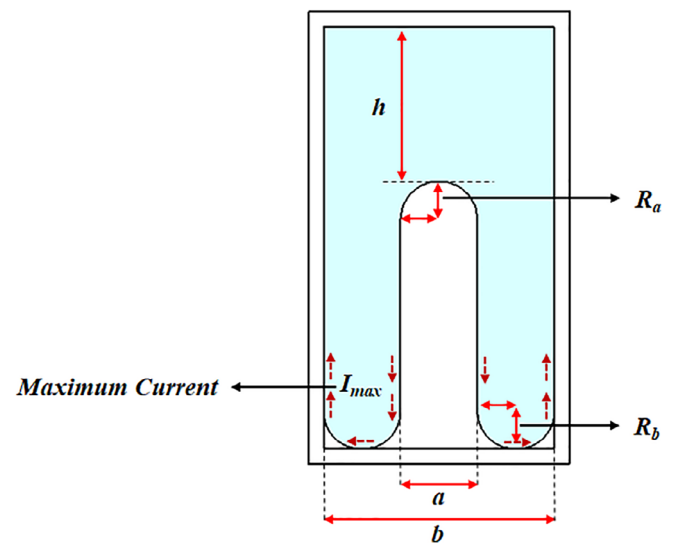

FIGURE 1 Cross section of the coaxial resonator with base rounding. Here, the outer diameter of the inner conductor a is 10 mm, the inner diameter of the outer conductor b is 30 mm and the open-end capacitive gap of the resonator h is 20 mm

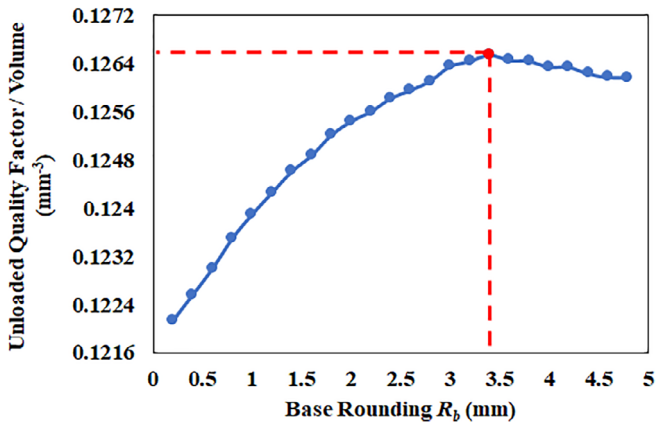
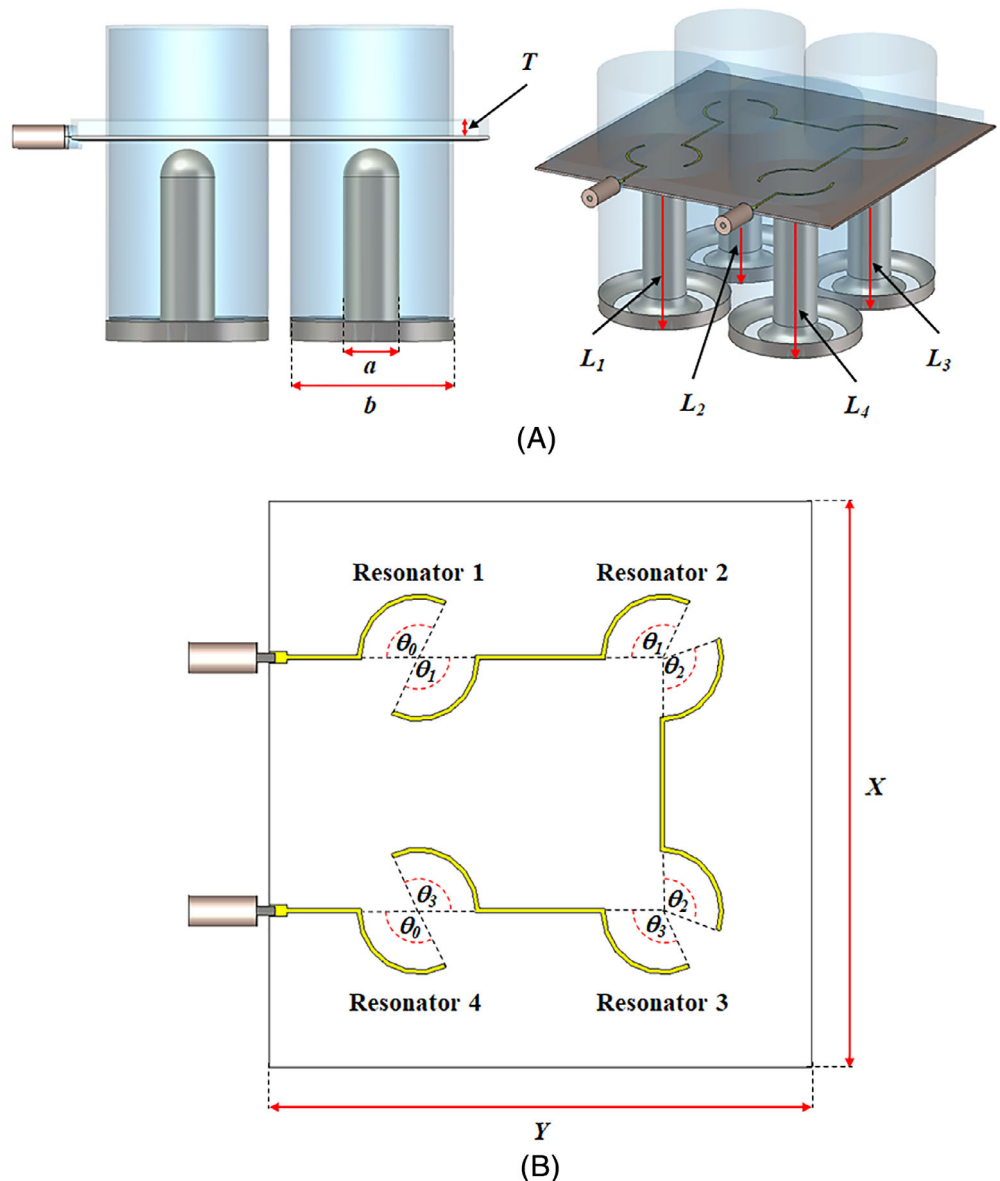

FIGURE 2 Relation between unloaded quality factor per volume and radius of the base rounding R_b , considering $b/a = 3$

Microwave Studio,²³ a relation between unloaded quality factor per volume and radius of base rounding R_b can be found. This is shown in Figure 2. Using the relation in Figure 2, the optimal radius of base rounding is found to be $R_b = 3.4$ mm for maximum unloaded quality factor per volume of 0.1265, which is denoted by a red dot in Figure 2. Here, the unloaded quality factor of the resonator is 4926 for the optimal radius of base rounding ($R_b = 3.4$ mm). The small rounding R_a , at the top of the inner conductor of the resonator is also introduced to improve power handling, as reported in References 21 and 22.

The next step of the design is to find physical dimensions of the filter based on the calculated unnormalized coupling coefficients and external Q values. Figure 3A shows the internal structure of the filter and Figure 3B

FIGURE 3 Internal structure of the 2 GHz hybrid coaxial bandpass filter. A, Internal structure of the filter, showing internal dimensions. The dimensions in millimeters are $a = 10$, $b = 30$, $T = 3$, $L_1 = L_4 = 28.539$ and $L_2 = L_3 = 28.623$. B, PCB layout of the filter, showing dimensions of PCB. The dimensions of the PCB in millimeters and the angle of PCB lines in degrees are $X = 76$, $Y = 75.6$, $\theta_0 = 116.6^\circ$, $\theta_1 = \theta_3 = 116.4^\circ$, and $\theta_2 = 108.3^\circ$



shows the PCB layout for the filter couplings. Here, the main-line couplings are realized using PCB lines, the cross coupling is realized using a capacitive gap (to the box lid), and the input/output couplings are realized with the use of PCB lines attached to subminiature version A (SMA) connectors. The PCB is placed 0.9 mm above the inner conductor of the coaxial resonators. It should be noted that the PCB does not have a ground plane. Referring to Figure 3B, the input/output PCB lines are connected to SMA connectors through wider PCB lines, having a width of 1.565 mm and a length of 2.5 mm, which has a characteristic impedance of $Z_0 = 50 \Omega$. The rest of the PCB lines have a width of 0.6 mm. Note that the ground for these lines is the copper on the 3-D printed structure. The only place a planar ground does not exist is inside the coaxial cavities. The PCB used in the design was RT/Duroid 5880, which has a dielectric constant of 2.2, a dielectric thickness of 508 μm , a dielectric loss tangent of 0.0009 and copper thickness of 18 μm .²⁴

The coupling between resonators 1 and 2, and resonators 3 and 4 are realized by adjusting the angle of the PCB lines that are denoted by $\theta_1 = \theta_3$ in Figure 3B. They are set by coupling coefficients $M_{12} = M_{34}$. Similarly, the coupling between resonators 2 and 3 is realized by adjusting the angle of the PCB line that is denoted by θ_2 and set by the coupling coefficient M_{23} . The cross coupling between resonators 1 and 4 is realized by adjusting the capacitive gap to the lid and denoted by T in Figure 3A. This is set by coupling coefficient M_{14} . The input/output coupling is realized by adjusting the angle of PCB line denoted by θ_0 in Figure 3B, which is set by external quality factors Q_e .

Figure 4 shows the external design of the filter, along with all external dimensions in millimeters. As it can be seen, the filter consists of three parts; the bottom part, the PCB, and the top part, which is bolted to the bottom part with the PCB in between. Simulations and final optimization of the filter are performed using CST Microwave Studio,²³ and are shown together with the measured results, in Section 4. The optimized values of the dimensions are provided in the figure captions in Section 2.

3 | FABRICATION PROCESS

The filter reported in this brief was fabricated using Stereolithography apparatus (SLA), and the PCB was fabricated separately using conventional PCB manufacturing technique. The filter was fabricated layer by layer, where each layer was built by scanning an ultraviolet laser beam across the surface of a nonconductive photocurable

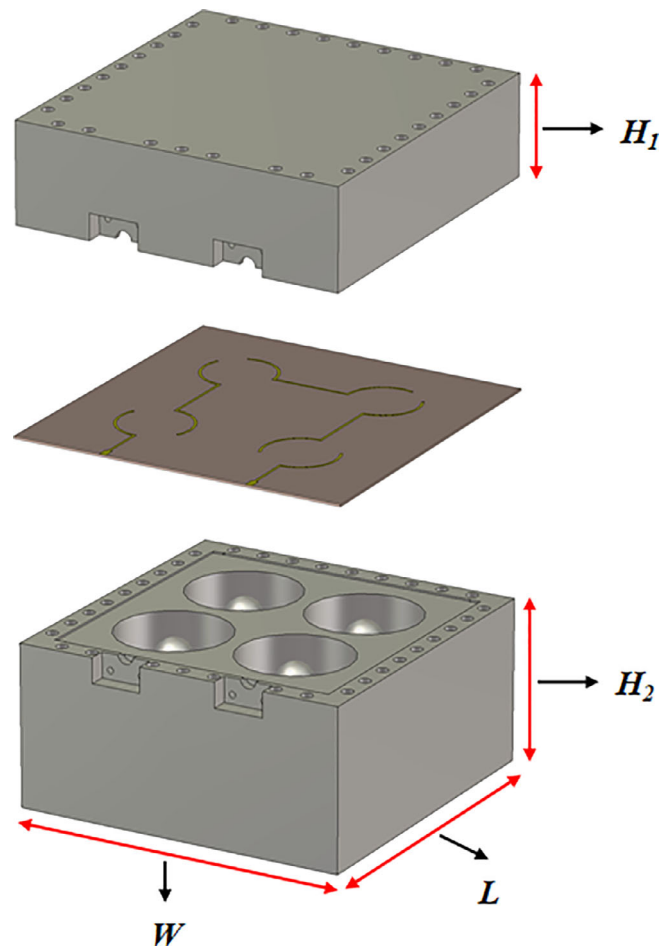

FIGURE 4 External design of the 2 GHz hybrid coaxial bandpass filter, showing external dimensions. The dimensions in millimeters are $H_1 = 25.612$, $H_2 = 41.697$, $L = 88.28$, and $W = 88.28$

polymer resin. In this case the resin was Accura Xtreme white 200 resin. The printing resolution in the SLA process was 0.1 mm. After printing, the filter was subsequently electroless plated with 20 μm thick copper; this copper layer was compensated in the 3-D model of the filter prior to printing process. In the process of 3-D printing, supporting material was used, which was only on the outer base of the parts. The supporting material was built from the same material, used to build the parts and was removed during post processing.

Figure 5A shows a photograph of the fabricated filter after being copper plated and assembled, here the PCB is placed between the top and bottom parts. Figure 5B shows the PCB on top of the bottom part, with both SMA connectors soldered to the PCB. Figure 5C shows the top and bottom parts of the filter individually, and Figure 5D shows the PCB before being soldered to the SMA connectors. The top and bottom parts of the filter with the PCB in between are assembled using 34 nuts and bolts. Both SMA connectors are straight 50 Ω female flange mount

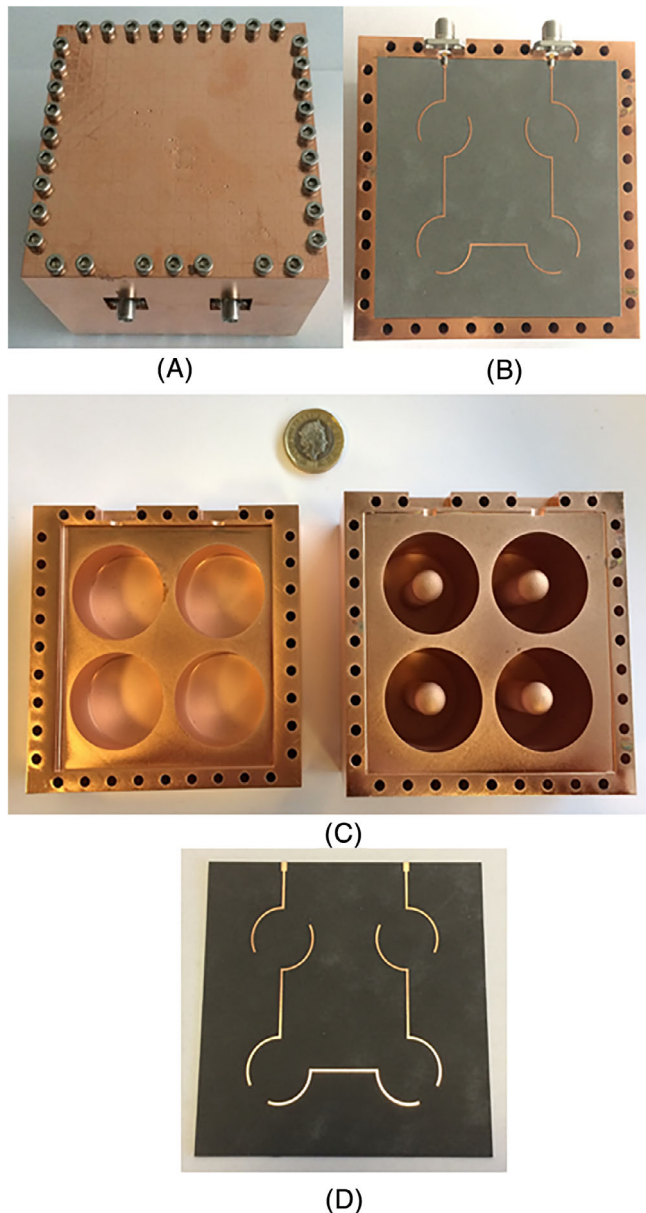
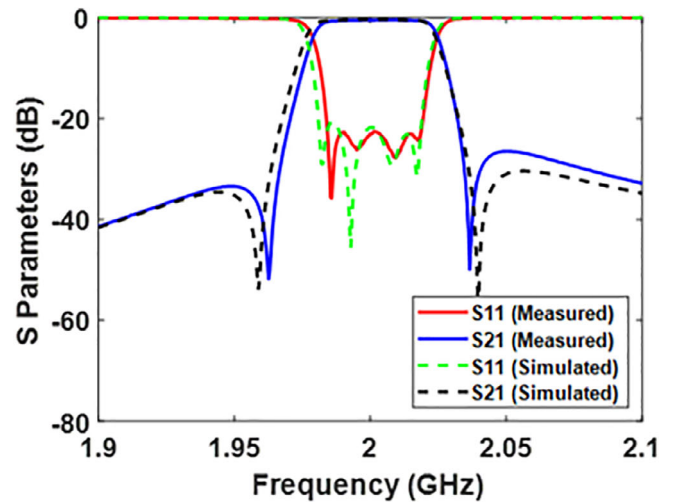

FIGURE 5 Photograph of the fabricated 2 GHz hybrid coaxial bandpass filter after being copper plated. A, Fabricated filter with all parts assembled together. B, Position of the PCB, which is sitting on the bottom part. C, Top and bottom parts of the filter. D, Fabricated PCB

SMA connectors with a solderable termination. Both connectors are soldered to the PCB and bolted onto the filter walls.

4 | MEASUREMENT AND DISCUSSION

The S -parameter measurements of the filter were performed on Agilent E8362C PNA network analyzer.



(A)

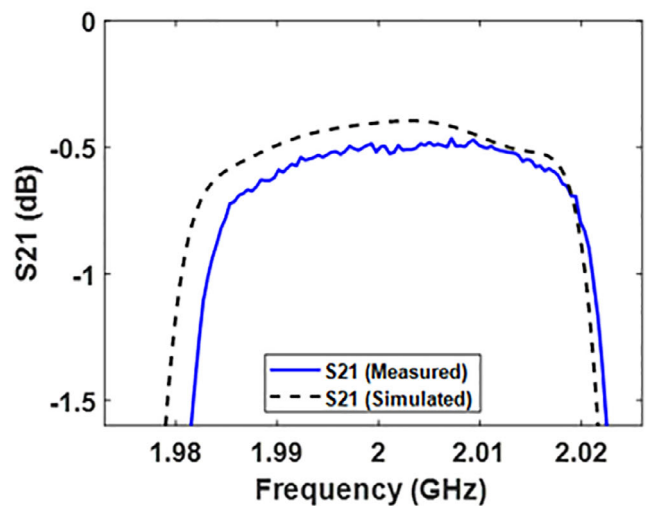

(B)

FIGURE 6 Measured and simulated results of the 2 GHz hybrid coaxial bandpass filter. A, Measured and simulated results over the frequency range of 1.9 to 2.1 GHz. B, Expanded view of S_{21} over the passband

Figure 6 shows the measured and simulated results of the hybrid coaxial bandpass filter, where the measured results are denoted with solid lines and simulated results with dashed lines.

The results in Figure 6A show that the measured center frequency is shifted up slightly by 2 MHz (0.1% of the simulated center frequency) and the minimum return loss is about 22.5 dB. The small frequency shift is believed to be caused by dimensional inaccuracies during the manufacturing process. The frequency shift can be corrected by remanufacturing the filter. However, in this case the frequency shift is very small.

Looking at the expanded view of S_{21} in Figure 6B, it can be observed a minimum insertion loss of around

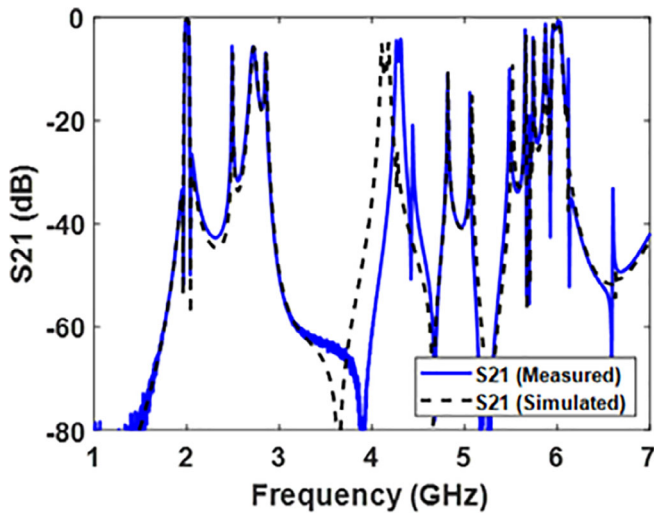

FIGURE 7 Measured and simulated S_{21} over a wide frequency range

0.465 dB over the passband, which is only 0.048 dB higher than the simulated results. The typical surface roughness of these SLA structures is generally about $1 \mu\text{m}$.²⁵ This reduces the effective conductivity of copper to $3.17 \times 10^7 \text{ S/m}$. According to calculation in CST,²³ this results in an additional loss of 0.046 dB. However, this loss is already reflected in the simulated results. A return loss of 20 dB contributes about 0.044 dB to the insertion loss, which is also taken into account as with the loss in the PCB tracks. The simulated and measured insertion losses are very close, and the small additional difference is believed to be caused by a combination of factors, which include contamination of copper surface, impurities in the copper, losses in connectors, different surface roughness, and loss at the interface between the box joints. The minimum insertion loss of 0.465 dB corresponds to an unloaded quality factor of 2106 from the measured result and 2359 from the simulated result. Here, the unloaded factors are estimated based on the technique explained in Reference 26.

Figure 7 shows the frequency response of the filter over a wide frequency range. Generally, coaxial filters

have good spurious free performance compared to other type of filters.¹⁴ However, the coaxial filter presented here has a slightly degraded spurious free performance. This is because the PCB lines act as spurious resonators. The length of PCB lines that couple resonators 1 and 2, and resonators 3 and 4 is about 51 mm, the length of PCB line that couples resonators 2 and 3 is about 48 mm, and the length of PCB lines that couple the first and last resonators to the source and load is about 26 mm. By assuming that the PCB lines act as half wavelength resonators in free space, their resonance frequencies can be estimated.

The resonance frequency of the PCB lines that couple resonators 1 and 2, and resonators 3 and 4 is estimated as 2.9 GHz, the resonance frequency of the PCB line that couples resonators 2 and 3 is estimated as 3 GHz, and the resonance frequency of the PCB lines that couple first and last resonators to the source and load is estimated as 5.6 GHz. By looking at Figure 7, based on these estimations, the length of PCB lines is probably the main cause of the spurious performance of the filter. The spurious free performance of the filter can be improved by redesigning the length of PCB lines shorter, which can be done by reducing the wall thickness between resonators.

Table 1 provides a comparison of measured performance of the proposed filter with other filters that are fabricated using SLA 3-D printing technique. Although the filters in Table 1 have different specifications and resonator types, the reported filter has a comparable performance in terms of insertion loss, return loss and frequency shift.

5 | CONCLUSION

This brief presented a hybrid coaxial bandpass filter with two transmission zeros, where the main-line couplings and the input/output coupling are realized using PCB lines, and the cross coupling is realized using a capacitive gap. The novel idea of using PCB lines to achieve the couplings instead of using coupling irises or probes allows more flexibility and variation in the design topologies.

TABLE 1 Comparison of the proposed filter with other SLA 3-D printed filters

Reference	Center frequency (GHz)	Fractional bandwidth	Insertion loss (dB)	Return loss (dB)	Resonator type	Frequency shift
¹⁴	3.019	3.38%	0.7	>13.5	Coaxial	0.63%
²⁷	10	3%	0.25	>18	Spherical	<0.01%
²⁸	32	1%	0.56 ~ 0.7	>17	Hemi spherical	0.04%
²⁹	10	5%	0.107	>20	Spherical	0.05%
This work	2.002	~2%	0.465	>22.5	Coaxial	0.1%

The filter was fabricated using SLA 3-D printing process, and good agreement between the measured and simulated results demonstrated the accuracy of the fabrication process.

ORCID

Milan Salek  <https://orcid.org/0000-0003-4376-6869>

REFERENCES

- Mansour R. Filter technologies for wireless base stations. *IEEE Microw Mag*. 2004;5(1):68-74.
- Kudisia C, Cameron R, Tang W-C. Innovations in microwave filters and multiplexing networks for communications satellite systems. *IEEE Trans Microw Theory Tech*. 1992;40(6):1133-1149.
- Cameron RJ. General coupling matrix synthesis methods for Chebyshev filtering functions. *IEEE Trans Microw Theory Tech*. 1999;47(4):433-442.
- Thomas JB. Cross-coupling in coaxial cavity filters—a tutorial overview. *IEEE Trans Microw Theory Tech*. 2003;51(4):1368-1376.
- Wang Y, Yu M. True inline cross-coupled coaxial cavity filters. *IEEE Trans Microw Theory Tech*. 2009;57(12):2958-2965.
- Hoft M, Yousif F. Orthogonal coaxial cavity filters with distributed cross-coupling. *IEEE Microw Wireless Compon Lett*. 2011;21(10):519-521.
- Yuceer M. A reconfigurable microwave combline filter. *IEEE Trans Circuits Syst II Exp Briefs*. 2016;63(1):84-88.
- Zhan J, Chen X, Gong L. A realization of convenient structure with electrical coupling in coaxial cavity. *IET Int Radar Conf 2013 Xian China*. 2013;1-4.
- Hoft M. Tunable capacitive coupling for cavity resonator filters. Paper presented at: 2009 German Microwave Conference Munich Germany. 2009:1-4.
- Dad V. K, Gupta S. Novel high Q coaxial resonator filter for millimeter wave application. Paper presented at: 2017 IEEE MTT-S International Microwave RF Conference (IMARC) Ahmedabad India. 2017:1-4.
- Wang X, Jang G, Lee B, Park N. Compact quad-mode bandpass filter using modified coaxial cavity resonator with improved Q-factor. *IEEE Trans Microw Theory Tech*. 2015;63(3):965-975.
- Amari S, Macchiarella G. Synthesis of inline filters with arbitrarily placed attenuation poles by using nonresonating nodes. *IEEE Trans Microw Theory Tech*. 2005;53(10):3075-3081.
- Cogollos S, Cameron R. J, Mansour R. R, Yu M, Boria V.E. Synthesis and design procedure for high performance waveguide filters based on nonresonating nodes. Paper presented at: 2007 IEEE MTT-S International Microwave Symposium Honolulu HI. 2007:1297-1300.
- Salek M, Shang X, Lancaster MJ. Compact S-band coaxial cavity resonator filter fabricated by 3-D printing. *IEEE Microw Wireless Compon Lett*. 2019;29(6):382-384.
- Zhang F, Gao S, Li J, et al. 3-D printed slotted spherical resonator bandpass filters with spurious suppression. *IEEE Access*. 2019;7:128026-128034.
- Salek M, Shang X, Lancaster M. J, Roberts R. C, Starke T, Boettcher F, Weber D. 90 GHz micro laser sintered filter: reproducibility and quality assessment. Paper presented at: 2019 49th European Microwave Conference (EuMC) Paris France. 2019:296-299.
- Salek M, Shang X, Roberts RC, et al. W-band waveguide bandpass filters fabricated by micro laser sintering. *IEEE Trans Circuits Syst II Exp Briefs*. 2019;66(1):61-65.
- Cameron RJ, Kudisia CM, Mansour RR. *Microwave Filters for Communication Systems: Fundamentals, Design, and Applications*. Hoboken, NJ: John Wiley & Sons; 2018.
- Hong J. *Microstrip Filters for RF/Microwave Applications*. Hoboken, NJ: John Wiley & Sons; 2011.
- Hong J, Lancaster MJ. Couplings of Microstrip Square open-loop resonators for cross-coupled planar microwave filters. *IEEE Trans Microw Theory Tech*. 1996;44(11):2099-2109.
- Höft M, Burger S. Q-factor improvement of combline resonators. Paper presented at: German Microwave Conference 2005 Ulm Germany. 2005:53-56.
- Hoft M, Magath T, Bartz O, Burger S. Corner rounding for increased quality factor of cavity resonators. Paper presented at: 2005 Asia-Pacific Microwave Conference Proceedings Suzhou China. 2005:1-4.
- Computer Simulated Technology (CST). *Microwave Studio 2019*. <http://www.cst.com/>.
- Rogers Corporation. <https://www.rogerscorp.com/>. Accessed June 15, 2018.
- Shang X, Penchev P, Guo C, et al. W-band waveguide filters fabricated by laser micromachining and 3-D printing. *IEEE Trans Microw Theory Tech*. 2016;64(8):2572-2580.
- Cohn S. Dissipation loss in multiple-coupled-resonator filters. *Proc IRE*. 1959;47(8):1342-1348.
- Guo C, Shang X, Li J, Zhang F, Lancaster MJ, Xu J. A lightweight 3-D printed X-band bandpass filter based on spherical dual-mode resonators. *IEEE Microw Wireless Compon Lett*. 2016;26(8):568-570.
- Li J, Guo C, Mao L, Xu J. Compact high-Q hemispherical resonators for 3-D printed bandpass filter applications. Paper presented at: 2017 IEEE MTT-S International Microwave Symposium Honolulu HI 2017:1591-1594.
- Guo C, Shang X, Lancaster MJ, Xu J. A 3-D printed lightweight X-band waveguide filter based on spherical resonators. *IEEE Microw Wireless Compon Lett*. 2015;25(7):442-444.

AUTHOR BIOGRAPHIES

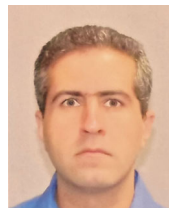

Milan Salek received the B.Eng degree in Electrical and Electronic Engineering from the Aston University, Birmingham, UK, in 2016, and the PhD degree in Microwave Engineering from the University of Birmingham, Birmingham, UK, in 2019. Presently he is a Research Fellow in the Department of Electronic, Electrical and Systems Engineering, University of Birmingham. His current research interests include 3-D printed passive microwave devices, bolometric and diode-based power sensors, as well as millimeter-wave and terahertz circuits.

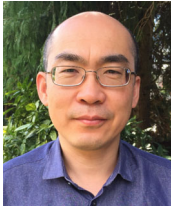

Yi Wang (M'09-SM'12) was born in Shandong, China. He received the B.Sc. degree in physics and M.Sc. degree in condensed matter physics from the University of Science and Technology, Beijing, China, in 1998 and 2001, respectively, and the PhD degree in electronic and electrical engineering from the University of Birmingham, Edgbaston, Birmingham, UK, in 2005. In 2011, he became a Senior Lecturer and then Reader at the University of Greenwich. In 2018, Yi joined Birmingham as a Senior Lecturer. His current research interests include millimeter-wave and terahertz devices for metrology, communications and sensors, micromachining, microwave circuits based on multiport filtering networks, and filter-antenna integration.



Michael J. Lancaster was born in England in 1958. He was educated at Bath University, UK, where he graduated with a degree in Physics in 1980, followed by a PhD in 1984 for research into nonlinear underwater acoustics. After leaving Bath

University he joined the surface acoustic wave (SAW) group at the Department of Engineering Science at Oxford University as a Research Fellow. The research was in the design of new, novel SAW devices, including RF filters and filter banks. In 1987, he became a Lecturer at The University of Birmingham in the Department of Electronic and Electrical Engineering, lecturing in electromagnetic theory and microwave engineering. Shortly after he joined the department he began the study of the science and applications of high temperature superconductors, working mainly at microwave frequencies. His present personal research interests include microwave filters and antennas, as well as the high frequency properties and applications of a number of novel and diverse materials.

How to cite this article: Salek M, Wang Y, J. Lancaster M. Two-GHz hybrid coaxial bandpass filter fabricated by stereolithography 3-D printing. *Int J RF Microw Comput Aided Eng.* 2020;e22501. <https://doi.org/10.1002/mmce.22501>